

# xylem

## Rental Guide

Rental solutions  
for your pumping  
or treatment  
challenges

0845 707 8012

24/7 Rapid Response



## Welcome to our Rental Guide

Xylem is a force to be reckoned with when providing total solutions for fluid handling and control. With a history spanning 100 years, it is a company passionate about innovation and determined to solve the most challenging water issues. Xylem's powerful combination of products, services and applications expertise serves market sectors including Public Utilities, Infrastructure, Municipal, Building Services and Industry.

Our Rental division, specialises in the rental of Flygt electric submersible pumps, Godwin prime assisted diesel pumps, Wedeco and Sanitaire treatment systems. Xylem remain unique in the market place supporting rental applications with the products that Xylem also manufacture as Original Equipment Manufacturers of each of the famous brands included in the range. Our skilled team of engineers offer unprecedented technical backup and design of bespoke pumping and treatment systems, whether temporary or semi-permanent, for anything from a small amount of nuisance water to the movement of sewage and major flow diversion schemes.

By choosing Xylem for your rental requirements, you gain automatic access to a wealth of experience and technical knowledge. Our engineers can assess your needs, design your pumping or treatment system and install it. Offering a 24/7 rapid response service, with fully owned transportation including lifting cranes and strategically located regional depots throughout the UK and Ireland, you can be confident in our ability to react quickly to your rental needs.

## Contents

4	General Guide to Pump Selection
5	Guide to Performance Data
6	Pumping Definitions
7 - 12	2000/BS Series - Drainers
13 - 18	2600 Range - Drainers
19 - 22	2800 Range - Drainers
23	Flygt 2000 Series Electrical Information
24 - 27	Flygt Bibo Alpha
28 - 31	Flygt Concertor™
32 - 38	3000/N Series - Sewage
39 - 40	N Type Chopper Pumps
42 - 51	Great and Grey - Sewage
52	Channel Impeller Pump - Wastewater
53	Flygt 3000 Series Electrical Information
54 - 55	Flygt Dri-Prime Add On
56	Lowara Clean Water Booster Sets
57	Monitoring & Control
58	Rental Ultrasonic Controller Specification
59	Electrical Equipment
60 - 62	Soft Starter Panels - Specification
63 - 67	VFD Starter Panel - Specification
68 - 69	Godwin
70 - 71	Godwin CD series
72 - 73	Godwin NC series
74	Water Treatment
75	Dissolved Air Flotation
76 - 77	Taron Activated Sludge Filter
78 - 79	Wedeco UV Water Treatment
80 - 83	Mixers
84 - 85	Aeration - Radial Aerators
86	Radial Aerators - Oxygen Transfer Rate
87	Aeration - Flyjet
88	Pump Flotation Modules
89 - 90	Hoses and Fittings
91	Friction Loss in Pipe Fittings Chart
92 - 93	Weight Reference Guide
94 - 95	Conversion Factors
96	Flange Sizes
97	Contact Us

The Information contained within this document is for guidance only and is accurate to the best of our knowledge at time of going to print.

# General Guide to Pump Selection

## Items to check:

**The electrical supply available** – What voltage, single or 3 phase and the maximum amperage. If the power supply is inadequate, please ask for details of generators or consider using a Godwin prime assisted diesel pump.

**Total head requirement** – The most important calculation to get right! It is the sum of the total static head (the vertical distance from the suction strainer to the point of discharge) plus any friction loss allowances. When sizing a pump, the critical thing to determine is the total generated head (TGH) requirement.

### Calculation

**Static suction** (strainer to the pump) + **static delivery** (from pump to the point of discharge) + **friction loss** (resistance incurred by liquid when flowing through hoses) = **total generated head**.

## Dirty Water or Solids Handling?

Use drainer submersibles (BS Series) and general purpose diesels for dirty water pumping and where particles are relatively small e.g. sand and gravel.

Use sewage submersibles (N Series) and solids handling diesels for sewage pumping and where particles are larger e.g. stones and debris.

# Guide to Performance Data

The following curves are QH charts showing the performance of the hydraulic unit at constant shaft speeds. Q is represented as litres per second, and total head, H, is in metres.

The data represented in this section is for your guidance only. Detailed information can be obtained from your local Xylem sales engineer.

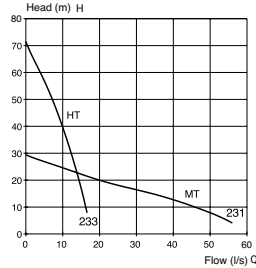

## BS Pumps

The curve is the specified performance of the impeller selected. The values shown are for a BS 2125 pump. Impeller characteristics are coded as follows: LT=Low head. MT=Medium head. HT=High head. SH=Super high head.

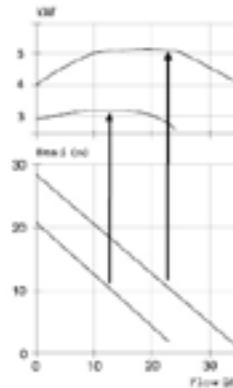

## N Pumps

The power consumption is shown on the chart. The power consumption values for two selected performance duty points are shown by plotted straight lines from the lower to the upper chart. The lower chart and corresponding table provide performance data for different impellers used in a high head 3102 pump. Additional charts for LT, MT and SH models are shown for each respective pump type.

Impeller Code	No. of vanes	Outlet dia. mm NP vers	Through let, mm	Motor rating, kW	rpm	Available versions
252	1	80	Ø52	4.4	2850	NP/NS
254	1	80	Ø46	4.4	2850	NP/NS

## Pumping Definitions

Pumping is the addition of energy to a fluid, which is used mainly for the purpose of moving the fluid from one point to another.

### Centrifugal pumps

One which transfers energy to the liquid by means of an impeller; i.e. "A rotating device equipped with suitable vanes". (The liquid is therefore delivered in a continuous and uninterrupted flow).

### Positive displacement pumps

One which transfers energy to a liquid by means of a reciprocating piston, or similar device, giving an intermittent or "pulsed flow".

### Ejector or jet pumps

By mixing a high speed drive medium with a low velocity pumped medium, an energy exchange is achieved converting velocity energy into pressure, giving a continuous flow.

Q= capacity or volume

H= total head

Total head= static head + friction loss head.

### Static head

The head against which the pump must work when the liquid is stationary.

### Friction loss head

The head generated by friction of moving liquid, against the walls of the discharge pipes.

### Net positive suction head (npsH)

Energy from an outside source i.e. static head or atmosphere pressure required to ensure liquid enters the pump volute.

### Cavitation

Cavitation occurs when there is insufficient n.p.s.h. i.e., too low a suction pressure induces cavitation. This causes erosion to the metal surfaces due to the vapour bubble collapsing, allowing the liquid to rush into the subsequent spaces at high velocity, thus creating a water hammer effect.

## Flygt 2000 Series Dewatering Pumps

### Introduction

Flygt type BS - Pumps are suitable for a very broad field of application. They are used for dewatering on construction sites for houses, streets and roads, tunnels and rock caverns, harbours and dams, for drainage and ballast pumping in shipyards, for drainage in the event of flooding in mines and industrial plants, for cooling, clean water and raw water supply, water spraying, etc.

The type BS - Pump is of transportable design and requires no installation. All you need to do is to lower it into water and start it. There is a type BS pump suitable for all applications - be it for high capacities, high heads, confined spaces or explosive environments.

The type BS - Impeller is an open or semi-open channel impeller, made of abrasion resistant high chromium steel and designed specifically for handling media containing highly abrasive materials, such as clay, sand and drilling fines etc.



## Flygt 2000 Series Dewatering Pumps

Can be installed in a variety of applications



The type BS - Pump can stand directly on the sump floor



or can be suspended from a rope or chain



The compact design enables type BS - Pumps to be used in confined spaces - A 200mm diameter pipe is sufficient for the slimmest pump



The head generated can be increased by connecting two or more type BS - Pumps in series

## Flygt 2000 Series Dewatering Pump Dimensions

Pump type	A (mm)	B (mm)	Strainer Opening (mm)
<b>BS2125</b>			
MT	710	485/515/535	6x50
HT	710	465/390	6x50
<b>BS2151</b>			
LT	745	640/655	10x42
MT	745	640/655	10x42
HT	745	570/590	10x42
<b>BS2201</b>			
Cast Iron			
MT	1200	620	15x45
HT	1050	430	10x10
Aluminium			
MT	1253	500	15x45
HT	1050	430	10x10
<b>BS2250</b>			
MT	1144	885/912	15x45
HT	1144	830	15x45
<b>BS2400</b>			
MT	1250	780	10x10
HT	1250	680	10x10
<b>BS2610</b>	570	230	7 x 16
<b>BS2620</b>	620	275	7 x 16
<b>BS2640</b>			
MT	760	375	8 x 18
HT	760	342	8 x 18
<b>BS2660</b>			
MT	832	430	9 x 18
HT	832	430	9 x 18
<b>BS2670</b>			
MT	955	500	10 x 20
HT	955	480	10 x 20
<b>BS2840</b>			
MT	762	592	10mm Dia
HT	762	553	10mm Dia
<b>BS2860</b>			
MT	889	668	10mm Dia
HT	889	646	10mm Dia
<b>BS2870</b>			
MT	991	740	12mm Dia
HT	991	719	12mm Dia

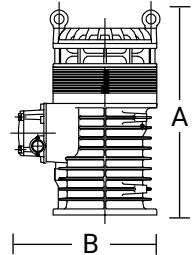
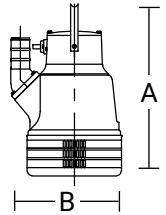

## Flygt BS 2125 and BS 2151

### BS 2125 MT & HT

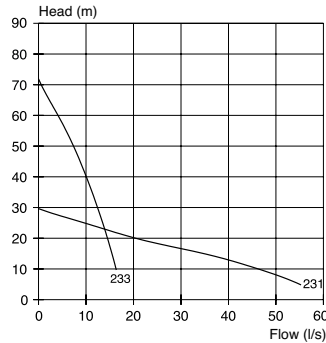

Motor: MT: 8.0kW, 2800rpm  
 Max. power input: 9.5kW  
 Weight: MT 83kg, HT 92kg

Dimensions:  
 Max. height: 710mm  
 Max. width: MT 485/515/535mm, HT 465mm  
 Hose size: HT 75mm, MT 150mm

### BS 2151 MT & HT

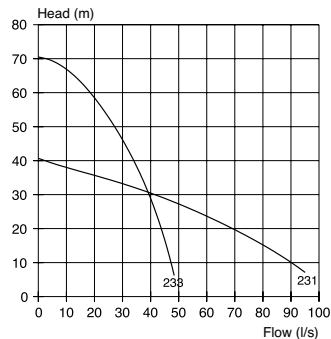

Motor: 20kW, 2900rpm  
 Max. power input: 23kW  
 Weight: 165kg

Dimensions:  
 Max. height: 745mm  
 Max. width: MT 640/655mm, HT 570/590mm  
 Hose size: HT 100mm, MT 150mm

## Flygt BS 2201

### BS 2201 LT

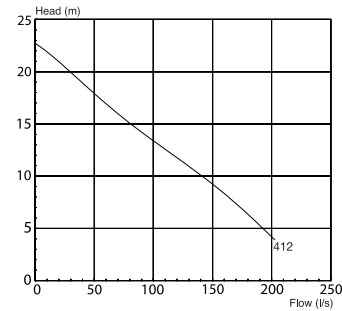

Motor: 37kW, 1465rpm  
 Max. power input: 41kW  
 Weight: 280kg

Dimensions:  
 Max. height: 1330mm  
 Max. width: 500mm  
 Hose size: 200mm

### BS 2201 MT & HT

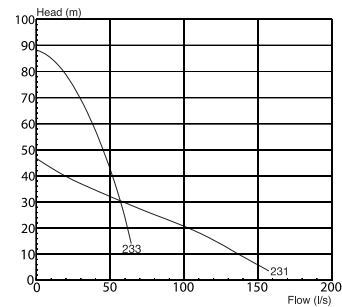

Motor: 37kW, 2920rpm  
 Max. power input: 41kW  
 Weight: 280kg

Dimensions:  
 Max. height: 1330mm  
 Max. width: 500mm  
 Hose size: MT 200mm, HT 100mm

## Flygt BS 2250 and BS 2400

### BS 2250 MT & HT

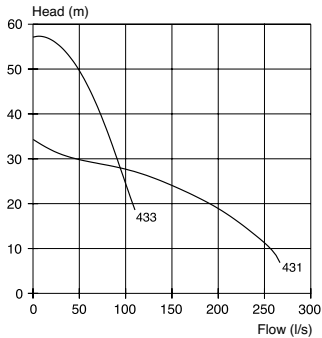

Motor: 54kW, 1470rpm  
Max. power input: 58kW  
Weight: 540kg

Dimensions:  
Max. height: 1100mm  
Max. width: 950mm  
Hose size: HT 150mm, MT 200mm, MT 250mm

### BS 2400 MT & HT

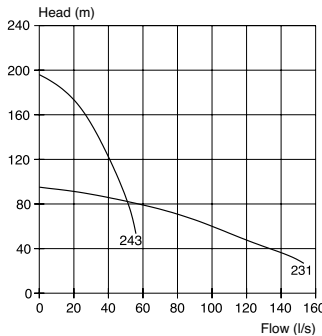

Motor: 90kW, 2970rpm  
Max. power input: 97kW  
Over temperature protection  
in stator windings  
Weight: MT 900kg, HT 985kg

Dimensions:  
Max. height: MT 1250mm, HT 1251mm  
Max. width: MT 778mm, HT 680mm  
Hose size: HT 100mm, MT 150mm

## Flygt 2600 Range



### Introduction

Clearing your worksite of unwanted water is critical to productivity. Flooding means time delays, cost overruns and unsafe working conditions. To get to the bottom of any dewatering job, you can rely on Flygt 2600 pumps.

Undertaking tough dewatering jobs is what the Flygt 2600 series does best. It ensures that you can get on with the work at hand safely and reliably. All this, thanks to extreme portability, automatic operation, easy maintenance, lasting performance.

The Flygt 2600 series is built to last. Radically engineered from the ground up, these robust dewatering pumps feature innovative hydraulics, durable materials and a practical, ergonomic design. The result is unmatched wear resistance, consistent performance over time.

Flygt 2600 pumps cover low, medium, high and super-high pressures to handle most any application for worksites of every size.

## Flygt BS 2610

### BS 2610 MT 110V Single Phase

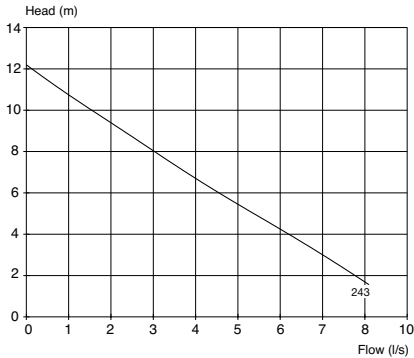

Rated power: 0.85kW  
Weight: 21kg



Dimensions:  
Max. height: 570mm  
Max. width: 230mm  
Discharge: Ø - 2"  
Strainer hole: 7x16mm

### BS 2610 MT 400V 3 Phase

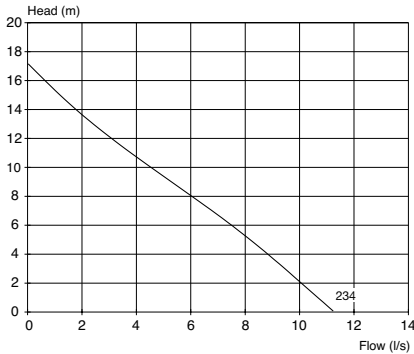

Rated power: 1.2kW  
Weight: 21kg



Dimensions:  
Max. height: 570mm  
Max. width: 230mm  
Discharge: Ø - 2"  
Strainer hole: 7x16mm

## Flygt BS 2620 and BS 2640

### BS 2620 MT

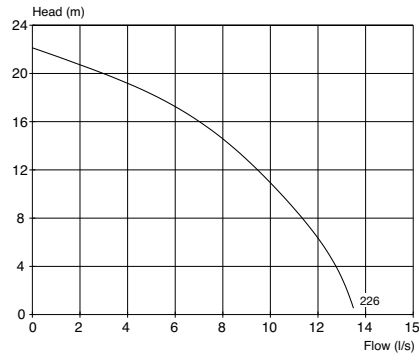

Rated power: 2.2kW  
Weight: 32kg



Dimensions:  
Max. height: 620mm  
Max. width: 275mm  
Discharge: Ø - 3"  
Strainer hole: 7x16mm

### BS 2640 MT

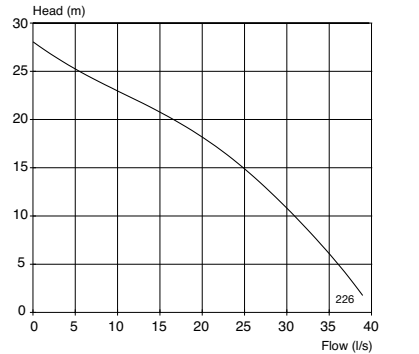

Rated power: 5.6kW  
Weight: 51kg



Dimensions:  
Max. height: 760mm  
Max. width: 375mm  
Discharge: Ø - 4"  
Strainer hole: 8x18mm

## Flygt BS 2640 and BS 2660

### BS 2640 HT

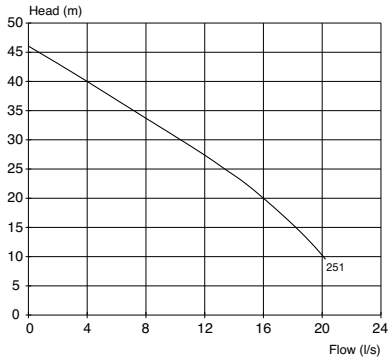

Rated power: 5.6kW  
Weight: 51kg



Dimensions:  
Max. height: 760mm  
Max. width: 342mm  
Discharge: Ø - 3"  
Strainer hole: 8x18mm

## Flygt BS 2660 and BS 2670

### BS 2660 HT

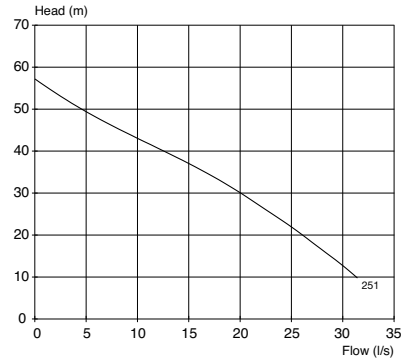

Rated power: 10kW  
Weight: 78kg



Dimensions:  
Max. height: 832mm  
Max. width: 430mm  
Discharge: Ø - 4"  
Strainer hole: 9x18mm

### BS 2660 MT

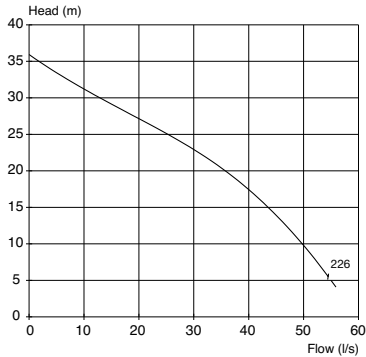

Rated power: 10kW  
Weight: 78kg



Dimensions:  
Max. height: 832mm  
Max. width: 430mm  
Discharge: Ø - 6"  
Strainer hole: 9x18mm

### BS 2670 MT

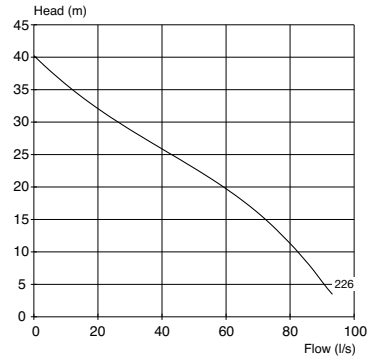

Rated power: 18kW  
Weight: 141kg



Dimensions:  
Max. height: 955mm  
Max. width: 500mm  
Discharge: Ø - 6"  
Strainer hole: 10x12mm

## Flygt BS 2670

### BS 2670 HT

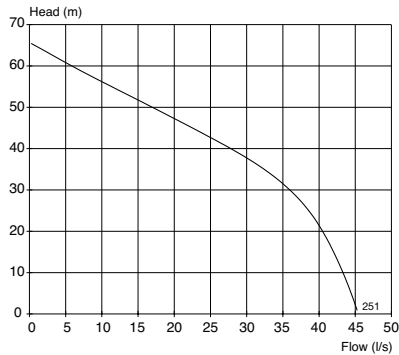

Rated power: 18kW  
Weight: 141kg



Dimensions:  
Max. height: 955mm  
Max. width: 480mm  
Discharge: Ø - 4"  
Strainer hole: 10x12mm

## Flygt BIBO 2800 Range

For decades whenever a dewatering challenge seemed too tough or too harsh, the answer has been simple; Flygt BIBO.

From the product brand and pumps that set the standard in dewatering comes a new and superior series of submersible dewatering pumps: Flygt BIBO 2800 series. It still has the iconic look; a shape that means stability and robustness. Inside the pumps you will find the latest technology such as the DuraSpin hydraulic system and plug-in seal. The range handles flows of up to 100 l/s with heads to 90 m and available with power ratings from 3.7 to 18kW.

Specifically targeted at mining operations, tunnelling and construction site applications.



## Flygt BS 2840

### BS 2840 MT

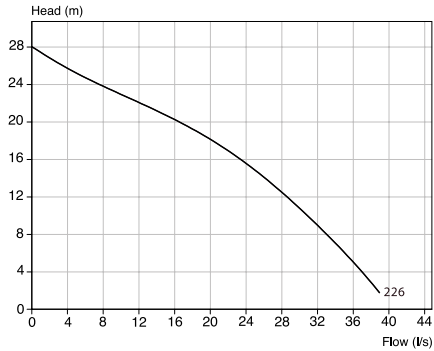

Rated power: 5kW  
Weight: 56kg



Dimensions:  
Height: 762mm  
Width: 367mm  
Discharge: 100mm

## Flygt BS 2860

### BS 2860 MT

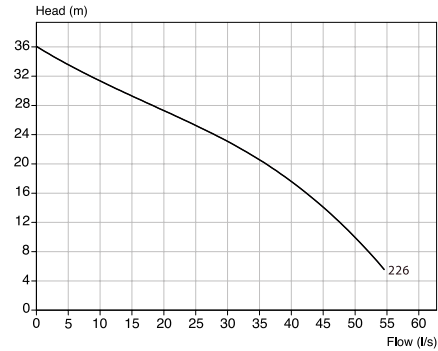

Rated power: 10kW  
Weight: 91kg



Dimensions:  
Height: 889mm  
Width: 425mm  
Discharge: 150mm

### BS 2840 HT



Rated power: 6kW  
Weight: 56kg



Dimensions:  
Height: 762mm  
Width: 367mm  
Discharge: 80mm

### BS 2860 HT

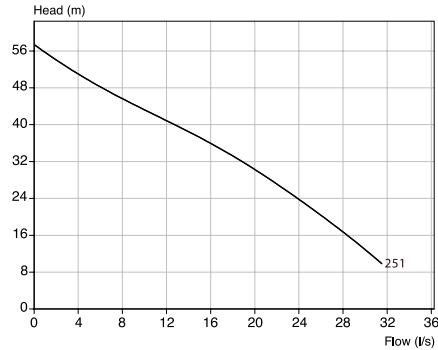

Rated power: 10kW  
Weight: 91kg



Dimensions:  
Height: 889mm  
Width: 425mm  
Discharge: 100mm

# Flygt BS 2870

## BS 2870 MT

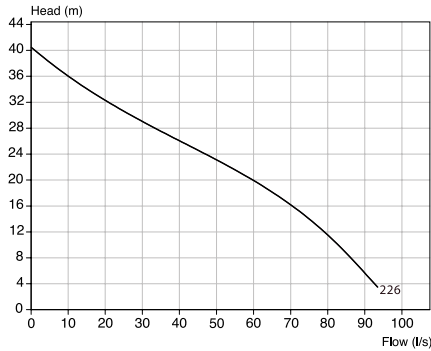

Rated power: 18kW  
Weight: 125kg



Dimensions:  
Height: 991mm  
Width: 500mm  
Discharge: 150mm

## BS 2870 HT

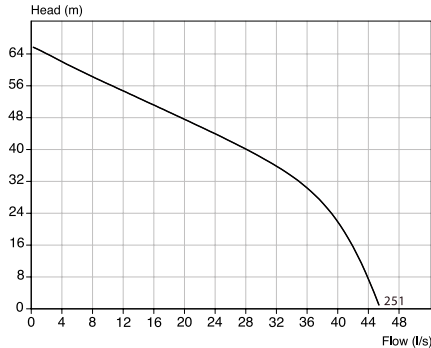

Rated power: 18kW  
Weight: 125kg



Dimensions:  
Height: 991mm  
Width: 500mm  
Discharge: 100mm

# Flygt 2000 Series Electrical Information

Pump Model	kW (Shaft Power)	Voltage	Phase	FLC Amps	DOL Starting Current AMPS	Starting Method	Minimum Generator in kVA to Start/Run
BS2125	8.0	400	3	15.0	125	DOL	90
BS2151	20.0	400	3	35.0	281	SOFT	100
BS2201	37.0	400	3	65.0	430	SOFT	150
BS2250	54.0	400	3	104.0	590	SOFT	450
BS2400	90.0	400	3	148.0	1245	SOFT	425
KS2610	0.9	110	1	11.0	38	CAP	5
KS2610	1.2	400	3	2.7	12	DOL	10
BS2620	2.2	400	3	4.7	27	DOL	20
BS2640	5.6	400	3	11.0	48	DOL	35
BS2660	10.0	400	3	19.0	107	DOL	75
BS2670	18.0	400	3	32.0	213	DOL	150
BS2840	5.6	400	3	11.0	78	DOL	55
BS2860	10.0	400	3	19.0	115	DOL	80
BS2870	18.0	400	3	33.0	238	SOFT	85

When two pumps are driven by the same generator, the rating required is 1.5 times that indicated for a single pump

Some form of time lag should be connected to prevent both pumps from starting simultaneously, unless the generator has been selected for pumps to start simultaneously.

The Information contained within this document is for guidance only and is accurate to the best of our knowledge at time of going to print.

## Flygt Bibo Alpha

### Introducing a new generation of dewatering pumps.

Bibo Alpha is a true plug and play pump, always adapting to optimise efficiency thanks to integrated intelligence.

To meet the increasing needs from the mining and construction industries to lower the total cost of pumping water, this pump is developed to be extremely robust, compact, stable and just as quick and easy to set-up as a traditional pump.

This is the first submersible dewatering pump that adjusts to a flow and head performance field instead of a static curve to meet the needs of any application.

This new technology provides a new level of flexibility adapted to today's and future needs in dewatering.

- Integrated control system
- High efficiency permanent magnet motor
- Built-in pressure sensor
- Leakage sensor
- Hydraulic volute design

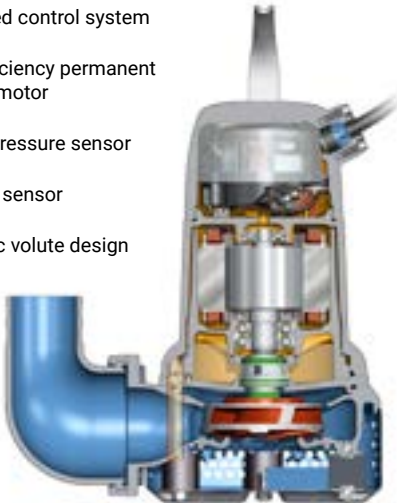

## Flygt Bibo Alpha

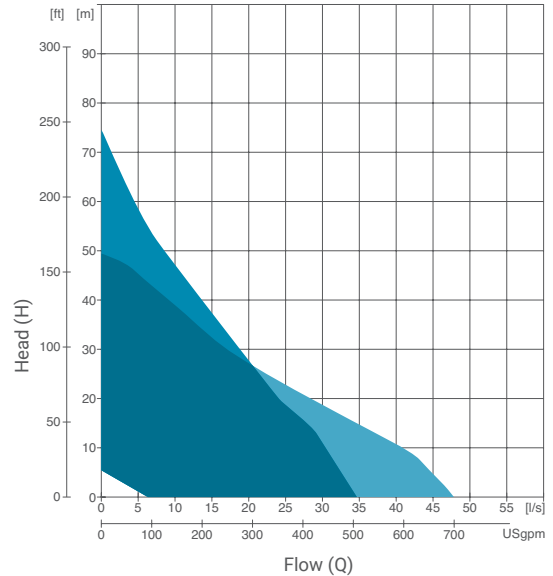

Voltage (V)	Rated current (A)	Starting current (A)
380	13.50	13.50
400	12.83	12.83
415	12.36	12.36
440	11.66	11.66
460	11.15	11.15
480	10.69	10.69

## Flygt Bibo Alpha

Denomination	50Hz	60Hz
Product code	2960.180	
Installation	Portable (S)	
Discharge connection	3" & 4"	
Impeller characteristics	HT: High head wear resistant impeller with DuraSpin MT: Medium head wear resistant impeller with DuraSpin	

### Process data

Liquid temperature	40°C	104°F
Depth of immersion	max 20 m	max 65 ft
Liquid density	max 1,100 kg/m <sup>3</sup>	max 9.2 lb/US gal
Strainer hole dimension	Ø10 mm	Ø0.39"
pH of pumped liquid	pH 5–8	

### Motor data

Frequency	50 Hz	60 Hz
Insulation class	H (180°C)	H (356°F)
Voltage variation	max +/- 10%	
Voltage imbalance	< 3%	

### Monitoring equipment

Leakage sensor	FLS 40, direction independent sensor	
Pressure sensor	Absolute pressure sensor, 0–2 bar	

### Cables

Submersible cable	SUBCAB®	
-------------------	---------	--

## Flygt Bibo Alpha

### Materials

Outer casing	Aluminum	
Impeller	Hard-Iron™	
Wear parts	Hard-Iron™ /Cast iron	
Stator housing	Aluminum	
Strainer	Stainless steel	
Shaft	Stainless steel	
O-rings	Nitrile rubber	
Discharge connection	Aluminum	

### Weight & dimensions

Weight (excl. cable)	68 kg	150 lbs
Height	658 mm	25.9"
Width	500–523 mm	19.69–20.59"

### Options

Shielded cable	SHD/GC (Canada)	
	Quick couplings	
	Zinc anodes	

### Rating

	380–480 V	
	120–4000 rpm	
	7.4 kW	10 hp

## Flygt Concertor™

To meet the growing challenges of modern wastewater, we're proud to introduce Flygt Concertor™, a breakthrough in wastewater pumping.

### A new way of thinking

Using a combination of advanced software functions and state-of-the-art hardware, Flygt Concertor™ senses the operating conditions of its environment and adapts the pumping performance in real time, making smart decisions and providing feedback to pumping station operators.

### One powerful solution, unlimited possibilities

Flygt Concertor™ combines a fully integrated control system with IE4 equivalent motor efficiency, our patented Adaptive N-hydraulics and intelligent functionalities such as clog detection and pump cleaning as well as soft start and motor protection.



## Flygt Concertor™

### Flygt Concertor™ N – State-of-the-art N-hydraulics

A new generation of our Adaptive N-technology enables high efficiency and lower energy usage. The Adaptive N-impeller moves axially upward when needed, allowing bulky fibrous material and debris to pass through smoothly. After the debris has passed, the hydraulic pressure returns the impeller to its original position. Not only does this prevent clogging and reduce stress on the shaft, seals and bearings, but it enables a sustained low usage of energy. As with all Flygt N-pumps, this feature delivers constant self-cleaning functionality.

Flygt Concertor™ offers a pump performance field covering a wide range of pump curves. No need for the perfect station design data. No need for a large inventory. One pump can be adjusted to suit specific conditions without having to change impeller diameters or motor sizes.

- Selection from a performance field instead of a fixed performance curve allows for enhanced operational flexibility
- Performance can be fine-tuned and pre-selected without changing the impeller
- Allows direct connection of the motor cable to the existing control panel contactor. Supply requires short circuit protection
- Connects to DOL starter (No overload required) can also be connected to star delta starter provided the configuration meets with certain criteria – please contact Xylem for details
- Anti-clogging protocol
- Advanced motor protection
- Adjustable performance with service tool via Laptop



# Flygt Concertor™

## Easier product selection and reduced inventory

With Flygt Concertor™, pump selection has never been easier due to the unlimited number of performance curves and enables pump performance to be easily changed on site or remotely.

## Choose from a performance field

With Flygt Concertor™, you can now choose the exact pump performance from a field rather than from fixed curves. This simplifies the selection process, since calculating your exact duty point is no longer critical.

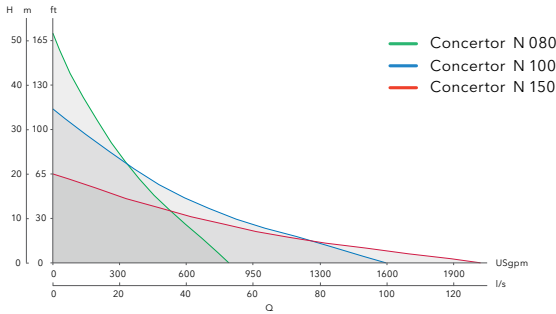

Model	Kw (shaft)	Discharge Size		
		80mm	100mm	150mm
N6020	5.5	X	X	X
N6020	7.3	X	X	N/A

Guide rail sliding bracket/flange 80mm dia. Adapter Claw  
 Guide rail sliding bracket/flange 100mm dia. Adapter Claw  
 Guide rail sliding bracket/flange 150mm dia. Adapter Claw



Supply: 400/3/50

Motor: IE4 Synchronous concentrated windings, permanent magnet motor

Rated power: 2.2kW – 7.3kW depending upon configuration

Hydraulics: Adaptive N Impeller c/w guide pin

Discharge size: 80mm – 150mm depending on model

Speed range: 500-3600 RPM

Cooling system: Liquid free heat conduction technology

# Flygt Concertor™

## Replacement of 3000 series by Flygt Concertor™ N

Xylem Rental will configure the Flygt Concertor™ pump with the correct motor rating and performance characteristics to enable it to replace the conventional Flygt 3085, 3102, 3127 and 3153 pump models.

Model	Impeller	Rated Shaft Power	DN	Concertor	DN	* Concertor Maximum Shaft Power
N 3085 MT	462	1.3	80	Concertor N 80	80	2.2
N 3085 MT	463	1.3	80	Concertor N 80	80	2.2
N 3085 MT	460	2.0	80	Concertor N 80	80	2.2
N 3085 MT	461	2.0	80	Concertor N 80	80	2.2
N 3085 MT	462	2.0	80	Concertor N 80	80	2.2
N 3085 MT	463	2.0	80	Concertor N 80	80	2.2
N 3085 SH	253	2.4	80	Concertor N 80	80	4.0
N 3085 SH	254	2.4	80	Concertor N 80	80	4.0
N 3085 SH	255	2.4	80	Concertor N 80	80	2.2
N 3085 SH	256	2.4	80	Concertor N 80	80	2.2
N 3102 LT	420	3.1	100	Concertor N 100	100	4.0
N 3102 LT	421	3.1	100	Concertor N 100	100	4.0
N 3102 LT	423	3.1	100	Concertor N 100	100	2.2
N 3102 LT	420	3.1	150	Concertor N 150	150	4.0
N 3102 LT	421	3.1	150	Concertor N 150	150	4.0
N 3102 LT	423	3.1	150	Concertor N 150	150	2.2
N 3102 SH	255	4.2	80	Concertor N 80	80	4.0
N 3102 SH	256	4.2	80	Concertor N 80	80	4.0
N 3102 MT	460	3.1	100	Concertor N 100	100	4.0
N 3102 MT	461	3.1	100	Concertor N 100	100	4.0
N 3102 MT	462	3.1	100	Concertor N 100	100	4.0
N 3102 MT	463	3.1	100	Concertor N 100	100	2.2
N 3102 MT	464	3.1	100	Concertor N 100	100	2.2
N 3127 HT	488	4.7	100	Concertor N 100	100	4.0
N 3127 HT	489	4.7	100	Concertor N 100	100	4.0
N 3127 HT	486	5.9	100	Concertor N 100	100	7.3
N 3127 HT	487	5.9	100	Concertor N 100	100	5.5
N 3127 HT	488	5.9	100	Concertor N 100	100	4.0
N 3127 HT	489	5.9	100	Concertor N 100	100	4.0
N 3127 SH	245	7.4	80	Concertor N 80	80	7.3
N 3127 SH	246	7.4	80	Concertor N 80	80	7.3
N 3127 SH	247	7.4	80	Concertor N 80	80	5.5
N 3127 SH	248	7.4	80	Concertor N 80	80	5.5
N 3127 LT	424	5.9	150	Concertor N 150	150	5.5
N 3127 LT	425	4.7	150	Concertor N 150	150	4.0
N 3127 LT	425	5.9	150	Concertor N 150	150	4.0
N 3127 LT	426	4.7	150	Concertor N 150	150	4.0
N 3127 LT	426	5.9	150	Concertor N 150	150	4.0
N 3127 MT	437	5.9	100	Concertor N 100	100	5.5
N 3127 MT	437	5.9	150	Concertor N 150	150	5.5
N 3127 MT	438	4.7	100	Concertor N 100	100	5.5
N 3127 MT	438	4.7	150	Concertor N 150	150	5.5
N 3127 MT	438	5.9	100	Concertor N 100	100	5.5
N 3127 MT	438	5.9	150	Concertor N 150	150	5.5
N 3127 MT	439	4.7	100	Concertor N 100	100	4.0
N 3127 MT	439	4.7	150	Concertor N 150	150	4.0
N 3127 MT	439	5.9	100	Concertor N 100	100	4.0
N 3127 MT	439	5.9	150	Concertor N 150	150	4.0
N 3153 MT	436	7.5	150	Concertor N 150	150	7.3
N 3153 HT	454	7.5	100	Concertor N 100	100	7.3
N 3153 HT	455	7.5	100	Concertor N 100	100	7.3
N 3153 HT	456	7.5	100	Concertor N 100	100	7.3
N 3153 SH	275	11.0	80	Concertor N 80	80	7.3
N 3153 SH	276	11.0	80	Concertor N 80	80	7.3

\*Xylem Rental will configure the Concertor™ pump with the correct Motor rating and performance characteristics prior to delivery.

# Flygt 3000 N Series Solids Handling Pumps

## N Pump Technology

Sustained high efficiency for wastewater handling with its unique semi-open, self-cleaning impeller, the N-pump series can handle fluids with high concentrations of fibrous material, whilst still maintaining a high level of pumping efficiency over long duty periods. The special relief groove in the volute reduces the risk of clogging by creating a self-cleaning flow path through the pump.

## N Series Pumps

N series pumps are available, contact your local Xylem representative for curve details: N 3085, N 3102, N 3127, N 3153, N 3171, N 3202, N 3301



## Adaptive N-impellers



The Adaptive N-hydraulics further improves the self-cleaning characteristics of N-technology with unmatched clog-free performance. This is achieved through the unique axial movement of the Adaptive N-impeller.

The Adaptive N-impeller is designed to move axially upwards when needed, allowing the most bulky of rags and toughest of debris to pass through smoothly. After the debris has passed, the hydraulic pressure returns the impeller to its original position.

The axial movement of this hydraulic reduces stress on the shaft, seals, and bearings, thereby extending their lifespan. Ultimately clog-free performance requires almost none, or at the very most, simple maintenance and servicing. All in all, the Adaptive N-hydraulics is your assurance of highly economical and reliable pumps that give you peace of mind.

# Flygt N 3085 and N 3102

## N 3085 MT

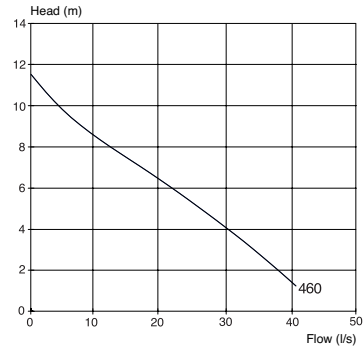

Discharge size: 75mm  
 Height: 655mm  
 Motor rating: 2.0kW  
 Weight: 71kg  
 Maximum width: 450mm

Impeller Code	No. of vanes	Outlet dia. mm NP vers	Motor rating, kW	rpm	Available versions
460 MT	2	80	2.0	1400	NP/NS/NT

## N 3102 MT/SH

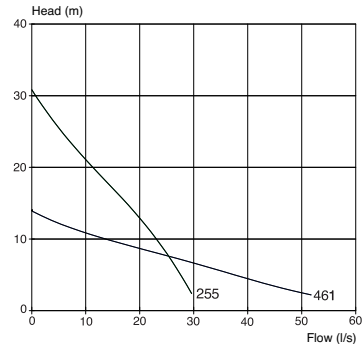

Discharge size: 80mm/100mm  
 Height: 705mm  
 Motor rating: 3.1/4.2kW  
 Weight: 116kg  
 Maximum width: 610mm

Impeller Code	No. of vanes	Outlet dia. mm NP vers	Motor rating, kW	rpm	Available versions
461 MT	2	100	3.1	1440	NP/NS
255 SH	2	80	4.2	2890	NP/NS

## Flygt N 3127 and N 3153

### N 3127 MT/HT

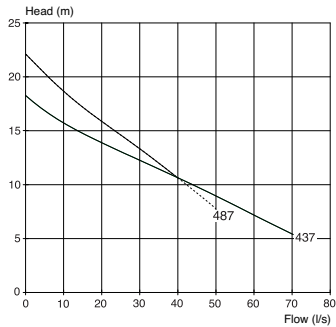

Discharge size: 100/150mm  
 Height: 765mm  
 Motor rating: 5.9kW  
 Weight: 170kg  
 Maximum width: 725mm

Impeller Code	No. of vanes	Outlet dia. mm NP vers	Motor rating, kW	rpm	Available versions
437 MT	2	100/150	5.9	1450	NP/NS/NT
487 HT	2	100	5.9	1450	NP/NS/NT

### N 3153 LT/MT

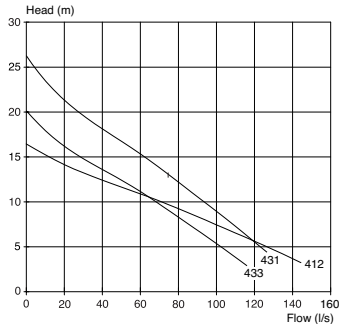

Discharge size: 150/200mm  
 Height: 1068mm  
 Motor rating: 13.5kW  
 Weight: 252kg MT 279kg LT  
 Maximum width: 834mm

Impeller Code	No. of vanes	Outlet dia. mm NP vers	Motor rating, kW	rpm	Available versions
412 LT	2	200	13.5	1455	NP/NT/NS
431 MT	2	150	13.5	1455	NP/NT/NS
433 MT	2	150	13.5	1455	NP/NT/NS

## Flygt N 3153 and N 3171

### N 3153 HT/SH

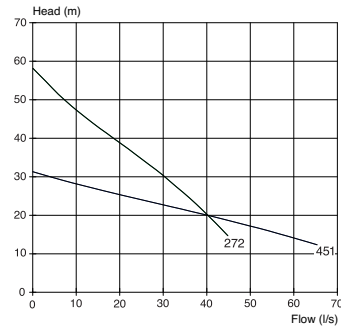

Discharge size: 80/100mm  
 Height: 1052mm  
 Motor rating: 13.5/15.0kW  
 Weight: 242kg  
 Maximum width: 763mm

Impeller Code	No. of vanes	Outlet dia. mm NP vers	Motor rating, kW	rpm	Available versions
451 HT	2	100	13.5	1455	NP/NT/NS
272 SH	2	80/100	15.0	2910	NP/NT/NS

### N 3171 LT MT and HT

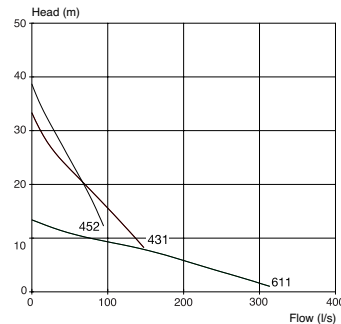

Discharge size: 100/250mm  
 Height: 1299mm  
 Motor rating: 15/22kW  
 Weight: 460kg  
 Maximum width: 1151mm

Impeller Code	No. of vanes	Outlet dia. mm NP vers	Motor rating, kW	rpm	Available versions
611 LT	2	250	15.0	965	NP/NS/NT
431 MT	2	150	22.0	1460	NP/NS/NT
452 HT	2	100	22.0	1460	NP/NS/NT

## Flygt N 3171 and N 3202

### N 3171 SH

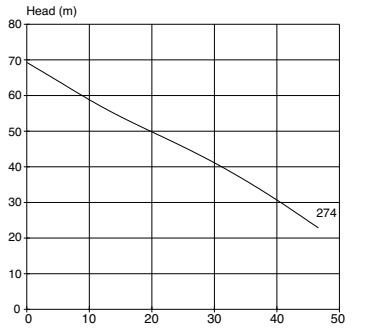

Discharge size: 100mm  
 Height: 1179mm  
 Motor rating: 22kW  
 Weight: 366kg  
 Maximum width: 884mm

Impeller Code	No. of vanes	Outlet dia. mm NP vers	Motor rating, kW	rpm	Available versions
274 SH	2	108	22.0	2925	NP/NS/NT

### N 3202 LT MT and HT

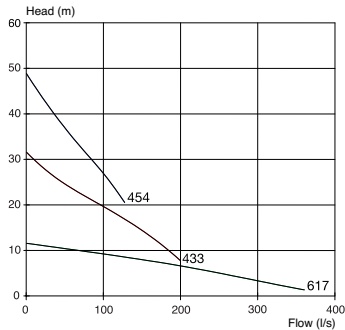

Discharge size: 150/300mm  
 Height: 1571mm  
 Motor rating: 22/45kW  
 Weight: 900kg  
 Maximum width: 1439mm

Impeller Code	No. of vanes	Outlet dia. mm NP vers	Motor rating, kW	rpm	Available versions
617 LT	2	250	22.0	970	NP/NS/NT
433 MT	2	200	30.0	1475	NP/NS/NT
454 HT	2	150	45.0	1450	NP/NS/NT

## Flygt N 3301

### N 3301 LT and MT 37/55kW

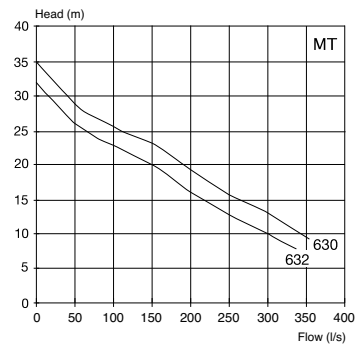
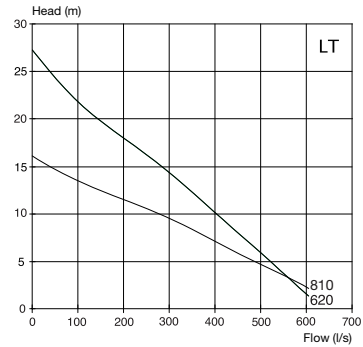

Discharge size: 250/350mm  
 Height NS: 1665/1705mm  
 Motor rating: 37/55kW  
 Weight: 1110/1430kg  
 Maximum width NS: 1439mm

Impeller Code	No. of vanes	Outlet dia. mm NP vers	Motor rating, kW	rpm	Available versions
810 LT	2	350	37	735	NP/NT/NS/NZ
620 LT	2	250	55	985	NP/NT/NS/NZ
630 MT	2	250	55	985	NP/NT/NS/NZ
632 MT	2	250	55	985	NP/NT/NS/NZ

# Flygt N 3301

## N 3301 HT 55kW

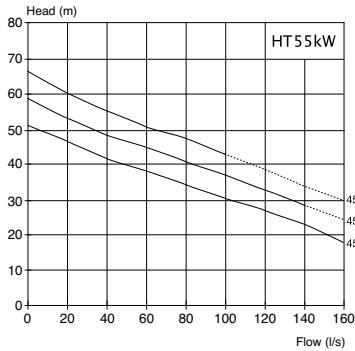

## N 3301 454 HT Impeller 70kW VFD Curves

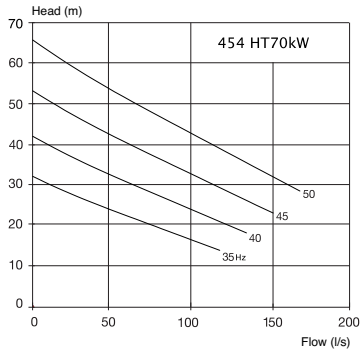

Discharge size: 150mm  
 Height NS: 1641mm  
 Motor rating: 55/70kW  
 Weight: 920kg  
 Maximum width NS: 1242mm

Impeller Code	No. of vanes	Outlet dia. mm NP vers	Motor rating, kW	rpm	Available versions
454 HT	2	150	70	1475	NP/NT/NS/NZ
454 HT	2	150	55	1400	NP/NT/NS/NZ
456 HT	2	150	55	1400	NP/NT/NS/NZ
458 HT	2	150	55	1400	NP/NT/NS/NZ

A selection of impellers are available on request; also Variable Frequency Drive Starters



# Flygt N Type Chopper Pumps

## Introduction

Chopper pumps with N-impeller Technology. Flygt Chopper pumps have the unique patented N-impeller along with a hard iron chopper ring which drastically reduces the risk of clogging. Rugged, wear resistant and self cleaning, it cuts through solids without clogging or sacrificing pump efficiency.

The Flygt Chopper pump range brings to an end troublesome and costly clogging with its heavy-duty and highly dependable chopping abilities. By adding the chopper function to the well proven Flygt N-pump, outstanding performance in heavy duty applications has been achieved. This new pump design has undergone extensive testing in the field. The results from these tests show considerably fewer running problems and considerably lower energy consumption.

Typical applications:

- Agriculture
- Aquaculture
- Food processing
- Pulp and paper
- Harsh wastewater facilities



## N 3127 Chopper MT

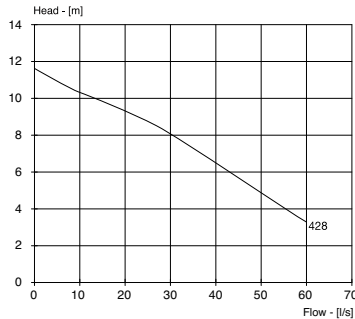

Discharge size: 100/150mm  
 Height NS: 765mm  
 Motor rating: 4.7kW  
 Weight: 170kg  
 Maximum width NS: 725mm

Impeller Code	No. of vanes	Outlet dia. mm NP vers	Motor rating, kW	rpm	Available versions
428 MT	2	100/150	4.7	1455	NP/NS/NT/NZ

# Flygt N Type Chopper Pumps

## N 3153 Chopper MT and HT

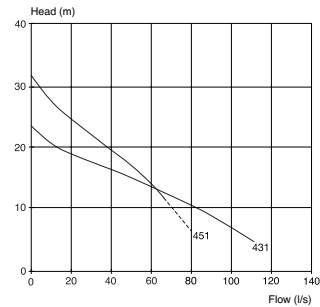

Discharge size: 100/150mm  
 Height NS: 1068mm  
 Motor rating: 13.5kW  
 Weight: 252kg  
 Maximum width NS: 763mm

Impeller Code	No. of vanes	Outlet dia. mm NP vers	Motor rating, kW	rpm	Available versions
431 MT	2	150	13.5	1455	NP/NS/NT
451 HT	2	100	13.5	1455	NP/NS/NT

## N 3171 Chopper MT and HT

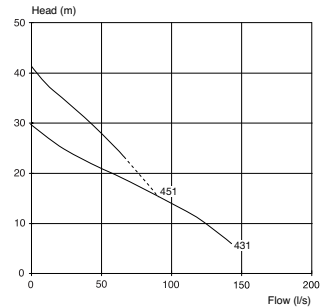

Discharge size: 100/150mm  
 Height NS: 1225mm  
 Motor rating: 22.0kW  
 Weight: 362kg  
 Maximum width NS: 884mm

Impeller Code	No. of vanes	Outlet dia. mm NP vers	Motor rating, kW	rpm	Available versions
431 MT	2	150	22.0	1460	NP/NS/NT
451 HT	2	100	22.0	1460	NP/NS/NT

# Flygt Great and Grey Solids Handling Pumps

## Introduction

After revolutionising the market for small and midrange wastewater pumps, the Flygt N pumps are now available in larger units.

- Incorporating the N pump technology the potential for blockage is substantially reduced
- Due to sustained efficiency, energy costs can be cut by up to 50%
- Heads of up to 90mts achieved
- Flows in excess of 700l/s

## Applications

- General by-pass over-pumping
- Pump replacement
- Application proving
- Storm water handling
- Industrial effluent handling
- Irrigation

Pumps from 90 to 250kW available to rent in NP/NS/NT and NZ build (see Page 42). Ex units available on request.



# Flygt N Great and Grey Installation Methods

Flygt centrifugal pumps are designed to pump wastewater containing solids and fibres in suspension. The pump can also be used for pumping raw water.

Liquid temperature:	max 40°C (105°F)
Liquid density:	max 1100kg/m <sup>3</sup>
The pH of the pumped liquid:	6 - 11
Depth of immersion:	max 20 m (65 ft)

For pumping in an explosive or flammable environment the pump can be ATEX certified.

The Flygt pump is fully submersible, compact and easy to install. It is available in four versions, depending of the type of installation:

NP: This system with guide bars and discharge connection permits automatic connection of the pump to the discharge line. The pump can be lifted up for inspection without anyone having to enter the sump. The pump works completely or partially submerged under water.

NS: A transportable pump designed for operating completely or partially submerged in the pump liquid. It is equipped with base stand and hose connection.

NT: The pump is installed vertically dry on a base stand and connected directly to the inlet and outlet lines. The submersible design of the pump prevents damage in the event of flooding.

NZ: The pump is installed horizontally dry on a base stand and connected directly to the inlet and outlet lines. The submersible design of the pump prevents damage in the event of flooding.

For other applications, contact your local sales representative for information.

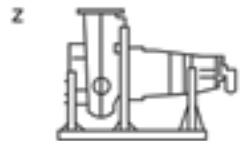

# Flygt N 3315

## N 3315 LT 62kW 810/490mm

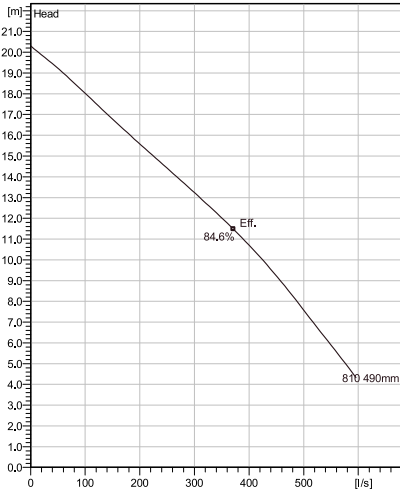

Rated power: 62kW  
 Weight: 1530kg  
 Dimensions:  
 Height: 2305mm  
 Width: 1140mm  
 Discharge: 350mm

Impeller Code	No. of vanes	Outlet dia. mm NP vers	Motor rating, kW	rpm	Available versions
810	3	350	62	735	NP/NS/NT/NZ

# Flygt N 3315

## N 3315 90kW 620/470mm

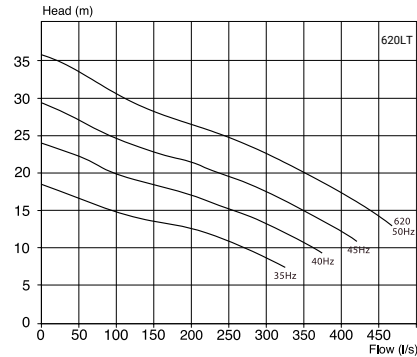

Rated power: 90kW  
 Weight: 1330kg  
 Dimensions:  
 Height: 2056mm  
 Width: 1330mm  
 Discharge: 300mm

Impeller Code	No. of vanes	Outlet dia. mm NP vers	Motor rating, kW	rpm	Available versions
620	3	300	90	985	NP/NS/NT/NZ

## N 3315 105kW 451/440mm

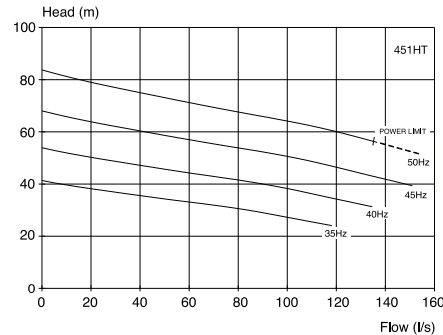

Rated power: 105kW  
 Weight: 1150kg  
 Dimensions:  
 Height: 1992mm  
 Width: 1017mm  
 Discharge: 150mm

Impeller Code	No. of vanes	Outlet dia. mm NP vers	Motor rating, kW	rpm	Available versions
451	3	150	105	1480	NP/NS/NT/NZ

## Flygt N 3231

### N 3231 85kW 480/360mm

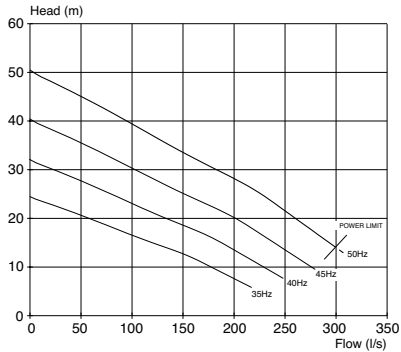

Rated power: 85kW  
 Weight: 1380kg  
 Dimensions:  
 Max. height: 2060mm  
 Max. width: 1570mm

Impeller Code	No. of vanes	Outlet dia. mm NP vers	Motor rating, kW	rpm	Available versions
480-360	3	200	85	1475	NP/NS/NT/NZ

### N 3231 105kW 480/400mm

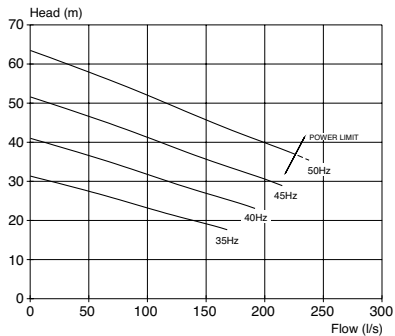

Rated power: 105kW  
 Weight: 1590kg  
 Dimensions:  
 Max. height: 2060mm  
 Max. width: 1570mm

Impeller Code	No. of vanes	Outlet dia. mm NP vers	Motor rating, kW	rpm	Available versions
480-400	3	200	105	1480	NP/NS/NT/NZ

## Flygt N 3231

### N 3231 125kW 470/370mm

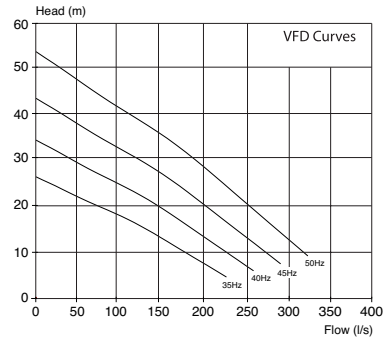

Rated power: 125kW  
 Weight: 1760kg  
 Dimensions:  
 Max. height: 2185mm  
 Max. width: 1390mm

Impeller Code	No. of vanes	Outlet dia. mm NP vers	Motor rating, kW	rpm	Available versions
470-370	3	200	125	1450	NP/NT/NS/NZ

### N 3231 170kW 470/490mm

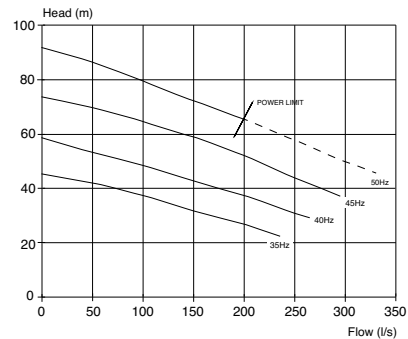

Rated power: 170kW  
 Weight: 1760kg  
 Dimensions:  
 Max. height: 2305mm  
 Max. width: 1570mm

Impeller Code	No. of vanes	Outlet dia. mm NP vers	Motor rating, kW	rpm	Available versions
470-490	3	200	170	1480	NP/NT/NS/NZ

A selection of impellers are available on request; also Variable Frequency Drive Starters

## Flygt N 3231

### N 3231 170kW 480/490mm

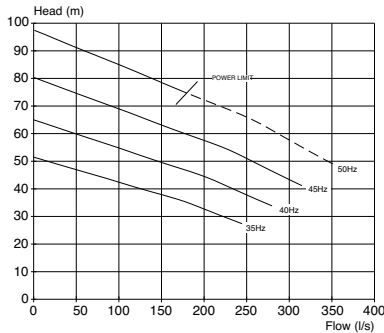

Rated power: 170kW  
Weight: 1760kg  
Dimensions:  
Max. height: 2305mm  
Max. width: 1570mm

Impeller Code	No. of vanes	Outlet dia. mm NP vers	Motor rating, kW	rpm	Available versions
480-490	3	200	170	1480	NP/NS/NT/NZ

### N 3231 215kW 480/490mm

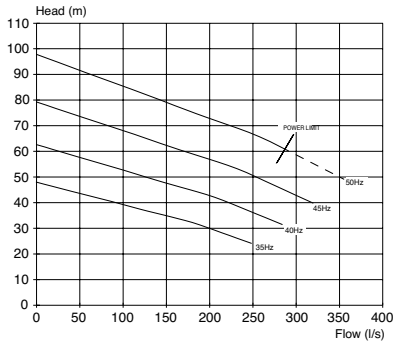

Rated power: 215kW  
Weight: 1910kg  
Dimensions:  
Max. height: 2305mm  
Max. width: 1570mm

Impeller Code	No. of vanes	Outlet dia. mm NP vers	Motor rating, kW	rpm	Available versions
480-490	3	200	215	1485	NP/NS/NT/NZ

## Flygt N 3312

### N 3312 100kW 670/450mm

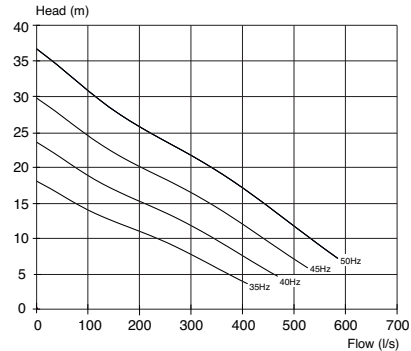

Rated power: 100kW  
Weight: 1975kg  
Dimensions:  
Max. height: 2240mm  
Max. width: 1650mm

### N 3312 180kW 670/545mm

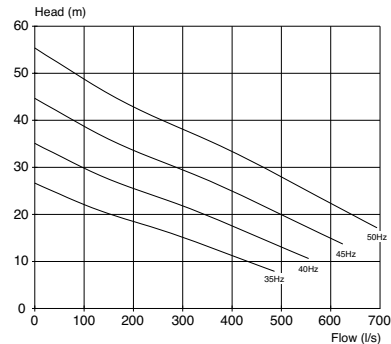

Rated power: 180kW  
Weight: 2275kg  
Dimensions:  
Max. height: 2975mm  
Max. width: 1875mm

Impeller Code	No. of vanes	Outlet dia. mm NP vers	Motor rating, kW	rpm	Available versions
670-450	3	300	100	985	NP/NT/NS/NZ
670-545	3	300	180	990	NP/NT/NS/NZ

A selection of impellers are available on request; also Variable Frequency Drive Starters

## Flygt N 3312 / N 3356

### N 3312 250kW 670/585mm

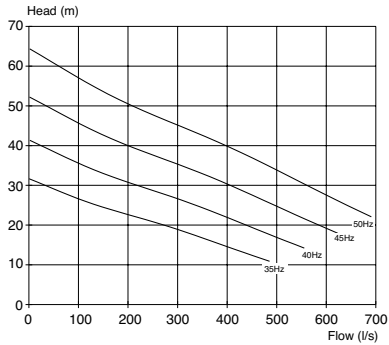

Rated power: 250kW  
 Weight: 3125kg  
 Dimensions:  
 Max. height: 2975mm  
 Max. width: 1875mm

Impeller Code	No. of vanes	Outlet dia. mm NP vers	Motor rating, kW	rpm	Available versions
670-585	3	300	250	990	NP/NS/NT/NZ

## Flygt N 3356 / N 3400

### N 3356 100kW 670/475mm

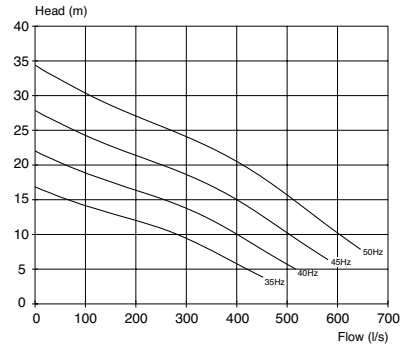

Rated power: 100kW  
 Weight: 1750kg  
 Dimensions:  
 Max. height: 2275mm  
 Max. width: 1900mm

Impeller Code	No. of vanes	Outlet dia. mm NP vers	Motor rating, kW	rpm	Available versions
670-475	3	350	100	985	NP/NT/NZ

### N 3356 90kW 670/470

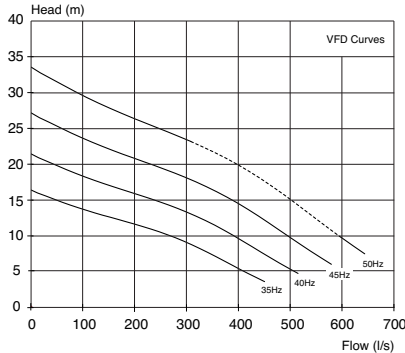

Rated power: 90kW  
 Weight: 2200kg  
 Dimensions:  
 Max. height: 2400mm  
 Max. width: 1875mm

Impeller Code	No. of vanes	Outlet dia. mm NP vers	Motor rating, kW	rpm	Available versions
670-470	3	350	90	985	NP/NT/NS/NZ

### N 3400 250kW 670/575mm

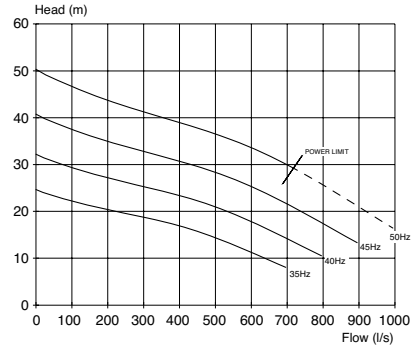

Rated power: 250kW  
 Weight: 3750kg  
 Dimensions:  
 Max. height: 3428mm  
 Max. width: 1900mm

Impeller Code	No. of vanes	Outlet dia. mm NP vers	Motor rating, kW	rpm	Available versions
670-575	3	400	250	990	NP/NT/NZ

# Flygt Channel Impeller Pump

## C 3501 125kW

Shrouded multi-channel impeller pumps with large throughlets and single volute pump casing for liquids containing solids and fibres. Cast iron design with double sealing technology.

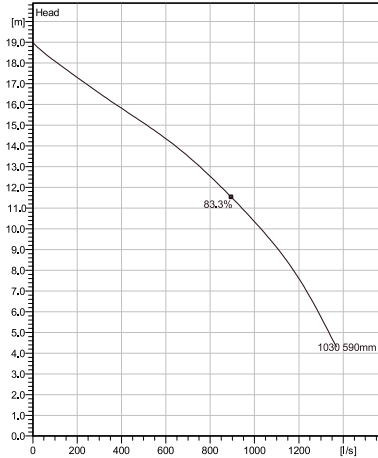

Rated power: 125kW  
 Weight: 4000kg  
 Dimensions:  
 Max. height: 2815mm  
 Max. width: 1500mm

Impeller Code	No. of vanes	Outlet dia. mm NP vers	Motor rating, kW	rpm	Available versions
1033xx	3	500	125	590	NP/NS/NT/NZ

# Flygt 3000 Series Pumps Electrical Information

Pump Model	kW (Shaft Power)	Voltage	Phase	FLC Amps	DOL Starting Current AMPS	Starting Method	Minimum Generator in kVA to Start/Run
3085	1.3	400	3	3.1	19	DOL	15
3085	2.0	400	3	4.5	19	DOL	15
3085	2.4	400	3	4.7	28	DOL	20
3102	3.1	400	3	6.9	33	DOL	25
3102	4.2	400	3	8.3	72	DOL	50
3127	4.7	400	3	9.6	56	DOL	40
3127	5.9	400	3	12.0	77	DOL	55
3127	7.4	400	3	14.0	114	DOL	80
3152 - 4 Pole	13.5	400	3	27.0	162	SOFT	40
3152 - 2 Pole	15.0	400	3	28.0	229	SOFT	55
3153	7.5	400	3	16.0	91	SOFT	25
3153	9.0	400	3	19.0	107	SOFT	25
3153	11.0	400	3	24.0	132	SOFT	35
3153 - 4 Pole	13.5	400	3	28.0	150	SOFT	35
3153 - 2 Pole	15.0	400	3	27.0	213	SOFT	50
3170	15.0	400	3	31.0	210	SOFT	50
3171	22.0	400	3	41.0	248	SOFT	60
3201	30.0	400	3	56.0	365	SOFT	85
3202	37.0	400	3	66.0	460	SOFT	110
3202	45.0	400	3	82.0	605	SOFT	150
3300	44.0	400	3	82.0	515	SOFT	150
3300	54.0	400	3	100.0	535	SOFT	150
3301 - 6 Pole LT	55.0	400	3	113.0	660	SOFT	225
3301 - 4 Pole MT	55.0	400	3	103.0	435	SOFT	150
3301	70.0	400	3	132.0	565	SOFT	195
3315 LT	62.0	400	3	124.0	660	VFD	200
3315 LT - 6 Pole	90.0	400	3	185.0	1160	VFD	195
3315 HT - 4 Pole	105.0	400	3	199.0	1105	VFD	210
3231 - 4 Pole	85.0	400	3	159.0	710	VFD	170
3231 - 4 Pole	105.0	400	3	200.0	955	VFD	210
3231 - 4 Pole	125.0	400	3	234.0	1525	VFD	245
3231 - 4 Pole	170.0	400	3	300.0	2020	VFD	315
3231 - 4 Pole	215.0	400	3	395.0	2945	VFD	415
3312 - 6 Pole	100.0	400	3	202.0	1150	VFD	210
3312 - 6 Pole	180.0	400	3	360.0	2215	VFD	375
3312 - 6 Pole	250.0	400	3	465.0	2645	VFD	485
3356 - 6 Pole	90.0	400	3	185.0	1160	VFD	195
3356 - 6 pole	100.0	400	3	202.0	1150	VFD	210
3400 - 6 Pole	250.0	400	3	465.0	2645	VFD	485
3501	125.0	400	3	269.0	1250	VFD	250

When two pumps are driven by the same generator, the rating required is approximately 1.5 times that indicated for a single pump.

Some form of time lag should be connected to prevent both pumps from starting simultaneously, unless the generator has been selected for that number of pumps to start simultaneously.

The information contained within this document is for guidance only and is accurate to the best of our knowledge at time of going to print.

## Flygt Dri-Prime Add on

### Self Priming Pump

Our inhouse designed and manufactured Dri-Prime rental add on solution for site applications where an electric Flygt pump is the pump of choice. Flygt submersible pumps, renowned for their exceptional performance and energy efficiency, can now be hired and equipped with a state-of-the-art Dri-Prime rental add on kit, enabling seamless operation in above-ground, multi-pump suction lift applications.

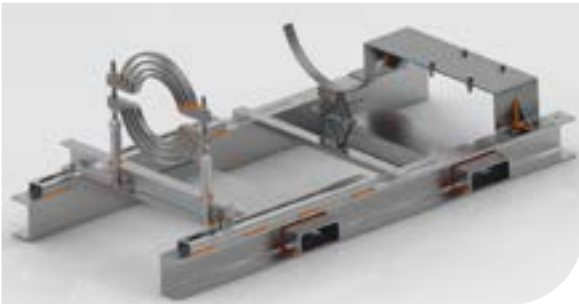

Technical Data:  
1.85m x 0.86m approximate height of 0.76m  
185kg structural steel

Flygt rental Dri-Prime add on provides the ability to self-prime Flygt submersibles, ensuring hassle-free setup and operation. With the Dri-Prime rental add on kit, self-priming the pump becomes a breeze, achieving maximum efficiency and allowing pumping tasks to be up and running swiftly.

## Flygt Dri-Prime Add on

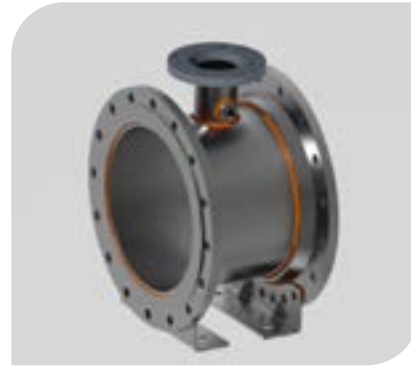

Convenience is key, and that's why our Flygt pumps with the Dri-Prime rental add-on kit are available for hire from our strategically located Xylem rental hubs across the UK. Xylem's nationwide presence ensures quick access to these high-performance pumps, no matter where your project is located.



With our new Dri-Prime rental add-on kit, maximum efficiency for operations and energy can be achieved in above-ground applications, all powered by clean electricity. Contact us today to experience the future of pumping technology.

# Lowara Clean Water Booster Set

## Lowara GHV20 Booster Set

Lowara GHV series booster sets are designed to transfer and increase the pressure of water, in the following applications:

- Hospitals
- Schools
- Public buildings
- Industries
- Hotels
- Sports facilities
- Mains water systems

The GHV series booster set is a variable speed pump set with two e-SV series multistage vertical pumps. Each pump is equipped with a HYDROVAR® frequency converter. This means the pumps are capable of variable speed operation. The pumps are installed on a single skid base and connected to each other by means of suction and delivery pipes complete with manifolds and isolation and non-return valves.

## Technical Information

Model: GHV20/66SV3/2AG150T  
- 2 pumps skid mounted c/w with panel and Hydrovar unit

Supply: 400/3/50  
Pump FLC: 27A, per pump  
Motor: IE3 Three phase surface motor  
Shaft power: 13kW  
Inlet: 150mm  
Discharge: 125mm  
Nominal flow: 15l/s  
Maximum flow: 23l/s  
Nominal head: 50m  
Maximum head: 76m  
Maximum working pressure: 7.7 Bar  
Panel & pumps protected to IP55  
Dimensions: 1551 L x 960 W x 1376 H  
Weight: 860kg



# Monitoring & Control

The same great knowledge and experience that builds the best pumps in the world lets you control and monitor your assets.

At Xylem we are continually striving to find ways to improve our customer experience, through the development of new systems and products to remotely monitor and control essential equipment, providing cost effective intelligent solutions.

As well as supplying the hardware such as pump controllers, sensors, electrical start equipment and control panels; we also have software for running the system.

The Flygt SCADA software provides PC based SCADA (Supervision, Control and Data Acquisition) know-how. The applications range from those operating in wastewater treatment plants and pump stations to products pumping ground water from building sites.

By combining these new system controls with our Service Solution provision, we can help to ensure the on-going quality and life of customers' pumps, whilst weekly electronic preventative checks increase the pumps operational effectiveness.

- Pump control panels
- Starters
- Level/pump/flow sensors
- Pump controller/supervision
- SCADA software systems
- Inverters VFD/VSD – PumpSmart/Smartun
- WITS accredited Telemetry Outstations/RTUs/Pump Controllers
- Harmonic surveys for drive installations
- System design/integration
- Design consultancy
- Energy audits
- Optimisation of assets
- Reduction of OPEX leading to better TOTEX
- Project management inc. CDM
- Solar panel demand calculation



## Rental Ultrasonic Controller Specification

- IP54 floor standing enclosure
- Lifting hook
- Rain canopy
- Cable storage hooks
- Controls up to 6 starters or VFD's
- Door interlocked isolator
- Door mounted siemens hydromanager 200 controller
- XPS 15 ultrasonic transducer head c/w 25m cable - measuring range: min. 0.3m - max. 15m
- Mains terminals – 110/230v SP supply
- Control terminals
- 4-20mA output



### Dimensions

- Height: 960mm
- Width: 420mm
- Depth: 400mm
- Weight: 25kg

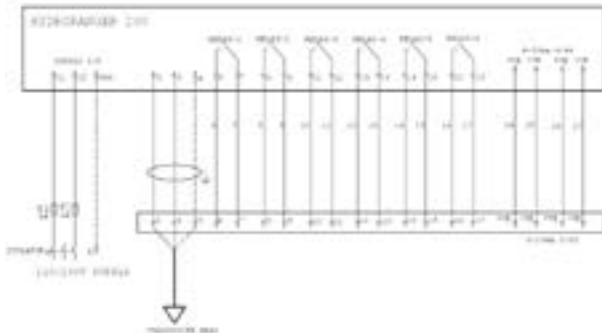

## Electrical Equipment

We specialise in electrical submersible pumps, therefore, it is logical that we are the experts when it comes to the starter and controls that are required for a temporary pumping installation. From a simple single phase starter to a complex multi pump 3 phase control panel, rental engineers are available to give advice on all aspects of electromotive power.

Our rental team carries a comprehensive range of starters, isolators, control equipment, alarm and monitoring devices. Sufficient cable to suit day-to-day usage is stocked both at Nottingham and at all rental depot locations. For the larger and more complex installations we are able to select and supply the appropriate extension cables and junction boxes to connect the pump to the control panel. We can also supply ATEX Certified "Ex" junction boxes and cables glands for use in hazardous areas. If level regulators (floats) are used as the level control we can supply the required I/S protection relays.



## Soft Starter Panel 2.2-15kW - Pump FLC 32A

### Specification

- IP54 Zintex panel
- Load break door interlocked isolator
- Soft starter
- Special wide ranging overload unit (WOL) to protect different size pumps
- Pump setting via keypad
- Earth leakage protection
- 1000 event data log
- USB port for up loading and downloading parameters
- Hand/auto switch
- Door mounted alphanumeric keypad
- Door mounted emergency stop (also to terminals)
- Klixon thermal trip circuit
- Inter-panel interlock system
- Motor & control connections wired to terminals
- 24vdc control for floats
- 24vdc 100ma for alarm
- 24vdc 500ma for the ultrasonic unit
- 24vac power supply customer use
- Eart stud terminal
- Main contractor
- (to provide isolation when WOL detects short circuit setting level)
- Avensor (telemetry) unit
- Aerial for Avensor
- Alarm signals wired to Avensor



### The heart of the panel

- Pin locked menu
- Adjustable pump range by amps
- Adjustable too many starts protection
- Electric overload
- Underload trip
- Electronic shear pin
- Thermal switch connections

### Digital display

- Running amps
- Hand, auto, running and tripped LED
- Start and stop pushbutton
- Last eight fault history
- Motor current
- Run hours
- Motor status
- Printable 1000 event data log

### Dimensions

- Height: 925mm
- Width: 400mm
- Depth: 400mm
- Weight: 30kg

## Soft Starter Panel 2.2-22kW - Pump FLC 44A

### Specification

- IP54 floor standing enclosure finished to RAL 2000 yellow orange
- Lifting hook
- Rain canopy
- Door interlocked isolator
- Control terminals
- 4-20mA output
- Load break door interlocked isolator
- Main contactor
- Emergency stop facility
- Built in by-pass contactor
- Door mounted keypads
- Earth leakage protection
- Local hand off auto remote selector switch
- Thermistor/klixon protection
- IS barrier for float circuit
- Fuse protection for control circuits
- 24v AC control circuit
- 415v~24vac control transformer
- Output terminals for motor connections
- I/O wired to terminals
- Interlock circuit
- Floats wired to terminals
- Telemetry connections wired to terminals
- Battery backup for telemetry
- 24v DC PSU
- Avensor (telemetry) unit
- Aerial for Avensor
- Alarm signals wired to Avensor
  1. Run
  2. Trip
  3. High level
  4. Power fail (In built from telemetry)
- Provision for ultrasonic down to terminals



### The heart of the panel

- Pin locked menu
- Adjustable pump range by AMPS
- Adjustable too many starts protection
- Wide rangin electronic overload max FLC 44A
- Underload trip
- Electronic shear pin

### Digital display

- Running amps
- Hand, auto, running and tripped LED
- Start and stop pushbutton
- Last eight fault history
- Motor current
- Run hours
- Motor status
- Printable 1000 event data log

### Dimensions

- Height: 925mm
- Width: 400mm
- Depth: 400mm
- Weight: 30kg

## Soft Starter Panel 22-90kW - Pump FLC 170A

### Specification

- IP54 floor standing enclosure finished to RAL 2000 yellow orange
- Lifting hook
- Rain canopy
- Door interlocked isolator
- Control terminals
- 4-20mA output
- Load break door interlocked isolator
- Main contactor
- Emergency stop facility
- Built in by-pass contactor
- Door mounted keypads
- Earth leakage protection
- Local hand off auto remote selector switch
- Thermistor/klixons protection
- IS barrier for float circuit
- Fuse protection for control circuits
- 24v AC control circuit
- 415v~24vac control transformer
- Output terminals for motor connections
- I/O wired to terminals
- Interlock circuit
- Floats wired to terminals
- Telemetry connections wired to terminals
- Battery backup for telemetry
- 24v DC PSU
- Avensor (telemetry) unit
- Aerial for Avensor
- Alarm signals wired to Avensor
  1. Run
  2. Trip
  3. High level
  4. Power fail (In built from telemetry)
- Provision for ultrasonic down to terminals

### Dimensions

- Height: 1570mm
- Width: 1000mm
- Depth: 400mm
- Weight: 160kg



### The heart of the panel

- Pin locked menu
- Adjustable pump range by amps
- Adjustable too many starts protection
- Wide Rangen electronic overload max flc 170A
- Underload trip
- Electronic shear pin

### Digital display

- Running AMPS
- Hand, auto, running and tripped LED
- Start and stop bush button
- Last eight fault history
- Motor current
- Run hours
- Motor status
- Printable 1000 event data log

## VFD Starter Panel 22kW - Pump FLC 48A

### Specification

The Variable Speed Drive multifunctional control panel for motors rated up to 22KW. The control panel is floor standing suitable for outdoor use.

### Specification

- 415V AC transformers
- Fuse protection for control circuit
- Thermostat controller
- Anti condensation heater
- Door mounted potentiometer
- Hand/Auto selector switch
- Pot/4-20mA selector switch
- 4-2mA input terminals
- Start/stop push buttons
- Running LED indicator
- Door safety micro switch
- Pad-lockable door clasps
- IP54 Zintex steel enclosure
- Load break door interlocked 63A MCCB
- Frame, enclosure and lifting facility
- Main contactor
- Emergency stop facility (Cat0)
- Intake filter and exhaust top box
- Door mounted keypad
- 22kW VLT Aqua drive VSD
- 24vac control circuit
- 110vac control circuit
- Provision for ultra-sonic input
- Stud terminals for motor connection
- Steel document holder for drawings and manual

### Dimensions

- Height: 1400mm
- Width: 800mm
- Depth: 400mm
- Weight: 120kg



## VFD Starter Panel 75kW - Pump FLC 145A

The Variable Speed Drive multifunctional control panel for motors rated up to 75kW. The control panel is floor standing suitable for outdoor use.

### Specification

- 415V AC transformers
- Fuse protection for control circuit
- Thermostat controller
- Anti condensation heater
- Hand/Auto selector switch
- 4-20mA selector
- 4-2mA input terminals
- Start/stop push button
- Running LED indicator
- Door safety micro switch
- Pad-lockable door clasps
- IP54 Zintex steel enclosure
- Load break door interlocked 250A S/FUSE
- Frame, enclosure and lifting facility
- Emergency stop facility (Cat0)
- Door mounted keypad
- 110vac control circuit
- Provision for ultra-sonic input
- Stud terminals for motor connection
- I/S barrier for float switches

### Dimensions

- Height: 1830mm
- Width: 700mm
- Depth: 600mm
- Weight: 205kg



## VFD Starter Panel 90kW - Pump FLC 169A

The Variable Speed Drive multifunctional control panel for motors rated up to 90kW. The control panel is floor standing suitable for outdoor use.

### Specification

- 415V AC transformers
- Fuse protection for control circuit
- Thermostat controller
- Anti condensation heater
- Hand/Auto selector switch
- 4-20mA selector
- 4-2mA input terminals
- Start/stop push button
- Running LED indicator
- Door safety micro switch
- Pad-lockable door clasps
- IP54 Zintex steel enclosure
- Load break door interlocked 250A S/FUSE
- Frame, enclosure and lifting facility
- Emergency stop facility (Cat0)
- Door mounted keypad
- 110vac control circuit
- Provision for ultra-sonic input
- Stud terminals for motor connection
- I/S barrier for float switches

### Dimensions

- Height: 1830mm
- Width: 700mm
- Depth: 600mm
- Weight: 230kg



## VFD Starter Panel 30kW-160kW-Pump FLC280A

The Variable Speed Drive multifunctional control panel for motors rated from 30kW and up to and including 160kW. The control panel is floor standing suitable for outdoor use.

### Specification

- Weather proof enclosure to IP65 rating and complete with mounting stand and lifting eye bolts
- Incoming mains isolator
- Line contactor
- ABB 160kW, 415V, 3 phase, 50Hz ACS800 type variable speed drive
- Mains and motor terminals
- Telemetry control terminals
- Remote control terminals
- Door mounted indication lamps
- Door mounted VSD keypad
- Door mounted start, stop, reset and E Stop pushbuttons
- E stop to category 0
- Hand/off/auto selector switch

### Dimensions

- Height: 1800mm
- Width: 800mm
- Depth: 600mm
- Weight: 400kg



## VFD Starter Panel 250kW

The Variable Speed Drive multifunctional control panel for motors rated from 30kW and up to and including 250kW. The control panel is floor standing suitable for outdoor use.

### Specification

- IP65 floor standing enclosure finished to RAL 2000 yellow orange
- Lifting hooks
- Rain canopy
- Door interlocked isolator
- Max motors size 430A FLC
- ABB 250kW, 415V, 3 phase, 50Hz Variable Speed Drive
- 4-20mA output
- Load break door interlocked isolator
- Main contactor
- Door mounted start, stop, reset and E Stop pushbuttons
- Door mounted keypad
- Door mounted indication lamps
- Earth leakage protection
- Local hand off auto remote selector switch
- Klixon protection
- IS barrier for float circuit
- Fuse protection for control circuits
- 415v~110v control transformer
- Output terminals for motor connections
- I/O wired to terminals
- Floats wired to terminals
- Telemetry connections wired to terminals
- Alarm signals wired to Terminals
  1. Drive ready
  2. Drive tripped
  3. Drive running
  4. High level

### Dimensions

- Height: 1900mm
- Width: 940mm
- Depth: 750mm
- Weight: 320kg



## Godwin

Godwin Pumps one of our own market leading brands, has over 100 years of experience in the design, manufacture, and supply of diesel pumps.

Godwin Pumps is renowned for quality, reliability, and long life.

Today, the product range is used throughout the world, in construction, industry, oil refineries, chemical plants, mines, specialist offshore pumping, irrigation and water distribution.

Our Rental division offers Godwin's range of automatic self-priming pumps with an additional and wider range of Diesel driven Dri-Prime® pumps. The Godwin pumps can be skid or trailer mounted for use in mobile applications which can provide exceptional energy efficiency and a significantly reduced clogging capability.

### Godwin CD series

The Godwin CD range is ideal for high volume, medium head pumping and is capable of handling large solids.

### Godwin HL series

The Godwin HL range is ideal for medium volume, high head pumping and is also capable of handling large solids-handling.

Godwin CD, HL, Heidra and NC series pumps are available to rent from Xylem. All models are available trailer mounted for safe on site transportation or with a skid base. Cast Iron pump end construction, and sound attenuated enclosures.



## Godwin NC series

The range of Godwin NC pumps are not only reliable, they come equipped with the non-clogging, performance of the proven Flygt N-technology.



This breakthrough combination gives you a best-in-class portable pump that delivers sustained hydraulic efficiency to handle tough wastewater pumping applications.

### Self-cleaning Flygt N-technology saves costs

The high efficiency of Flygt N-technology is sustained over time due to its self-cleaning ability, keeping energy/fuel costs to a minimum.

Without a doubt, no matter what the challenge, you will always have the peace of mind knowing that our Godwin NC Series Dri-Prime® pumps are on the job.

### Godwin pumps, now with sustained high efficiency N hydraulics

- Self-cleaning reliability
- Hydraulic efficiency
- Non-stop optimum performance
- Long term energy/fuel savings
- Optimized operating speed for low energy/fuel consumption
- Low downtime
- Extended service intervals
- Minimum maintenance
- Service friendly

## Godwin CD series

### CD100S Dri-Prime®

The Godwin CD100S Dri-Prime pump is a general purpose dewatering pump designed for use in the most challenging construction, municipal, industrial and emergency response applications.

The CD100S is a member of the Godwin S Series of Smart pumps, equipped with a new generation of Field Smart Technology (FST) for remote monitoring and control. In addition to improved hydraulic efficiency, greater fuel economy, and streamlined serviceability, the CD100S impeller is interchangeable with a Flygt N-Technology non-clog impeller, providing the flexibility to tackle stringy, modern wastewater applications with the same pump.

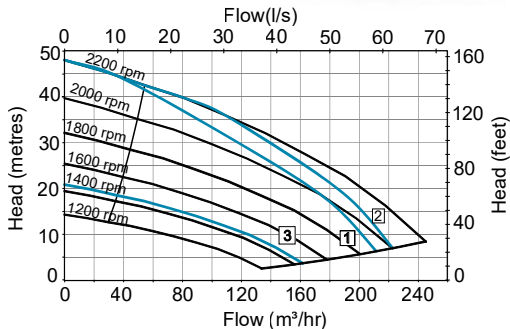

### Overall dimensions

- Length: 1800mm
- Width: 930mm
- Height: 1390mm

### Specifications

- Suction connection: 100mm
- Delivery connection: 100mm
- Max capacity: 245m³/hr\*
- Max head: 20m
- Max impeller diameter: 254mm

### Engine options

1. Perkins 403J-17
2. Perkins 403D-15
3. Electric Motor, 4 Pole, 50Hz

- Max solids handling: 45mm
- Max pressure: 4.7bar
- Max suction pressure: 4.0bar
- Max casing pressure: 7.1bar
- Max operating speed: 2200rpm

\*Larger diameter pipes may be required for maximum flows.

## Godwin CD series

### CD150S Dri-Prime®

The Godwin CD150S Dri-Prime pump is a general purpose dewatering pump designed for use in the most challenging construction, municipal, industrial and emergency response applications.

The CD150S is a member of the Godwin S Series of Smart pumps, equipped with a new generation of Field Smart Technology (FST) for remote monitoring and control. In addition to improved hydraulic efficiency, greater fuel economy, and streamlined serviceability, the CD150S impeller is interchangeable with a Flygt N-Technology non-clog impeller, providing the flexibility to tackle stringy, modern wastewater applications with the same pump.

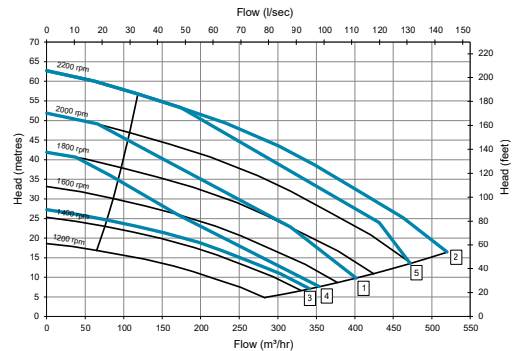

### Overall dimensions

- Length: 1800mm
- Width: 1000mm
- Height: 1900mm

### Specifications

- Suction connection: 150mm
- Delivery connection: 150mm
- Max capacity: 520m³/hr\*
- Max head: 25m
- Max impeller diameter: 301mm

### Engine options

1. Hatz 3H50TICD
2. Perkins 403J-E17T
3. Perkins 404D-22T
4. Electric

- Max solids handling: 75mm
- Max pressure: 6.3bar
- Max suction pressure: 4.0bar
- Max casing pressure: 9.5bar
- Max operating speed: 2200rpm

\*Larger diameter pipes may be required for maximum flows.

## Godwin NC series

### NC100S Dri-Prime®

The Godwin NC100S Dri-Prime pump is designed for use in municipal wastewater applications that contain stringy, modern waste. This unique self-cleaning, non-clog pump is recommended for sewer, lift station, and bypass applications, and is ideal for permanent installations where reliability is absolutely critical, e.g. Diesel Backup Systems (DBS).

The NC100S is a member of the Godwin S Series of Smart pumps, which feature greater fuel economy, easier operation, and reduced maintenance. In addition, the Flygt N-Technology non-clog (NC) impeller is interchangeable with the CD impeller, providing the flexibility to tackle general dewatering applications with the same pump. The Field Smart Technology (FST) is standard on every S series pump, providing real-time remote monitoring and control.

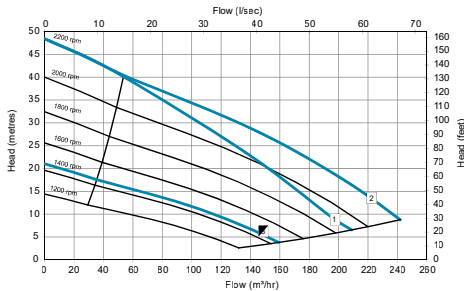

### Overall dimensions

- Length: 1800mm
- Width: 930mm
- Height: 1390mm

### Engine options

1. Perkins 403J-17
2. Perkins 404D-22T
3. Electric Motor, 4 Pole, 50Hz

### Specifications

- Suction connection: 100mm
- Delivery connection: 100mm
- Max capacity: 245m³/hr\*
- Max head: 19m
- Max impeller diameter: 254mm
- Max pressure: 4.7bar
- Max suction pressure: 4.0bar
- Max casing pressure: 7.1bar
- Max operating speed: 2200rpm

\*Larger diameter pipes may be required for maximum flows.

## Godwin NC series

### NC150S Dri-Prime®

The Godwin NC150S Dri-Prime pump is designed for use in municipal wastewater applications that contain stringy, modern waste. This unique self-cleaning, non-clog pump is recommended for sewer, lift station, and bypass applications, and is ideal for permanent installations where reliability is absolutely critical, e.g. Diesel Backup Systems (DBS).

The NC150S is a member of the Godwin S Series of Smart pumps, which feature greater fuel economy, easier operation, and reduced maintenance. In addition, the Flygt N-Technology non-clog (NC) impeller is interchangeable with the CD impeller, providing the flexibility to tackle general dewatering applications with the same pump.



The Field Smart Technology is standard on every S series pump, providing real-time remote monitoring and control.

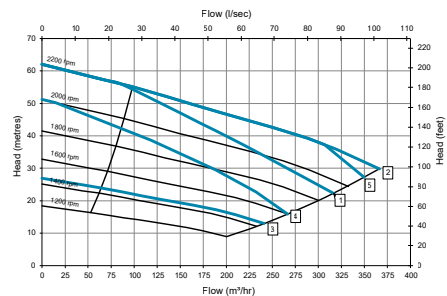

### Overall dimensions

- Length: 2460mm
- Width: 1045mm
- Height: 1743mm

### Engine options

1. Perkins 404D-22T
2. Perkins 1104D-44TA
3. Electric motor
4. Perkins 403J-E17T
5. Perkins 404J-E22TA

### Specifications

- Suction connection: 150mm
- Delivery connection: 150mm
- Max capacity: 366.7m³/hr\*
- Max head: 30m
- Max impeller diameter: 286mm
- Max Allowable Working Pressure (MAWP): 6.1bar
- Max pressure: 6.3bar
- Max suction pressure: 4.0bar
- Max operating speed: 2200rpm

\*Larger diameter pipes may be required for maximum flows.

# Water Treatment

Our treatment rental division has a vast range of treatment products available for short term or semi-permanent treatment requirements in the event of compliance failure, short term outages or planned maintenance work. Xylem has the technology available to ensure you maintain consent whatever your needs.

Our range incorporates a number of the premium Xylem brands with market leading technology in both water and wastewater treatment combined with our nationwide service centres and 24/7 call out make Xylem truly a one-stop shop for both transport and treatment of both water and wastewater.



# Dissolved Air Flotation

Dissolved Air Flotation (DAF) is a proven, effective physical and chemical process for treating various industrial and municipal processes and wastewater.

Xylem RT Rental DAF systems are designed to efficiently remove Total Suspended Solids (TSS), Biochemical Oxygen Demand (BOD), and Fats, Oils and Greases (FOG) from wastewater streams.



**DAF systems are commonly used to meet a variety of treatment goals:**

- Thickening of biosolids
- Product recovery from wastewater
- Treatment of industrial wastewater to meet site discharge limits
- Polishing of biological treatment effluent (algae and phosphorous removal)
- Pretreatment to reduce loading on downstream biological treatment systems
- Clarification of bio-solids, downstream of aerobic and anaerobic treatment
- Removal of fat, oil and grease
- Removal of metals and fines

**In Xylem rental fleet 3 models are available**

Model	Min. Flow (m <sup>3</sup> /hour)	Max. Flow (m <sup>3</sup> /hour)	Size (L/W – mm)
RT-50	20	45*	5020/2190
RT-100	45	90*	6400/2580
RT-240	110	295*	10382/3200

\*Actual results may vary, depending on water temperature, chemistry, chlorides, and solids loading.

## Taron Activated Sludge Filter

Able to handle high solids content fed directly from a secondary activated sludge basin, the Taron filter can relieve the hydraulic and suspended solids load on your secondary clarifiers within a small footprint.



## Taron Activated Sludge Filter

The Taron filter works in parallel with secondary clarifiers to help WWTPs handle permanent or seasonal increases in flow rates, as well as peak flow events.

The system's modular, scalable design and flexible installation options allow simple integration into existing activated sludge treatment processes or use in greenfield facilities. The Taron filter can be installed inside the biological treatment tank, or as a bolt-on solution housed in an external tank in parallel with existing clarifiers.

The Taron unit arrives on-site fully configured, requiring minimal civil works, no excavation, and no interruption of the treatment process.

Taron Filter model*	# of disks	Active filtration surface [m <sup>2</sup> ]	Active filtration surface [ft <sup>2</sup> ]	ADF Flux Rate [gal / hr]
2202	2	6.5	70	845
2203	3	10	108	1300
2204	4	13	140	1690
2205	5	16	172	2080
2206	6	19	204	2470
2208	8	26	280	3380
2210	10	32	344	4160
2212	12	39	420	5070

## Wedeco Spektron

### Wedeco Spektron - Clean Water

The Wedeco Spektron shines new light on the environmentally friendly process of using UV disinfection for drinking water. Featuring highly efficient UV lamp technology and advanced flow distribution, the Spektron series suits modern drinking water treatment plants and covers a wide array of applications from domestic water supply and industrial uses to large municipal water plants with a capacity of more than one thousand m<sup>3</sup>/h per unit.



Xylem has Wedeco Spektron UV reactors available to rent together with their own control panel for ease of use and inspection. The Spektron range can be used in a number of applications where water treatment is needed.

#### Clean Water Applications

Description	kW	Voltage	Max. flow rate m <sup>3</sup> /h
UV Spektron 250e-EW Skid 4 x 290w ECORAY® VLR30 UV lamps Dimensions: 2500 L x 700 W x 1750 H Weight: 330Kg	1.5	230/1/50	377
UV Spektron 650e-EW Skid 8 x 290w ECORAY® VLR30 UV lamps Dimensions: 2900 L x 900 W x 1880 H Weight: 620Kg	3	400/3/50	846
UV Spektron 900e Skid 12 x 290w ECORAY® VLR30 UV lamps Dimensions: 2900 L x 900 W x 1880 H Weight: 620Kg	4	400/3/50	1,037

## Wedeco Containerised LBX 850e UV Treatment

### LBX 850e Containerised UV Rig - Wastewater

The LBX reactor is a compact wastewater UV disinfection system suitable for low UV transmissivity applications. The reactor includes high efficiency low pressure Ecoray UV lamps and includes its own dedicated smart dose controller including SCADA connection. Housed in a dedicated enclosure for ease of installation and transport the unit is a self-contained UV disinfection solution for wastewater applications.



- Container size: standard 20 Foot ISO shipping container – 6.05m L, 2.44m W, 2.59m H
- Container weight: 3,800Kg - Dry
- Inlet connection: DN400 PN16
- Outlet connection: DN400 PN16
- Electrical supply: TP&N – 40A (400/3/50)
- Lamps: 32 x 285W Ecoray lamps
- Total load in kW drawn by panel & lamps: 13kW
- Max flow rate: 1,356 m<sup>3</sup>/h



## Flygt Mixers

Flygt submersible mixers consist of a drive unit and propeller, integrated into a compact unit. The mixer is mounted on a guide bar, to enable it to be raised and lowered, to operate at different depths. It can also be angled upwards or downward and can be swivelled to the sides. Its mixing action can therefore be directed to any point in a lagoon or tank.

This flexibility aided by the large blade propeller, running at relatively low speeds, sets in motion large volumes of sludge and water. The Flygt submersible mixer is at least three times as efficient as a conventional mixer. This is due to the high efficiency hydraulic design and the fact that the motor and propeller are integrated into a lightweight, compact unit. No energy is lost in complicated gearing, support bearings and heavy shafts. Also, the mixer can be run intermittently, thus providing further energy savings.

### Compact design

The machines are either direct-driven or include a reduction gearbox between the motor and the propeller. However, all models are well integrated into a compact unit. So no energy is lost in long heavy shafts and support bearings.

### Circular tanks

One mixer is normally sufficient for tank volumes up to 2,000m<sup>3</sup>. Depending on the characteristics of the liquid and the desired degree of agitation, more than one mixer may be necessary for larger tank volumes.

### Rectangular tanks

If the length, width and depth dimensions of the tank differ considerably, several mixers may be necessary to ensure good results. Rectangular tanks are often located underground. Since Flygt mixers are installed from the top, installation in underground tanks is easy.

For specific duties on the range of Flygt submersible mixers please contact your local service centre.

## Flygt Mixers in Practice

### Homogeneous liquid manure in a couple of hours

Flygt submersible mixers have an important role to play in agriculture, for homogenising liquid manure. Even if the manure is old, with a thick dry crust and all the solids have settled at the bottom of the tank, it will be possible by mixing for the whole tank contents to become homogeneous. This is due to the fact that the mixer can operate at different depths, can be orientated in any direction and will quickly set in motion large volumes of the manure.

### Wide field of applications in industry

Flygt submersible mixers are used for keeping liquids of different viscosities in suspension, for mixing dry solids into liquids, for thickening after sedimenting and decanting, and for transporting liquids.

### Good environment in fish farming

Whether in netting enclosures in open water or in dammed bays, Flygt submersible mixers will maintain ideal fish farming conditions at a modest cost. The mixer will supply a briskly-flowing current of fresh water with good oxygen contents and an abundance of natural food. At the same time, fish droppings will be removed. The risk of rotting and formation of decay gases is eliminated. By establishing circulation between the bottom and the surface, the mixer also evens out the water temperature, which favours the growth of the fish.

### Improving the efficiency in sewage treatment plants

Flygt submersible mixers have been widely adopted in sewage treatment plants throughout the world. Particularly in thickening, sludge and storm water ponds, in buffer tanks and in the mixing of chemicals and lime into the water, the efficiency and low operating costs of the mixers can be utilised to the greatest possible extent.

### Flow creation

For low head, high capacity laminar flows the large propeller mixer can be used in lake reservoirs, fish farms as well as process mixing.

# Flygt Mixers

As shown:

4620 1.5kW mixer fitted on a portable, free standing steelwork - available to rent.



# Available Flygt Mixers

Type	A Max ø mm	B Max ø mm	C mm	D mm	E mm	F mm	G mm	H mm	I mm	Weights (max) kg (lbs)
4410	2500	-	-	-	-	-	1110	1010	100	230 (507)
4430	2500	-	-	-	-	-	1110	1010	100	263 (580)
4630	390	636	405	559	469	117	574	457	50	61(134)
4640	390	636	405	559	509	117	614	497	50	64(141)
4650	650	1027	675	931	721	195	878	700	100	177 (390)
4660	650	1027	675	931	831	195	988	810	100	218 (481)
4670	880	1372	908	1256	835	264	992	816	100	363 (800)
4680	880	1372	908	1256	985	264	1192	966	100/150	482 (1063)

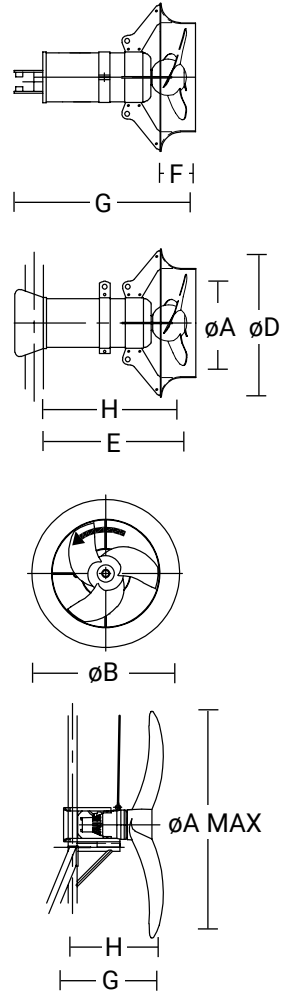

## Aeration - Flygt Radial Aerators

### Fields of application

The efficient mixing characteristics and the simple design of our ejectors and aerators make them suitable for aerating biological ponds, fishfarm ponds, lakes and waterways.

### The function of the ejectors

The principle on which the ejector operates is simple and well-known. A drive jet from a Flygt submersible pump is led into the ejector. The drive jet flows through a nozzle into the ejector housing, which has a delivery pipe for the medium, e.g. air, which is to be pumped (the secondary flow). A drop in pressure occurs when the drive jet passes through the mixing tube. This partial vacuum automatically entrains the pump medium with the drive jet and the contents of the primary and secondary flows are mixed intensively with each other.

### The function of the radial aerator

Aeration by means of high efficiency mixing. Air dispersion by the same method as the ejector is distributed radially within a tank, basin or lagoon, via the series of diffusers mounted around a central turbine impeller. As with the ejectors, being totally submerged significant advantages arise over other forms of aeration.

### Low noise levels

No sprays or liquid dispersion in the atmosphere.

### Installation

Installation of these aeration products is straightforward either by bolting to the tank floor or they even will be suspended by their own weight in certain circumstances.

### Applications

Subject to the tank configuration the ejector or aerator can be selected to:

- Replace existing aeration equipment during breakdown or maintenance periods.
- Upgrade existing treatment capacity without major investment. Increase oxygen levels. Reduce ammonia levels.



## Dimensions and Weight - Flygt Radial Aerators

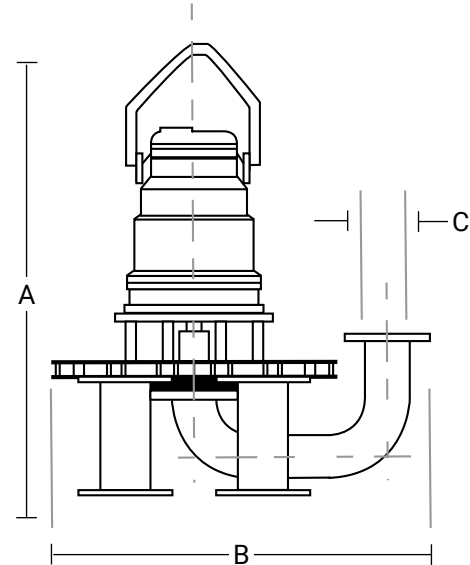

Type	Power	Current	Dimensions (mm)			Weight kg*
			a	b	c	
308	2.4	4.5	610	660	50	75
310	4.4	8.5	700	660	50	105
312	5.9	11.0	800	950	80	180
315	13.5	25.0	1130	995	100	295
320	22	42.0	1320	1150	150	500

\* Weight includes 10m of cable

## Flygt Radial Aerators - Oxygen Transfer Rate

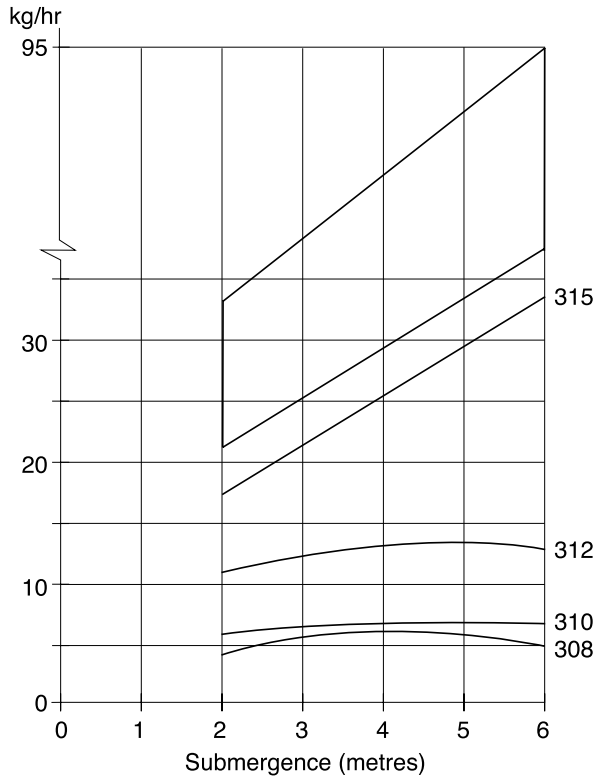

## Flygt Flyjet

Utilising the principles of an ejector; the Flyjet can be used to resuspend solids which have settled in storage tanks.

They can be used in storm water retention tanks at sewage works; for example, 4" and 6" jet pipes are available.



## Pump Flotation Modules

### The concept

Our range of pump flotation modules has been developed to provide a light-weight and cost-effective alternative to the traditional steel pontoon. The flotation modules are prefabricated from light-weight, foam-filled, GRP (Glass fibre Reinforced Polymer) and are available in four sizes.

### General applications

Pump flotation modules can be supplied to suit Flygt 2000 Series / BS dewatering pumps, C/N-series wastewater pumps and slurry pumps.

#### Applications include:

- Mine dewatering
- Tailing dams
- Underground dams
- Sewage treatment
- Quarries
- Aeration ponds
- Construction site dewatering
- Flooding control

### Installation

The pump and integral module can be simply installed by use of a central lifting attachment. Once in the water, the module can be towed by boat, if required, and secured in position by anchor or guy ropes. The float module remains visible above the water surface for easy recovery.

#### Design features:

- Compact and lightweight
- Stainless steel metal parts
- Easily mounted to pumps on site
- Lifting points for easy installation
- Easy to transport as an integral unit
- Foam filled to prevent sinking

By having the pump floating close to the surface, it increases service life through reduced maintenance since it is no longer working within high solids environment.

### PFM550

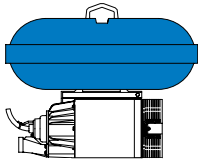

1400 x 1400 x 540mm  
20kg

PFM 550	Part Number
2201	691 69 00
3140	*
3152/3153	*
3170/3171	*
5100 (<52kW)	*
5150 (<52kW)	*

\* On request

## Hoses and Fittings

To complement our comprehensive range of pumps, extensive stocks of pipework and hoses are held. Our rental engineers can supply all your needs from 50mm hose increasing in size to steel pipes in excess of 450mm.

Also BSP pipe and cast iron fittings to suit most applications including valve, taper, hose spigot, flexible couplings and hose clamps, specialised hoses for high pressure applications are also stocked.

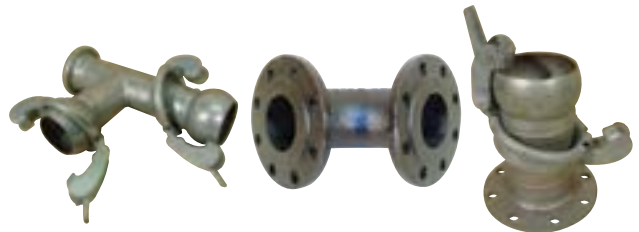
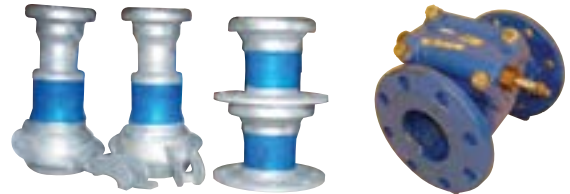

## Hoses and Fittings

A pump relies on a secure link between the source and the discharge point. Poor hoses will leak, collapse and cause unwanted problems. So, at Xylem we only sell those hoses we use ourselves – “Cheap hose is expensive hose in the long run”.

### Wire-armoured suction hose



Bore dia. mm	Outside dia. mm	Working pressure bars	Weight per 6m incl. cpgs kg
51	63	8	12
76	89	8	26
102	116	8	35
150	169	5	60

A tough hose developed for the construction industry, with a tube of smooth synthetic rubber, covered with weather resistant synthetic rubber, reinforced with cords of synthetic textile and an embedded helix of high-tensile steel wire. It is flexible and heavy, yet easy enough to manoeuvre. It seals well onto the pipe fittings, withstands high pressure and is also tough. It is ideal for suctions and for discharge where the bend must not collapse.

### PVC suction and discharge hose



Bore dia. mm	in.	Outside dia. mm	Working pressure bars	Weight per 6m incl. cpgs kg
50	2	58	5	6
75	3	87	5.5	10
100	4	115	4.5	25
150	6	167	3	40

PVC is a high grade hose, flexible, lightweight, with exceptional resistance to abrasion and weathering. The smooth bore offers minimum resistance to flow. The strengthened PVC helix is embedded in the hose wall for extra strength.

### Polythene delivery hose



Bore dia. mm	in.	Outside dia. mm	in.	Working pressure bars	psi	Weight per 6m incl. cpgs kg
50	2	65	2.5	6	90	8
75	3	90	3.5	4	60	14
100	4	115	4.5	3	50	18
150	6	170	6.75	3	50	43

This is a proven semi-rigid delivery hose, which is well known throughout the industry. It is damage resistant, but also lightweight and simple to handle. Friction loss is kept to a minimum in this smooth bore hose.

## Friction Loss in Pipe Fittings Chart

### Friction loss in smooth bore pipe

#### Losses in m/100 or ft./100ft

I.G.P.M.	2"	3"	4"	6"	8"	10"	12"	m <sup>3</sup> /h
50	10	1.4	0.3					10
75	20	3	0.7					15
100	35	5	1	0.1				20
150		12	2.5	0.35				30
200		18	4.5	0.6				50
300		40	10	1.2	0.4			75
400			18	2.2	0.7			100
500			28	3.5	1.1	0.35		125
600			38	4.5	1.5	0.5		150
700				6.5	2	0.7		175
800				8	2.7	0.8		200
900				10	3.4	1	0.4	225
1000				13	4	1.4	0.5	250
1200				18	6	2	0.8	300
1400				26	8	3	1	350
1600				32	11	4	1.5	400
1800				36	14	4.5	2	450
2000				38	17	5	2.5	500
2500					25	9	4	650
3000					38	12	5	750
4000						21	8	1000
5000						32	13	1250

m<sup>3</sup>/h x 4 = g.p.m. approx

The table refers to new pipes and moderate corrosion could increase resistance by 30%. To calculate resistance of bends and fittings, an 'equivalent length' for each accessory needs to be added to the actual length of pipe. The equivalent length in feet can be estimated by multiplying the factors in the adjacent table by the pipe diameter in inches.

Example :- A 6" Gate Valve is equivalent to 12 ft of extra pipe

Mitre elbow or tee	5
Round elbow	3
Slowbend	2
Square edged entrance	3
Gate valve fully open	2
Globe valve fully open	10
Non-return valve (flap type)	3
Foot-valve and strainer (clean)	5

## Weight Reference Guide - Pumps and Starters

Pump Type	BS/NS Weight Inc. Base Stand	Pump Type	Weight
2052	18kgs	<b>Large Submersible Pump Range</b>	
2066	30kgs	3231 85Kw	1,380kgs-Pump Only
2102	50kgs	3231 105Kw	1,590kgs-Pump Only
2125 Aluminium	89kgs	3231 125Kw	1,530kgs-Pump Only
2125 Cast Iron	180kgs	3231 170Kw	1,760kgs-Pump Only
2151	165kgs	3231 215Kw	1,910kgs-Pump Only
2201MT Aluminium	280kgs	3312 100Kw	1,975kgs-Pump Only
2201MT Cast Iron	445kgs	3312 180Kw	2,275kgs-Pump Only
2201HT Aluminium	240kgs	3312 250Kw	3,125kgs-Pump Only
2201HT Cast Iron	350kgs	3356 100Kw	1,750kgs-Pump Only
2250	540kgs	3400 75Kw	2,700kgs-Pump Only
2400	985kgs	3400 250Kw	3,750kgs-Pump Only
2610 MT	21kgs	3501 125Kw	4,000kgs-Pump Only
2620 MT	32kgs	<b>Godwin Diesel Range (Sound attenuated enclosure)</b>	
2640 MT & HT	51kgs	CD100S Dri-Prime® Pump	1,325kgs
2660 MT & HT	78kgs	CD150S Dri-Prime® Pump	1,650kgs
2670 MT & HT	141kgs	NC100S Dri-Prime® Pump	1,510kgs
3085MT	71kgs	NC150S Dri-Prime® Pump Perkins 404D-22T	1,480kgs
3102MT	116kgs	NC150S Dri-Prime® Pump Perkins 404J-E22TA	1,725kgs
3102SH	114kgs	<b>Mixers</b>	
3127MT	170kgs	4620	18kgs
3127HT	155kgs	4630	60kgs
3152LT	426kgs	4640	63kgs
3152MT	321kgs	4650	174kgs
3152HT	280kgs	4660	209kgs
3153 LT	379kgs	4670	345kgs
3153MT	252kgs	<b>Starters</b>	
3153HT	232kgs	15kW Soft Start	30kgs
3153SH	242kgs	90kW Soft Start	160kgs
Concertor 5.5kW 150mm	130kgs	22kW VFD	120kgs
Concertor 7.3kW 100mm	112kgs	75kW VFD	205kgs
3171LT	460kgs	90kW VFD	230kgs
3171MT	362kgs	160kW VFD	400kgs
3171HT	321kgs	<b>Treatment Plant</b>	
3201MT	588kgs	LBX850 UV Plant-20' Container-Dry Wight	3,800kgs Approx.
3201HT	540kgs	Spektron 250e UV-Skid-Dry Weight	330kgs Approx.
3202LT	900kgs	Spektron 650e UV-Skid-Dry Weight	620kgs Approx.
3202MT	610kgs	Spektron 900e UV-Skid-Dry Weight	620kgs Approx.
3202HT	580kgs	SAF Plant 20' Container-Dry Weight	9,500kgs Approx.
3300LT	1,175kgs		
3300MT	1,188kgs		
3300HT	988kgs		
3301LT	1,110kgs		
3301MT	1,030kgs		
3301HT	920kgs		
3315LT 62kW	1,530kgs		
3315LT 90kW	1,330kgs		
3315HT 105kW	1,220kgs		

The weights contained within this guide are an estimate only and the actual weight of the item to be lifted must be separately assessed and verified.

The weights above DO NOT include Cable, Chains or Hoses

The Information contained within this document is for guidance only and is accurate to the best of our knowledge at time of going to print.

## Weight Reference Guide - Accessories

	Size (M)	2'-50mm kg	3'-80mm kg	4'-100mm kg	6'-150mm kg	8'-200mm kg	10'-250mm kg	12'-300mm kg
<b>Cast Iron Pipe &amp; Fittings</b>								
Gate Valve Metal Wedge	17	23	35	65	104	170	228	
NRV Cast Iron Flap Type	12	16	21	37	69	132	187	
D/F Bend Short	11	13	22	34	55	77	101	
D/F Bend Long	16	21	34	52	74	101	116	
Duck Foot Bend	15	19	33	50	82	115	116	
Equal Tee	17	21	36	54	87	121	164	
Radial Tee	17	20	36	54	89	127	177	
"Y" Piece	8	10	15	22	33	46	66	
Taper	4	5	7	11	15	20	28	
V/JFA	16	20	30	40	52	66	84	
Cast Iron Pipe Cement lined kg/M.No Flanges	16	20	30	40	52	66	84	
NP 16 Flange	5	6	8	10	15	20	28	
<b>Hoses:</b>								
Wire Armoured Hose C/W Bauers	6	12	26	35				
PVC Suction & Discharge Hose C/W Bauers	6	6	10	25				
Polythene Semi Rigid Hose C/W Bauers	6	8	14	18	43			
Wire Armoured Hose C/W Bauers	3				35	50	95	
Wire Armoured Hose C/W Flanges	3				65	95	125	
<b>Steel "Bauer" Type Pipe &amp; Fittings</b>								
Galvanised pipe	1	3	5	8	15	20		
Galvanised pipe	2	3	7	12	20	30		
Galvanised pipe	3	7	11	16	32	40		
Bauer Ball Connector	0.2	0.3	1	1.5	2			
Bauer Level Closure Ring	0.5	1	1.5	4	6			
Bauer Socket	0.1	0.3	0.6	1.2	2.5			
Bauer 90 Deg Bend C/W Closure Ring	1	2.5	5.5	11	13			
Bauer Equal Tee C/W 2 Closure Rings	1.5	4	8	15	14			
Bauer Flanged with ball & Closure Ring	3	5	8	14	22			
Bauer Flanged with Socket	3	4	4	5	7			

The weights contained within this guide are an estimate only and the actual weight of the item to be lifted must be separately assessed and verified.

## Conversion Factors

Inches	x 25.4	= mm	x 0.0394	= Inches
Feet	x 0.3048	= m	x 3.281	= Feet
Yards	x 0.9144	= m	x 1.0936	= Yards
Miles	x 1.609	= km	x 0.6214	= Miles
Ft <sup>2</sup>	x 0.0929	= m <sup>2</sup>	x 10.764	= Ft <sup>2</sup>
Miles <sup>2</sup>	x 2.59	= km <sup>2</sup>	x 0.3861	= Miles <sup>2</sup>
In <sup>3</sup>	x 16387	= mm <sup>3</sup>	x 0.000061	= In <sup>3</sup>
Ft <sup>3</sup>	x 0.02832	= m <sup>3</sup>	x 35.31	= Ft <sup>3</sup>
Gals (Imp)	x 4.546	= L	x 0.22	= Gals (Imp)
Gals (Imp)	x 0.004546	= m <sup>3</sup>	x 220	= Gals (Imp)
Gals (US)	x 3.785	= L	x 0.2642	= Gals (US)
LBS	x 0.4536	= kg	x 2.2046	= LBS
Tons	x 1016	= kg	x 0.000984	= Tons
Gal/Min (Imp)	x 0.2727	= m <sup>3</sup> /h	x 3.6667	= Gal/Min (Imp)
Gal/Min (Imp)	x 0.0757	= L/Sec	x 13.21	= Gal/Min (Imp)
L/Sec	x 3.6	= m <sup>3</sup> /h	x 0.277	= L/Sec
Gal/Min (Imp)	x 1.2	= USGPM	x 0.833	= Gal/Min (Imp)
PSI	x 0.06895	= Bar	x 14.504	= PSI
PSI	x 0.703 S.G	= M Liquid	x 1.422xS.G	= PSI
Ft Liquid	x 0.02989xS.G	= Bar	x 33.456 SG	= Ft Liquid
STD. ATM	x 1.01225	= Bar	x 0.9879	= STD. ATM
HP	x 0.7457	= kW	x 1.341	= HP

## Conversion Factors

### Flow Conversions

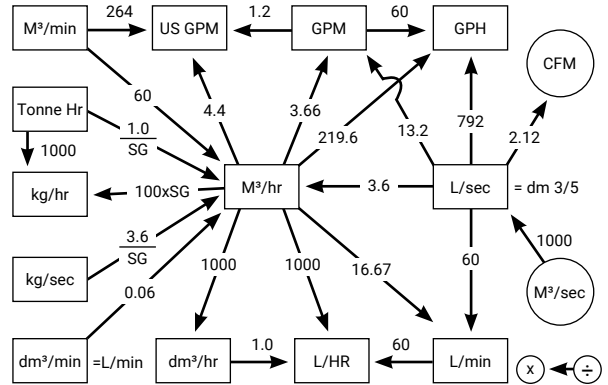

### Head/Pressure Conversions

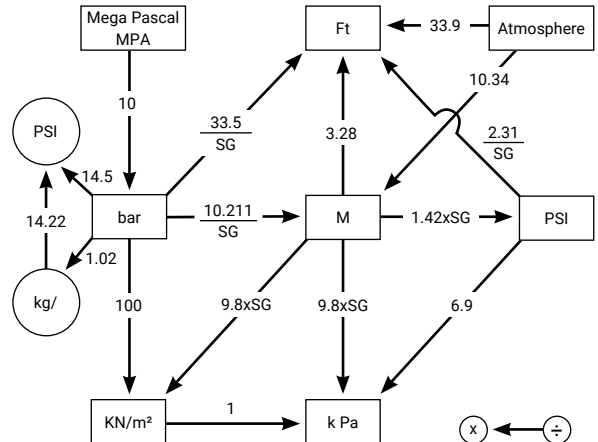

## Flange Sizes

Normal Bore	Table	Dia. Flange	P.C.D	Bolt Dia.	No. of Bolts	Flange Thickness Grey Cast Iron
1"	D&E	4.50"	3.25"	.50"	4	.50"
1.25"	D&E	4.75"	3.44"	.50"	4	.625"
1.5"	D	6.00"	4.50"	.625"	4	.688"
2"	E	6.00"	4.50"	.625"	4	.750"
50mm	NP16	165mm	125mm	M16	4	20mm
2.5"	D	6.50"	5.00"	.625"	4	.688"
	E	6.50"	5.00"	.625"	4	.750"
3"	D&E	7.25"	5.75"	.625"	4	.750"
80mm	NP10	200 (7.87)	160 (6.30)	M16	8	21 (.83)
	NP16	200 (7.87)	160 (6.30)	M16	8	21 (.83)
4"	D	8.50"	7.00"	.625"	4	.750"
	E	8.50"	7.00"	.625"	8	8.75"
100mm	NP10	220 (8.66)	180 (7.09)	M16	8	22 (.87)
	NP16	220 (8.66)	180 (7.09)	M16	8	22 (.87)
5"	D	10.00"	8.25"	.625"	8	.813"
	E	10.00"	8.25"	.625"	8	.875"
6"	D	11.00"	9.25"	.625"	8	.813"
	E	11.00"	9.25"	.750"	8	8.75"
150mm	NP10	285 (11.22)	240 (9.49)	M20	8	23 (.91)
	N16	285 (11.22)	240 (9.49)	M20	8	23 (.91)
7"	D	12.00"	10.25"	.625"	8	.875"
	E	12.00"	10.25"	.750"	8	1.00"
8"	D	13.25"	11.50"	.675"	8	.875"
	E	13.25"	11.50"	.750"	8	1.00"
200mm	NP10	340 (12.38)	295(11.61)	M20	8	245 (.96)
	NP16	340 (12.38)	295(11.61)	M20	12	245 (.96)
9"	D	14.50"	12.75"	.625"	8	.875"
	E	14.50"	12.75"	.750"	12	1.00"
10"	D	16.00"	14.00"	.750"	8	1.00"
	E	16.00"	14.00"	.750"	12	1.00"
250mm	NP10	400 (15.75)	350(13.78)	M20	12	26 (1.02)
	NP16	400 (15.75)	355 (13.98)	M25	12	26 (1.02)
12"	D	18.00"	16.00"	.750"	12	1.00"
	E	18.00"	1.00"	.875"	12	1.125"
300mm	NP10	455 (17.91)	400 (15.75)	M20	12	27.5 (1.08)
	NP16	455 (17.91)	410 (16.14)	M25	12	27.5 (1.08)

NP10 and NP16 are for cold water pressure of 10 bar and 16 bar and are the current British Standard. They are unnecessarily heavy for most contractors' pumps.

## Contact us

### Xylem rental centres



National Call Centre

0845 707 8012



fgb.rental@xylem.com



xylem.com/uk

# Xylem | 'zīlām|

---

Xylem (XYL) is a leading global water technology company committed to solving the world's critical water challenges with innovation and expertise. Our 23,000 diverse employees delivered combined pro forma revenue of \$8.1 billion in 2023. We are creating a more sustainable world by enabling our customers to optimize water and resource management and helping communities in more than 150 countries become water-secure. Join us at [www.xylem.com](http://www.xylem.com) and Let's Solve Water.

---

[xylem.com/uk](http://xylem.com/uk)

Tel 0845 707 8012

© 2025 Xylem Inc. or its affiliate  
reserve the right to make modification  
without prior notice.  
All rights reserved.

**xylem**  
Let's Solve Water