



StirrOx G

DISSOLVED OXYGEN SENSOR WITH INTEGRATED STIRRER



a xylem brand

Copyright © 2018 Xylem Analytics Germany GmbH
Printed in Germany.

StirrOx G - Contents

1	Overview	5
2	Safety instructions	6
3	Commissioning	6
4	Measuring / Operation	7
4.1	Calibration	7
4.2	Measuring	7
4.3	Storage	8
5	Maintenance, cleaning, replacement	8
5.1	General maintenance instructions	8
5.2	Outside cleaning	9
5.3	Changing the electrolyte and membrane cap	9
5.4	Cleaning the electrodes	12
5.5	Checking the sensor for freedom from zero-current	14
5.6	Disposal	14
6	What to do if	15
7	Technical data	15
8	Wear parts and accessories	19

1 Overview

Structure

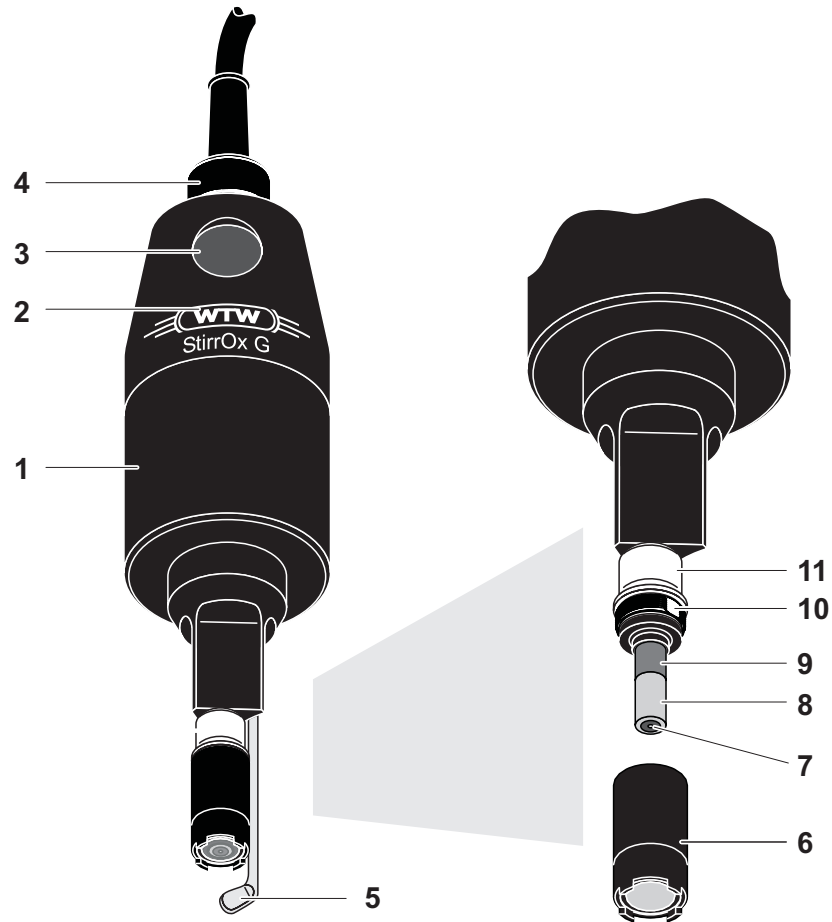

1	Shaft housing
2	Connection head
3	On/Off key for stirrer
4	Cable screw joint
5	Stirring paddle
6	WP-ST membrane cap (filled with electrolyte solution)
7	Gold working electrode (cathode)
8	Insulator
9	Lead counter electrode (anode)
10	Ventilation area
11	Temperature sensor and auxiliary electrode

Recommended application range

BOD measurements in BOD sample bottles.

2 Safety instructions

This operating manual contains special instructions that must be followed during the operation of the D.O. sensor.

Always keep this operating manual in the vicinity of the sensor.

Special user qualifications

The membrane cap of the D.O. sensor is filled with a small amount of an alkaline electrolyte solution. All maintenance work that requires dealing with the electrolyte solution must only be carried out by persons who know how to safely deal with chemicals.

General safety instructions

The individual chapters of this operating manual use safety labels like the one below to indicate danger:



CAUTION

indicates instructions that must be followed precisely in order to avoid slight injuries or damage to the instrument or the environment.

3 Commissioning

Scope of delivery

- D.O. sensor StirrOx G, filled with electrolyte solution and ready to operate
- Calibration and storage vessel, OxiCal[®]-ST
- ZBK-ST accessory kit, comprising:
 - 3 exchange membrane caps, WP-ST
 - Electrolyte solution, ELY/G
 - Cleaning solution, RL/G
 - Polishing strip, SF 300
- Operating manual



The membrane cap that is mounted on the sensor for delivery serves mainly as a transport protection. Depending on the duration of the transport and storage period, it may have a shortened operational lifetime. If the measuring system cannot be calibrated (error message of the instrument), please proceed according to section REPLACING THE ELECTROLYTE SOLUTION AND MEMBRANE CAP.

Getting the sensor ready for measuring

Connect the 8-pin plug to the Oxi input and the 2-pin plug to the stirrer connection of the meter (see operating manual of the meter). The sensor is immediately ready to measure. It is not necessary to polarize the sensor.

4 Measuring / Operation

4.1 Calibration



For calibration, please refer to the operating manual of the measuring instrument.

4.2 Measuring

Depth of immersion

Observe the minimum and maximum depth of immersion of the sensor. The temperature sensor / auxiliary electrode must be completely submerged for measurement.

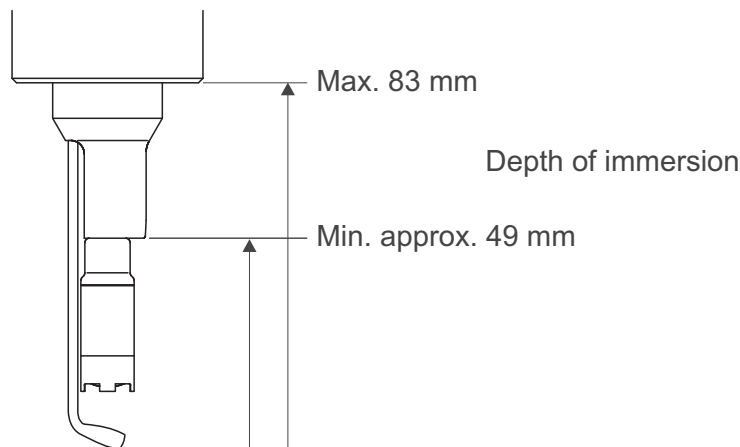

CAUTION

The sensor is designed for immersion measurements in BOD bottles. Do not expose the sensor to overpressure (see chapter 7 TECHNICAL DATA), e.g. due to sealed installation in a pressurized vessel. Danger of damage to the sensor.

Use of the integrated stirrer

The sensor is equipped with an integrated stirring system for the incident flow of the membrane.

Pressing the On/Off key switches the stirrer on. Pressing once more switches the stirrer off again.

Measurement in sample bottles

The displacement volume of the StirrOx G (5,6 ml) is dimensioned so that the sample bottle is closed free of air bubbles after inserting the sealing plug. If you use bottles other than the Karlsruhe bottles available at WTW (see chapter 8 WEAR PARTS AND ACCESSORIES), use WHEATON bottles or bottles with NS 19 standard ground joint only. The plug should have a displacement volume of 5.6 to 8.6 ml.



After each measurement series (before storing the sensor) clean the sensor (exterior cleaning).

4.3 Storage

Always store the sensor in the calibration and storage vessel at a temperature in the range 0 ... +50 °C (32 ... 122 °F). Make sure that the sponge in the calibration and storage vessel is always moist.

Calibration and
storage vessel,
OxiCal®-ST

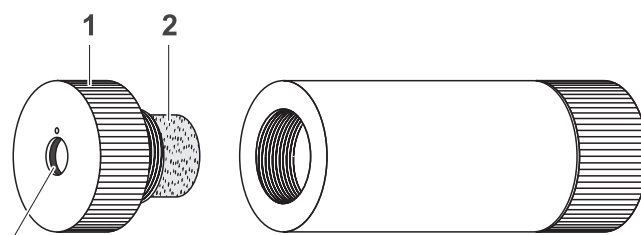

Receptacle
for stand

Moisten the sponge:

- Screw out the insert (1).
- Take out the sponge (2), wet it, then slightly squeeze it out.
- Put in the sponge and screw the insert in the calibration and storage vessel again.

Sta-ST stand

The Sta-ST stand (see chapter 8 WEAR PARTS AND ACCESSORIES) enables you to place the calibration and storage vessel with the sensor in an upright, tilt resistant position on a table.

5 Maintenance, cleaning, replacement

5.1 General maintenance instructions

For your safety

Note the following safety instructions when handling electrolyte and cleaning solutions:



CAUTION

The ELY/G electrolyte solution and RL-G cleaning solution irritate the eyes and skin. Note the following points when dealing with these solutions:

- During working activities, always wear suitable protective gloves and protective goggles/face shield.
- If the solutions come into contact with the skin, rinse thoroughly with water and immediately change contaminated clothing.

- If the solutions come into contact with the eyes, rinse thoroughly with water and consult a doctor.
- Follow the safety datasheet.

**CAUTION**

Before all maintenance activities, disconnect the sensor from the instrument.



Information on how to order wear parts and maintenance equipment can be found in chapter 8 WEAR PARTS AND ACCESSORIES.

Removable stirring paddle

The stirring paddle can be pulled off for maintenance purposes. After finishing the maintenance activities reinsert the stirring paddle into the receptacle as far as it will go. Then turn the stirring paddle so that the paddle face is positioned in center under the membrane cap.

5.2 Outside cleaning**Cleaning agents**

Contamination	Cleaning procedure
Lime sediments	Immerse in acetic acid for 1 minute (volume share = 10 %)
Fat/oil	Clean with warm water that contains washing-up liquid

After cleaning, thoroughly rinse with deionized water and recalibrate if necessary.

5.3 Changing the electrolyte and membrane cap**General information****CAUTION**

Before starting to work with the sensor, please note the **GENERAL MAINTENANCE INSTRUCTIONS** on page 8.

WTW delivers the sensor ready to operate (see section 3). The electrolyte solution and membrane cap must only be replaced if:

- a calibration error occurs and the membrane is heavily contaminated
- the membrane is damaged
- the electrolyte solution is exhausted.
- in case of a leak message by the measuring instrument

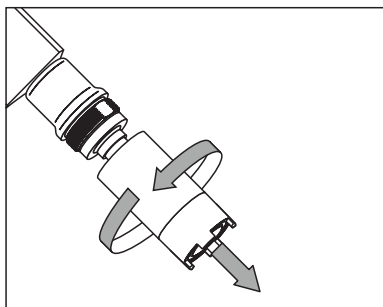
Changing the electrolyte and membrane cap

Pull off the stirring paddle and screw off the membrane head.

Caution: Electrolyte solution!
For disposal of the membrane head and electrolyte solution, see section 5.6.

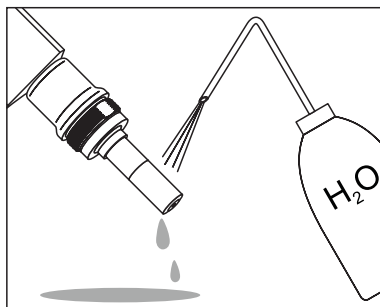

Rinse the sensor head with deionized water.

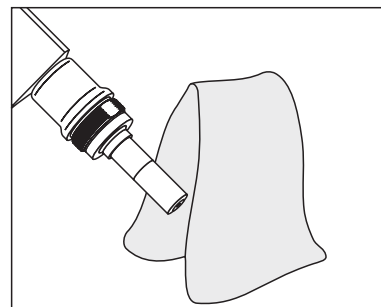

Carefully rub and dry the counter electrode with a lint-free paper towel.

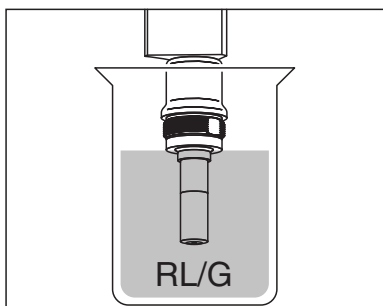

Immerse the sensor head including the counter electrode in RL/G cleaning solution.

Allow to react for 1 to 3 minutes.

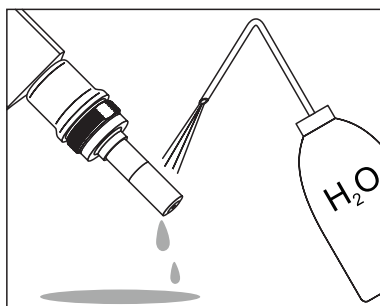

Thoroughly rinse the sensor head with deionized water.

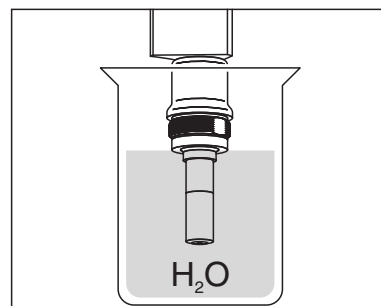

Water the counter electrode in deionized water for at least 10 minutes.

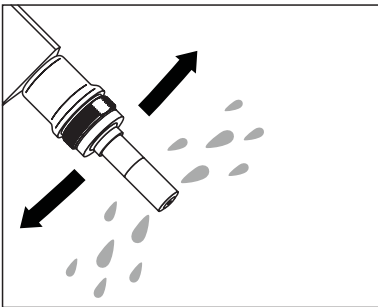

Carefully shake off the drops of water.

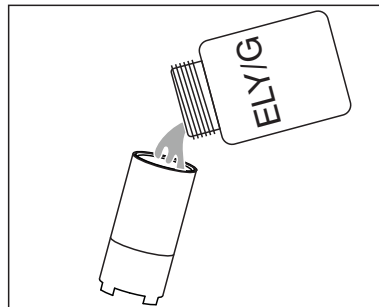

Fill a new membrane cap with ELY/G electrolyte solution.

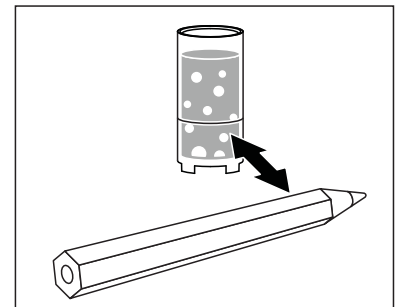

Remove any air bubbles by carefully tapping the membrane cap. Additionally, you can prevent air bubbles by throwing the first filling away and refilling the membrane cap.

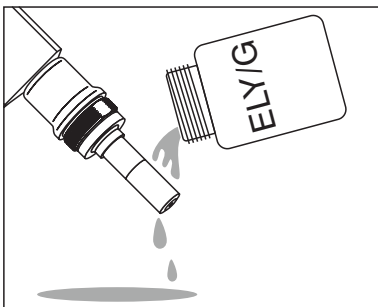

Thoroughly rinse the sensor head with electrolyte solution.

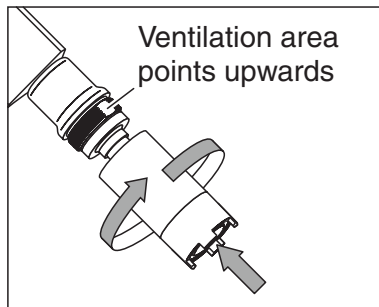

Hold the sensor inclined and screw on the membrane head fingertight using a paper towel. Excess electrolyte solution is forced out of the ventilation area.

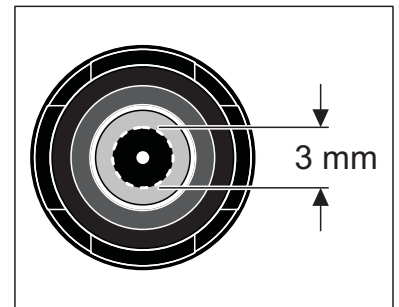

Check the filling: Inspect the face surface. No air bubbles may be present within the dashed circle. Air bubbles outside this area do not interfere.

Readiness to measure

To measure, plug in the stirring paddle. After approx. 30 to 50 minutes, the sensor is ready for operation. Subsequently calibrate the sensor.



If you want to measure very low oxygen concentrations (< 0.5 % saturation), we recommend to let the sensor rest overnight and then calibrate it.

5.4 Cleaning the electrodes



General information

CAUTION

Before starting to work with the sensor, please note the **GENERAL MAINTENANCE INSTRUCTIONS** on page 8.

Cleaning is only required in cases of slopes too low or too high (sensor cannot be calibrated) that cannot be resolved by changing the membrane head and electrolyte solution.

Cleaning the electrodes

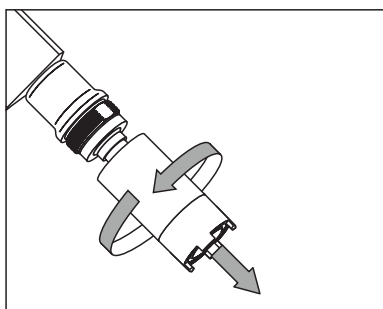

Pull off the stirring paddle and screw off the membrane head.

Caution: Electrolyte solution!
For disposal of the membrane head and electrolyte solution, see section 5.6.

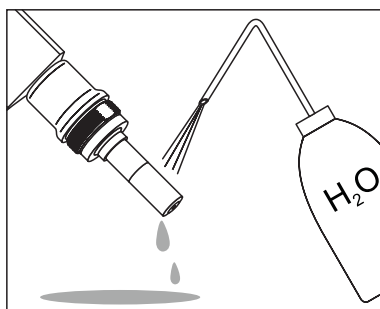

Rinse the sensor head with deionized water.

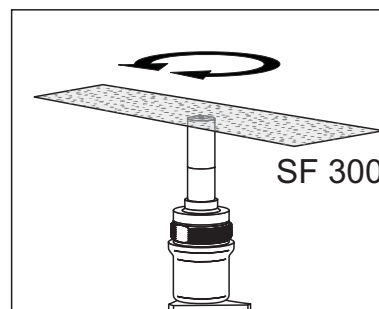

Using the rough side of the **wet SF 300** polishing strip, polish off any contamination from the gold working electrode using light pressure.

Caution: Do not use any conventional sandpaper or glass-fiber brushes.

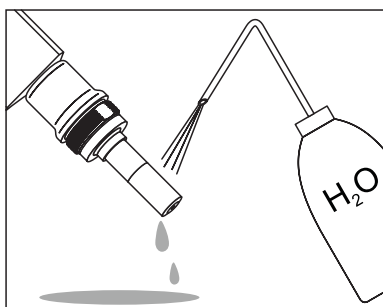

Rinse the sensor head with deionized water.

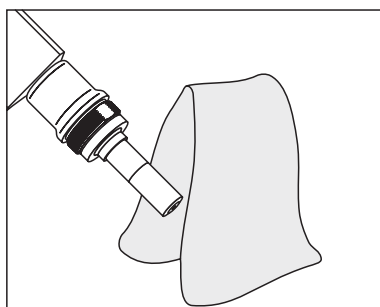

Wipe the counter electrode with a lint-free paper towel and carefully remove any loose white deposits.

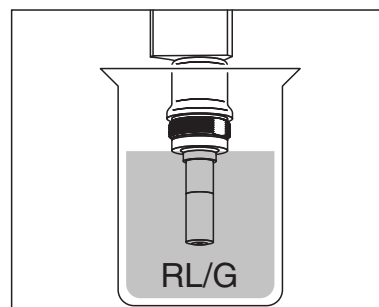

Immerse the sensor head including the counter electrode in RL/G cleaning solution.

Allow to react for 1 to 3 minutes.

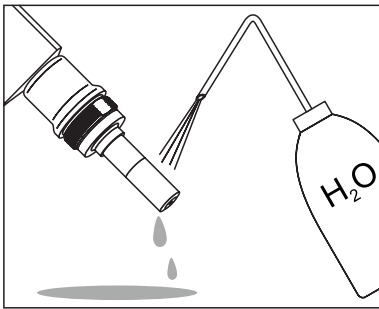

Thoroughly rinse the sensor head with deionized water.

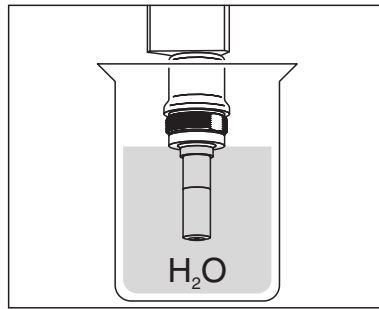

Water the counter electrode in deionized water for at least 10 minutes.

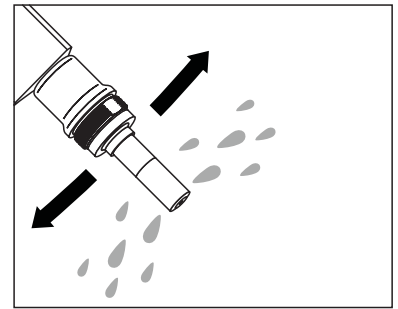

Carefully shake off the drops of water.

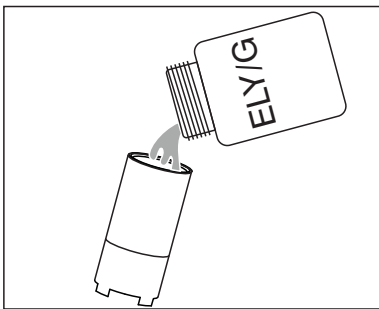

Fill a new membrane cap with ELY/G electrolyte solution.

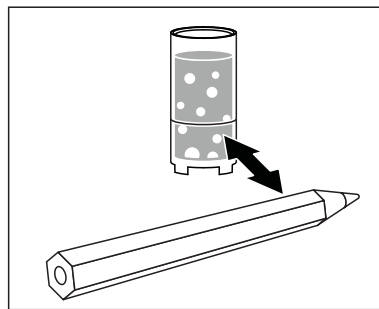

Remove any air bubbles by carefully tapping the membrane cap. Additionally, you can prevent air bubbles by throwing the first filling away and refilling the membrane cap.

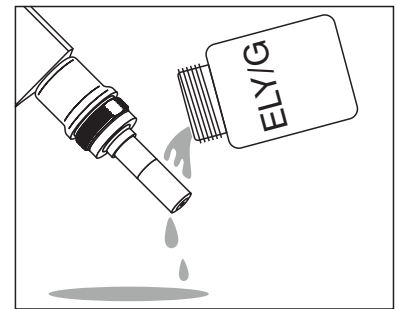

Rinse the sensor head with electrolyte solution.

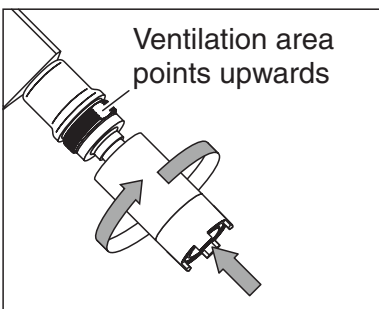

Hold the sensor inclined and screw on the membrane head fingertight using a paper towel. Excess electrolyte solution is forced out of the ventilation area.

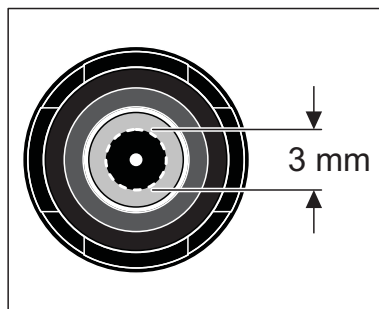

Check the filling: Inspect the face surface. No air bubbles may be present within the dashed circle. Air bubbles outside this area do not interfere.

Readiness to measure

To measure, plug in the stirring paddle.

After approx. 30 to 50 minutes, the sensor is ready for operation. Subsequently calibrate the sensor.



If you want to measure very low oxygen concentrations (< 0.5 % saturation), we recommend to let the sensor rest overnight and then calibrate it.

5.5 Checking the sensor for freedom from zero-current

The sensor is zero-current free. Checking the module for freedom from zero-current is only necessary in the case of malfunctions that cannot be remedied by exchanging the electrolyte solution and membrane cap or by cleaning the electrodes.

There are 2 possibilities to check the sensor for freedom from zero-current:

- Measurement in a nitrogen atmosphere (recommended method)
- Measurement in a sodium sulfite solution according to DIN EN 25814/ ISO 5814.



CAUTION

If you check the sensor according to DIN EN 25814/ISO 5814, do not leave the sensor in the sodium sulfite solution for more than 2 minutes. Danger of sensor poisoning!

Test criterion

The sensor is OK if the measuring instrument displays < 1 % D.O. saturation after 2 minutes.

5.6 Disposal



CAUTION

The ELY/G electrolyte solution irritates the eyes and skin. When dealing with the ELY/G electrolyte solution, observe the following points:

- **During working activities, always wear suitable protective gloves and protective goggles/face shield.**
- **If it comes into contact with the skin, rinse thoroughly with water and immediately change contaminated clothing.**
- **If it comes into contact with the eyes, rinse thoroughly with water and consult a doctor.**
- **Follow the safety datasheet.**

Sensor and membrane cap

For disposal, unscrew the membrane head and rinse the sensor and membrane head with water. We recommend disposing of the sensor without the membrane cap as electronic refuse. The membrane head may be

disposed of with the household refuse.

Electrolyte solution

Disposal according to the safety data sheet.

6 What to do if ...

Error symptom	Cause	Remedy
The sensor is in the air and the display shows 0.0 mg/l or 0 % O ₂	<ul style="list-style-type: none"> – No connection between measuring instrument and sensor – No electrolyte in the membrane head – Cable defective 	<ul style="list-style-type: none"> – Check connection between measuring instrument and sensor – Replace and refill the membrane cap (see section 5.3) – Return the sensor
The sensor cannot be calibrated	<ul style="list-style-type: none"> – Contaminated membrane head – Electrolyte depleted 	<ul style="list-style-type: none"> – Replace and refill the membrane cap (see section 5.3) – Subsequently, wait for 30 to 50 min and recalibrate.
The sensor still cannot be calibrated after changing the electrolyte and membrane cap	<ul style="list-style-type: none"> – Contaminated electrodes or sensor toxification 	<ul style="list-style-type: none"> – Clean the electrodes (see section 5.4)
Leak display appears	<ul style="list-style-type: none"> – Membrane cap not screwed on tight enough – Hole in the membrane 	<ul style="list-style-type: none"> – Screw membrane head tighter – Replace and refill the membrane cap (see section 5.3)
Incorrect temperature display	<ul style="list-style-type: none"> – Temperature sensor defective 	<ul style="list-style-type: none"> – Return the sensor
Mechanical damage to the sensor		<ul style="list-style-type: none"> – Return the sensor
Meter displays <i>OFL</i> (display range exceeded)	<ul style="list-style-type: none"> – Short-circuit between working electrode and counter electrode 	<ul style="list-style-type: none"> – Clean the electrodes (see section 5.4). If the meter still displays <i>OFL</i>, return the sensor.
Stirrer does not move	<ul style="list-style-type: none"> – No power supply – Stirring system defective 	<ul style="list-style-type: none"> – Connect power supply (small plug) – Return the sensor

7 Technical data

General features

Measuring principle	Membrane covered galvanic sensor
Temperature compensation	IMT compensation (calculated by the meter)
Temperature sensor	Integrated NTC 30 (30 kΩ at 25 °C / 77 °F)

**Dimensions
(in mm)**

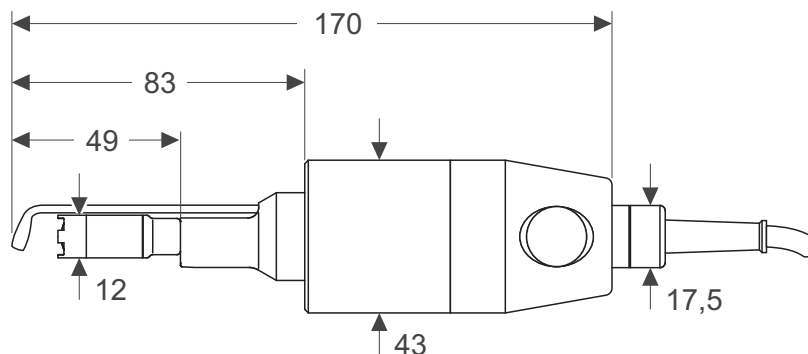

Weight 310 g (with 2 m cable)

Materials

Working electrode	Gold
Counter electrode	Lead
– Shaft housing	POM
– Connection head	
– Membrane head	
– Cable screw joint	
Membrane	FEP
Sensor head	Epoxy, PEEK
Insulator	PEEK
Thermistor housing	VA steel 1.4571
Seals	FPM (Viton)
Stirring paddle	VA steel 1.4571

Connection cable

Lengths	2 m
Diameter	6 mm
Smallest allowed bend radius	Fixed installation: 50 mm Flexible use: 120 mm
Plug type:	
– D.O. sensor	Socket, 8 pins
– Stirring system	Socket, 2 pins

Pressure resistance

Immersion part to maximum depth of immersion	IP 67
Sensor above maximum depth of immersion	IP 65



CAUTION

Do not expose the sensor to overpressure.

Measurement conditions	Measuring ranges at 20 °C (68 °F)	0 ... 50 mg/l D.O. 0 ... 600 % D.O. saturation 0 ... 1250 mbar D.O. partial pressure
	Temperature range	0 ... 50 °C (32 ... 122 °F)
	Depth of immersion (with stirring paddle)	min. 49 mm max. 83 mm
	Max. allowed overpressure	according to an immersion measurement up to the max. immersion depth
	Operating position	vertical with membrane cap downward
	Approach flow	by integrated stirring system
	Storage conditions	Recommended storing method
Storage temperature		0 ... 50 °C (32 ... 122 °F)
Characteristics when delivered	Zero signal	< 0.1 % of the saturation value
	Response time of D.O. measurement at 20 °C (68 °F)	t ₉₀ (90 % of the final value display after) < 10 s t ₉₅ (95 % of the final value display after) < 15 s t ₉₉ (99 % of the final value display after) < 45 s
	Reproducibility	< 0.3 %
	Own consumption of oxygen at 20 °C (68 °F)	0.008 µg·h ⁻¹ (mg/l) ⁻¹
	Drift	Approx. 3 % per month in the operating condition
	Response time of temperature measurement	t ₉₉ (99 % of the final value display after) < 60 s
	Precision of temperature measurement	± 0.2 K
	Working life	min. 6 months with one electrolyte filling

Maximum current consumption

U_e supply voltage
 I_0 quiescent current
 I_1 current in normal operation
 I_2 current with blocked stirrer

U_e / V	I_0 / mA	I_1 / mA	I_2 / mA
5.0	< 4.0	< 38	< 189
6.0	< 4.8	< 35	< 147
7.0	< 5.8	< 32	< 137
8.0	< 6.7	< 29	< 121
9.0	< 7.7	< 28	< 108
10.0	< 8.6	< 27	< 100
11.0	< 9.5	< 27	< 95
12.0	< 10.4	< 27	< 89

Maximum power consumption

1 W

Pin assignment

Plug (8 Pin) from the front:

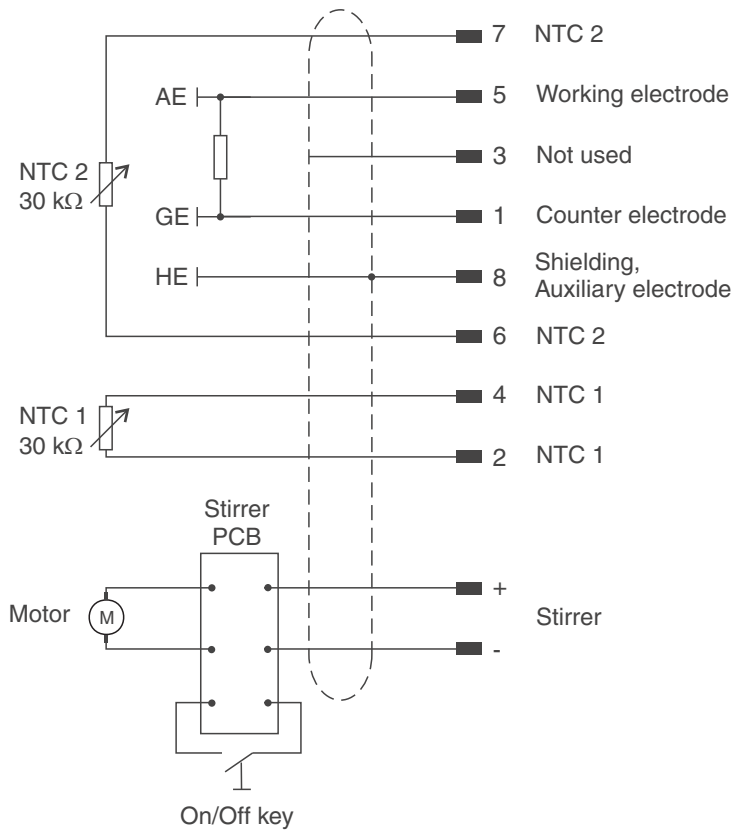
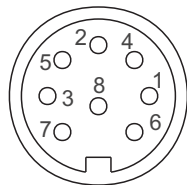

Plug (2 Pin) from the front:



8 Wear parts and accessories

Wear parts and maintenance equipment

Description	Model	Order no.
Set of exchange membrane caps (3 pieces)	WP3-ST	202 738
Electrolyte solution	ELY/G	205 217
Cleaning solution for lead counter electrode	RL/G	205 204
Polishing film	SF 300	203 680
Accessory kit, comprising: – 3 exchange membrane caps, WP-ST – Electrolyte solution ELY/G – Cleaning solution, RL/G – Polishing strip, SF 300	ZBK-ST	202 710
Stirring paddle	RP-ST	204 122

Accessories

Description	Model	Order no.
Calibration and storage vessel	OxiCal [®] -ST	205 349
Stand for OxiCal [®] -ST	Sta-ST	205 348
Karlsruhe bottle - suitable for BOD measurement	KF 12	205 700



For further accessories, refer to the WTW catalog or the Internet

What can Xylem do for you?

We're a global team unified in a common purpose: creating innovative solutions to meet our world's water needs. Developing new technologies that will improve the way water is used, conserved, and re-used in the future is central to our work. We move, treat, analyze, and return water to the environment, and we help people use water efficiently, in their homes, buildings, factories and farms. In more than 150 countries, we have strong, long-standing relationships with customers who know us for our powerful combination of leading product brands and applications expertise, backed by a legacy of innovation.

For more information on how Xylem can help you, go to xyleminc.com.



Service address:

Xylem Analytics Germany
Sales GmbH & Co. KG
WTW
Dr.-Karl-Slevogt-Str. 1
82362 Weilheim
Germany

Tel.: +49 881 183-325
Fax: +49 881 183-414
E-Mail wtw.rma@xyleminc.com
Internet: www.WTW.com



Xylem Analytics Germany GmbH
Dr.-Karl-Slevogt-Str. 1
82362 Weilheim
Germany