

PB-W

SAMPLER FOR WALL MOUNTING



a xylem brand



Access code for
program changes or changes of system settings

Password: **6299**

Your password:

Table of Contents

1	Technical Data	4
2	Safety information	6
2.1	Use of hazard information.....	6
2.2	Precautionary labels	7
3	General Information	8
3.1	Areas of application	8
3.2	Functional description.....	8
3.3	Product contents	8
4	Installation	9
4.1	Mechanical Installation	10
4.1.1.	Required tools.....	10
4.1.2.	Installation location.....	11
4.2.	Electrical Connections	12
5.	Commision of the equipment	14
5.1.	Tube connection	14
5.2.	Set the individual sample volumes	15
5.2.1.	Plastic dosing vessel.....	15
5.2.2.	Glas-Dosing vessel	16
5.3.	Connect the equipment to the mains	18
6.	Controlling	20
6.1.	Control unit operation	20
6.1.1.	Programming	20
6.1.2.	Keyboard layout/function.....	20
7.	Maintenance and cleaning	23
7.1.	Maintenance work	23
7.2.	Cleaning	23
7.2.1.	Cleaning the housing	23
7.2.2.	Clean the dosing vessel.....	24
7.3.	Troubleshooting	25
7.3.1.	Change the fuse.....	25
7.4.	Instrument decommissioning and storage	26
8.	Warranty and liability	27

1 Technical Data

These are subject to change without notice.

Sampling method	Vacuum-System
Sample fractioning	Composite container (PE): 1 x 27.3 pt. (13 l), 1 x 52.5 pt. (25 l)*
Dosing	0.042 ... 0.735 pt. (20 ... 350 ml)
Sampling modes	Time-, amount-, event-dependent or manual
Manual sampling extraction	Possible at any time without interrupting the current program run
Volume accuracy	< 2,5 % or ± 0.0063 pt. (3 ml)
Sampling temperature	+32 ... +104 °F (0 ... 40 °C)
Ambient temperature	+32 ... 113 °F (0 ... +45 °C)
Suction height	Max. 21 ft. (6.5 m) at 1013 hPa
Suction tube	PVC, 16 ft. (5 m), 0.39 in (10 mm), fabric-reinforced**
Signal inputs	2 x 0(4) ... 20 mA 8 x digital (Amount, event, freely programmable)
Signal outputs	8 x digital, 1x of them freely programmable
Programming	12 programs (freely programmable); with function to link programs
Program start	Immediately, at a certain time, by an external signal
Program stop	End of sampling program after one program run, continuous operation or x-runs
Pause mode	Interruption of program run at any time
Languages	Multi-language, selectable
Status messages	1 x collective malfunction message, expandable with 8 (freely programmable)
Data logger	3000 entries, nonvolatile data memory, storage of sampling and malfunction data (sampling extraction, bottle changes, messages, messages, external signals)
Interfaces	Mini-USB, RS422/485, Ethernet RJ45 (optional)

*) further configurations on request

**) expandable per meter, max. length 98 ft (30 m)

Housing	PS/PC (GF10)
Protection	IP65 (for control unit)
Wetted materials	PC, PVC, Silicone, PS, PE
Dimensions	14.25 x 17.4 x 8.74 in (362 x 442 x 222mm) (HxWxD)

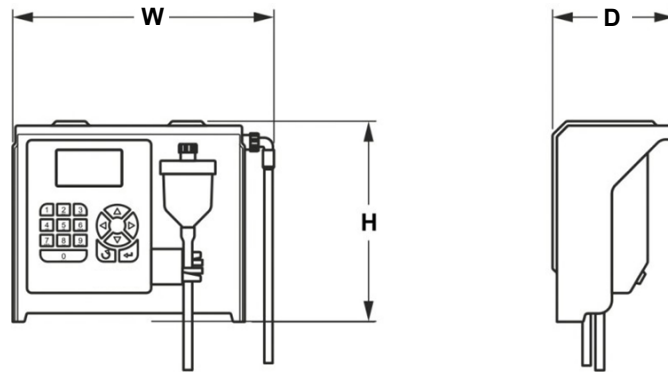

W: 17.4 in (442 mm)
H: 14.25 in (362 mm)
D: 8.74 in (222 mm)

Fig. 1: Dimensions

Weight	22 lb (10 kg)
Power supply	230V / 115V
Standards	CE, sampling according to ISO 5667-2/3-10

2 Safety information

Please read this entire manual before unpacking, setting up or operating this equipment. Pay attention to all danger and caution statements. Failure to do so may result in personal injury or damage to the instrument.

To ensure that the protection provided by this equipment is not impaired, do not use or install this equipment in any manner other than that specified in this manual.

2.1 Use of hazard information



DANGER

Indicates a potentially or imminently hazardous situation which, if not avoided, will result in death or serious injury.



WARNING

Indicates a potentially or imminently hazardous situation that, if not avoided, could result in death or serious injury.



CAUTION





Indicates a potentially or imminently hazardous situation that could result in minor or moderate injury.

Important note: Information that requires special emphasis.

Note: Information that supplements points in the main text.

2.2 Precautionary labels

Read all labels and tags attached to the instrument. Failure to do so may result in personal injury or damage to the instrument. A symbol, if noted on the instrument, will be included with a danger or caution statement in the manual.

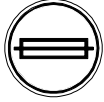
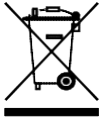
	<p>This symbol, if noted on the instrument, references the user manual for operation and/or safety information.</p>
	<p>This symbol, when noted on a product enclosure or barrier, indicates that a risk of electrical shock and/or electrocution exists.</p>
	<p>This symbol may appear on the product and indicates the need for protective eye wear.</p>
	<p>This symbol may appear on the product and identifies the connection point for the protective ground.</p>
	<p>When this symbol appears on the product, it identifies the location of a fuse or a current limiter.</p>
	<p>Electrical equipment marked with this symbol may not be disposed of in European domestic or public disposal systems after 12 August 2005. In conformity with European local and national regulations (EU Directive 2002/96/EC), European electrical equipment users must now return old or end-of-life equipment to the manufacturer for disposal at no charge to the user Note: For return for recycling, please contact the equipment manufacturer or supplier for instructions on how to return end-of-life equipment, manufacturer-supplied electrical accessories, and all auxiliary items for proper disposal.</p>

3 General Information

3.1 Areas of application

The equipment is used for sampling aqueous liquids with a temperature of +32 ... +104 °F (0 ... 40 °C).

3.2 Functional description

The equipment provides temporary storage for liquids of a specified volume so that they can be analyzed.

3.3 Product contents

The equipment is supplied with a tube and brief operating instructions.

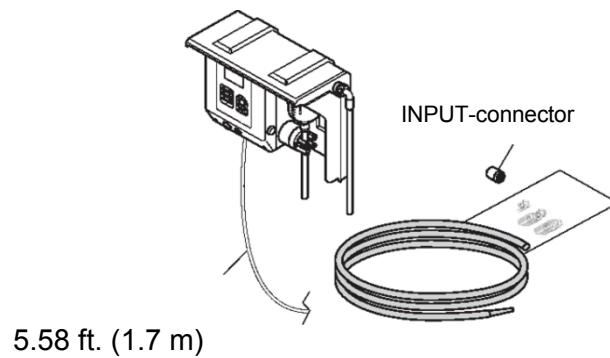

Fig. 2: Product contents

4 Installation



DANGER

Only qualified experts should conduct the tasks described in this section.



DANGER

Select an appropriate installation location for the instrument.

Plan out the mechanical mount before positioning poles or drilling holes. Make sure the mount has a sufficient bearing capacity. The dowels must be selected and authorized according to the condition of the wall.

The manufacturer shall accept no liability if the instrument is installed incorrectly.

Plan how to lay cables and tubes and their path in advance. Lay the tubes, data cables and power cables without any bends and so they do not pose a tripping risk.

Do not connect the electrical supply to the mains if the equipment has not been wired and fused correctly.

Sufficiently protect the electrical power supply against short circuits.

For the external power supply, always connect a residual-current circuit breaker (trip current max.: 30 mA) between the mains and the system.

If the equipment is to be installed outdoors, switch the overload protection between mains and system.

Products intended by the manufacturer for outdoor use offer a higher level of protection against the penetration of liquids and dust. If these products are connected to a mains outlet with a cable and plug rather than a permanently connected cable, the plug and outlet are much more susceptible to liquid and dust penetration. The operator must sufficiently protect the plug and outlet against liquid and dust penetration in accordance with local safety regulations. If the instrument is to be used outdoors, it must be connected to a suitable outlet with a protection type of at least IP44 (splash protection).

4.1 Mechanical Installation

DANGER



Select an appropriate installation location for the instrument. Plan out the mechanical mount before positioning poles or drilling holes. Make sure the mount has a sufficient bearing capacity. The dowels must be selected and authorized according to the condition of the wall.

The manufacturer shall accept no liability if the instrument is installed incorrectly.

Plan how to lay cables and tubes and their path in advance. Lay the tubes, data cables and power cables without any bends and so they do not pose a tripping risk.

Note: For information on installation with optional accessories, refer to the relevant installation instructions.

4.1.1. Required tools

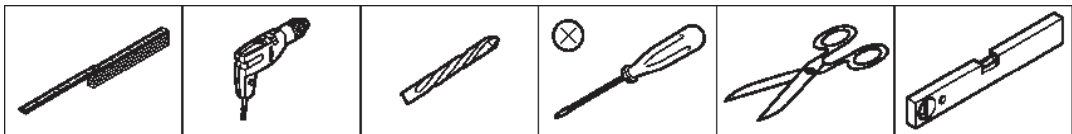

Fig. 3: Required tools

4.1.2. Installation location

Select suitable fastening materials (e.g. 0.24 x 1.57 in (6 x 40 mm) screws and corresponding dowels) and read all the safety information about installation and mechanical assembly. The measurement location must meet the environmental conditions specified in section 1 TECHNICAL DATA. The sampler is designed for operation in an environment protected against moisture.

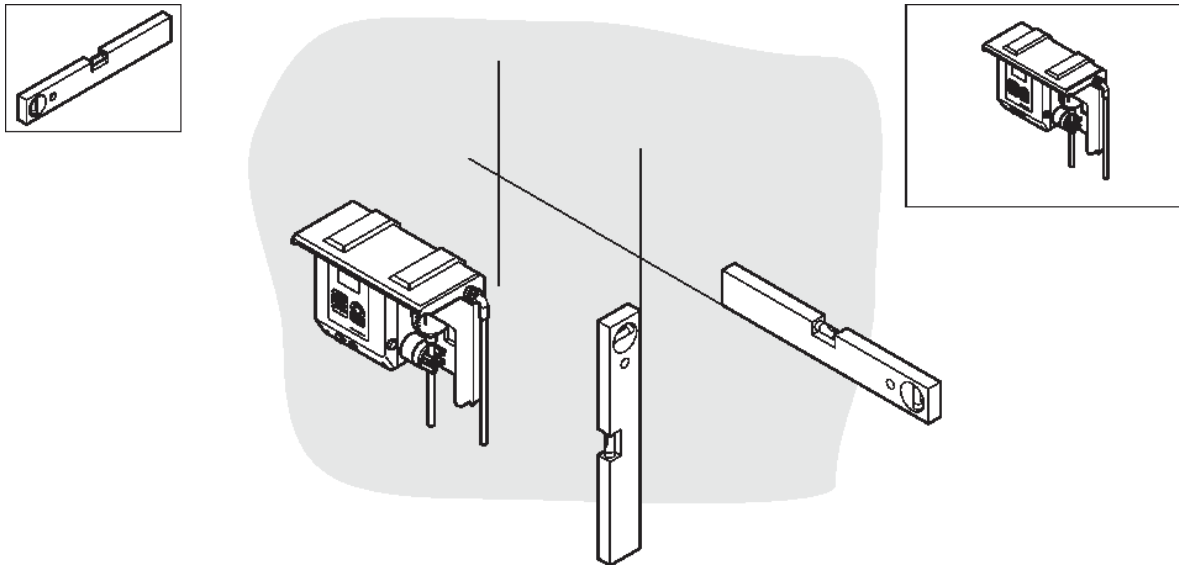

Fig. 4: Select installation location

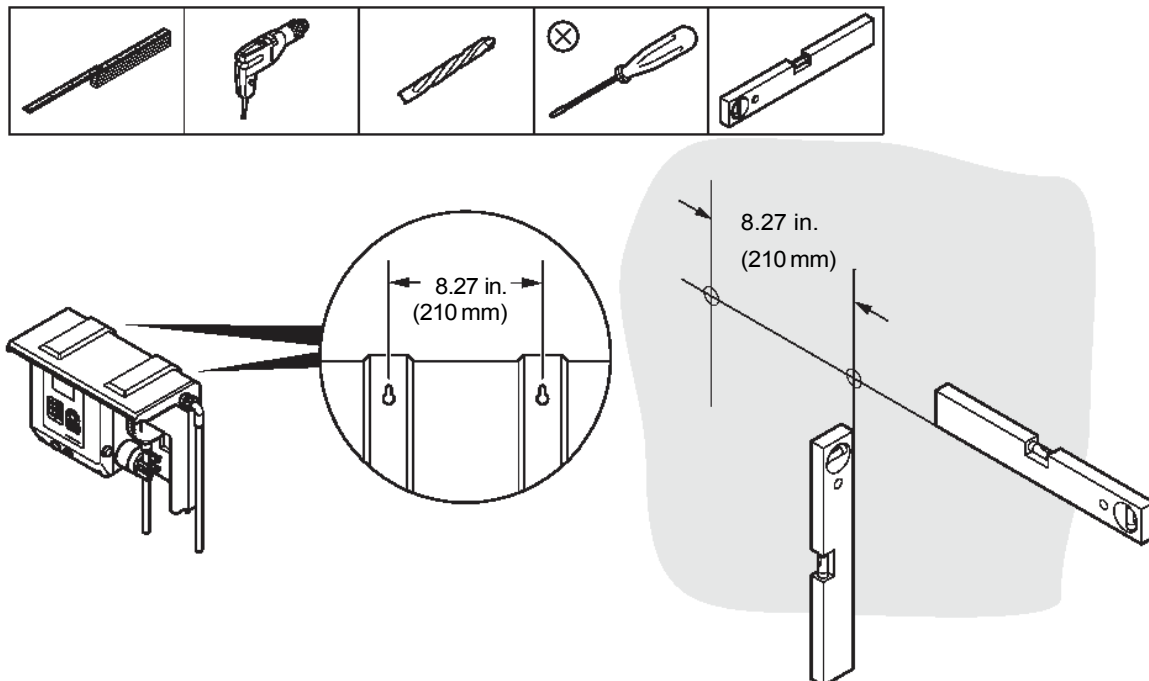

Fig. 5: Attach the equipment

4.2. Electrical Connections

DANGER



Only qualified experts should conduct the tasks described in this section.

DANGER



Do not connect the electrical supply to the mains if the equipment has not been wired and fused correctly.

Sufficiently protect the electrical power supply against short circuits.

For the external power supply, always connect a residual-current circuit breaker (trip current max.: 30 mA) between the mains and the system.

If the equipment is to be installed outdoors, switch the overload protection between mains and system.

If the mains plug of the power supply cable is removed, a suitable double-pole one-way switch must be installed immediately next to the display unit with clear labeling for the power supply.

Products intended by the manufacturer for outdoor use offer a higher level of protection against the penetration of liquids and dust. If these products are connected to a mains socket with a cable and plug rather than a permanently connected cable, the plug and socket are much more susceptible to liquid and dust penetration. The operator must sufficiently protect the plug and outlet against liquid and dust penetration in accordance with local safety regulations. If the instrument is to be used outdoors, it must be connected to a suitable outlet with a protection type of at least IP44 (splash protection)

Please note:

- the assignment of the connections in the illustration below
- the cable color of the label on the cable.

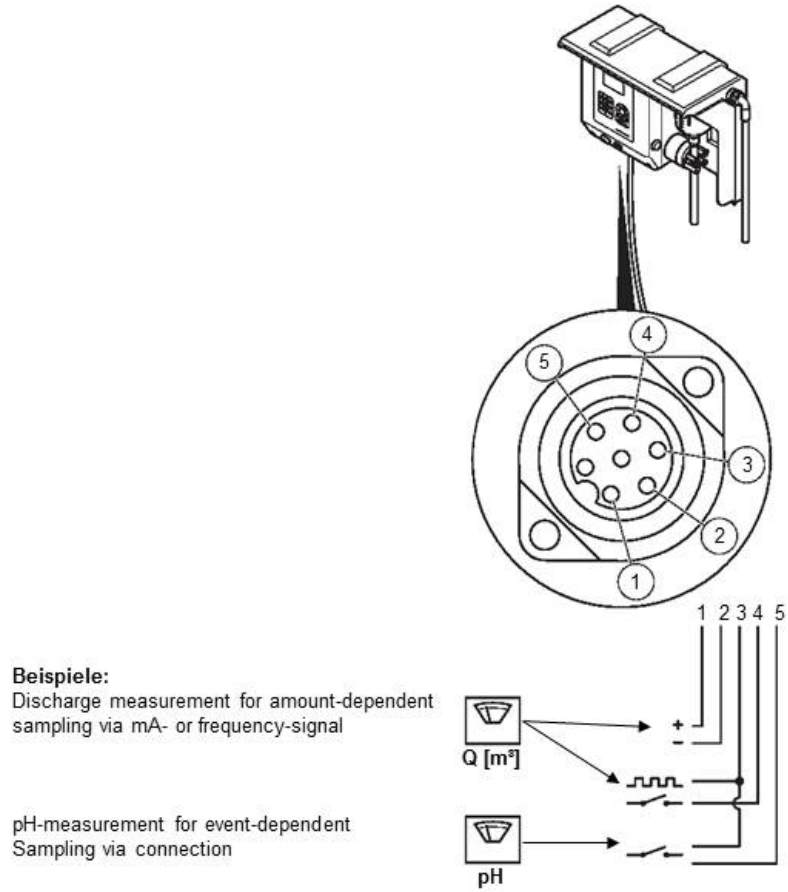

Fig. 6: Connection plan for the optional signal cable

5. Commision of the equipment

5.1. Tube connection

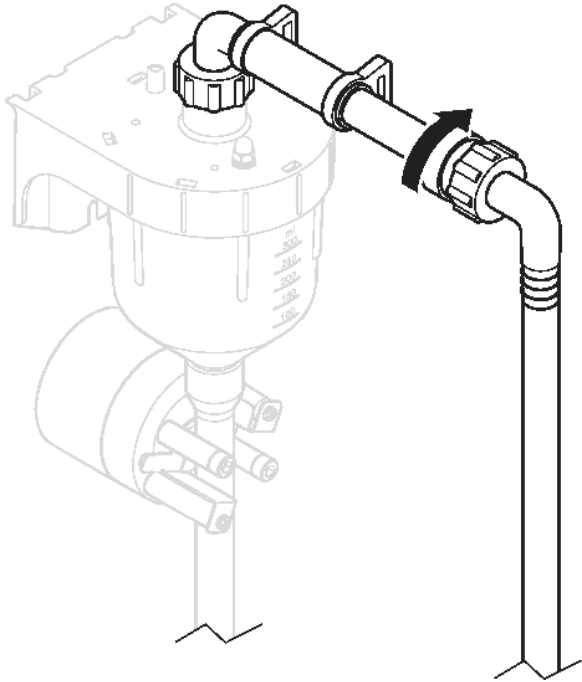

Fig. 7: Connect the sample tube connection

Positioning of the tubes according to the following installation diagram

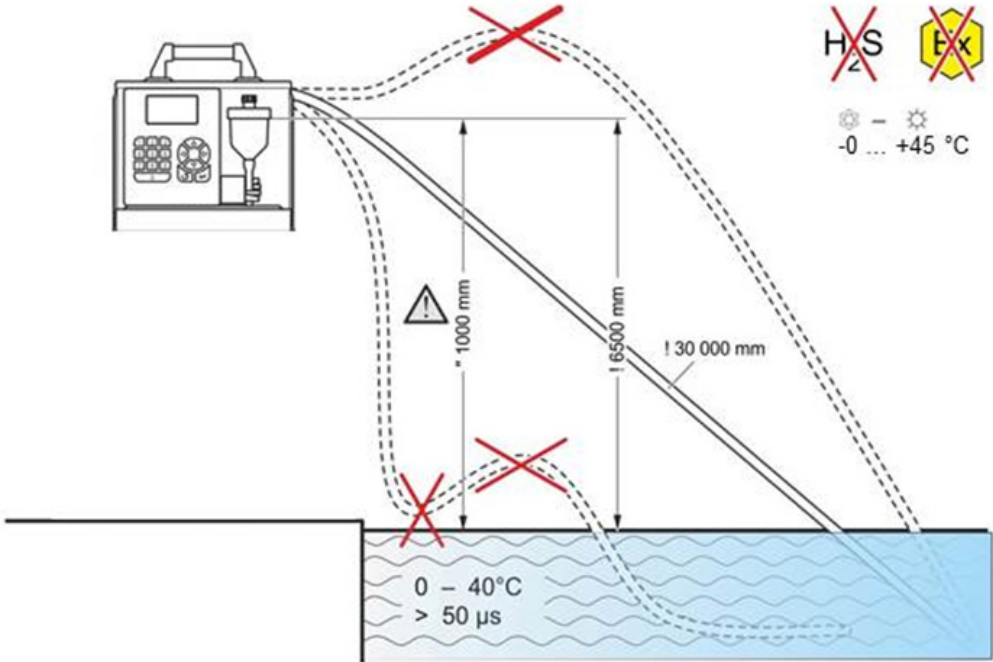

Fig. 8: Installation diagram

5.2. Set the individual sample volumes

5.2.1. Plastic dosing vessel

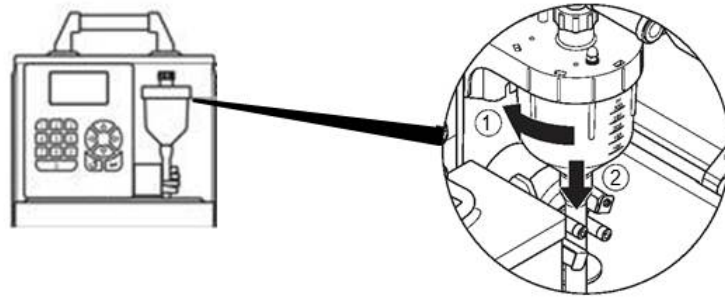

Fig. 9: Unlock the bayonet cap on the plastic dosing vessel

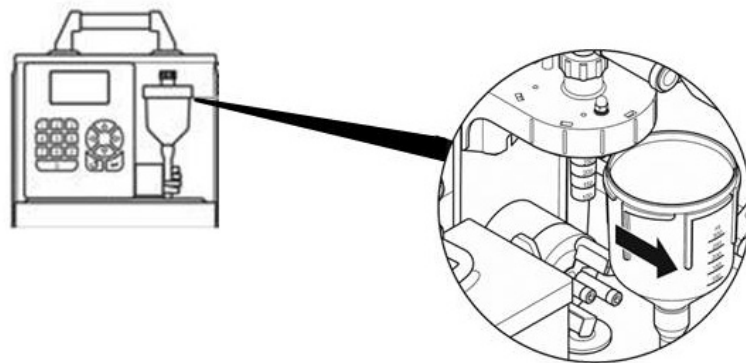

Fig. 10: Remove the plastic dosing vessel

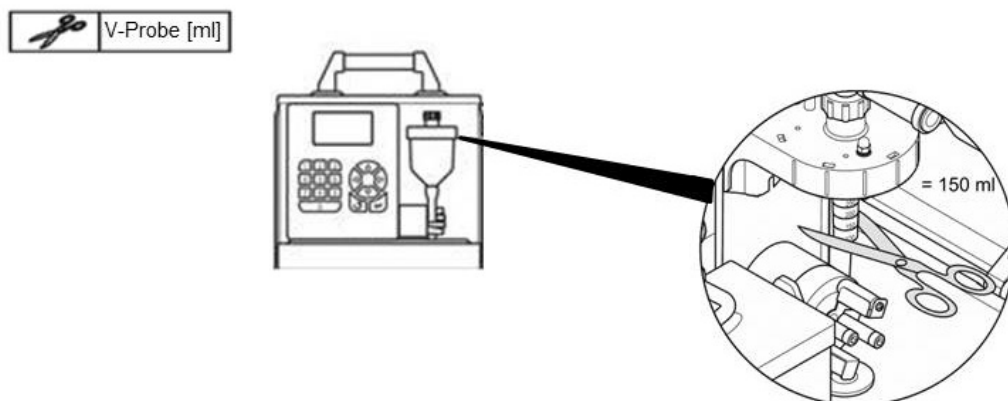

Fig. 11: Cut the dosing tube to set the sample volume (150 ml = 0.315 pt.)

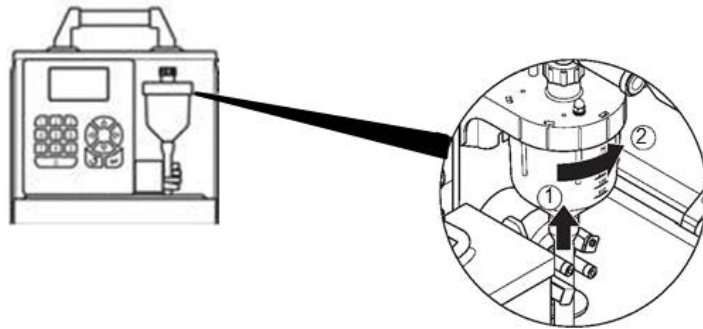

Fig. 12: Assemble the plastic dosing vessel

5.2.2. Glas-Dosing vessel

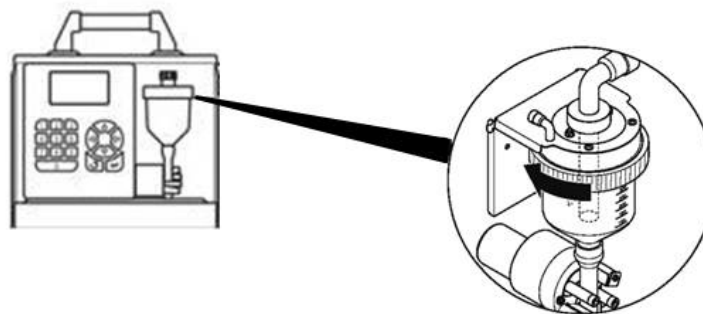

Fig. 13: Loosen the union nut on the glass dosing vessel

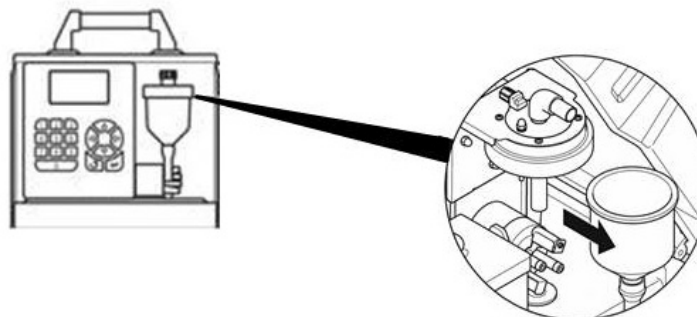

Fig. 14: Remove the glass dosing vessel

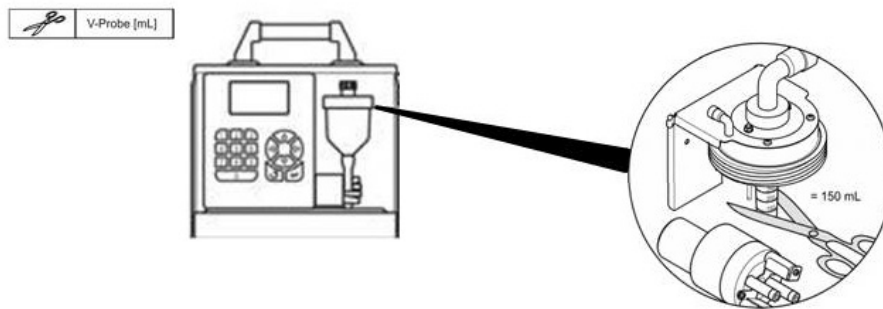

Fig. 15: Cut the dosing tube to set the sample volume (150 ml = 0.315 pt.)

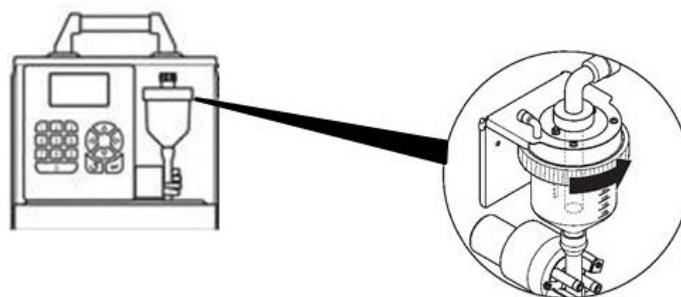

Fig. 16: Assemble the glass dosing vessel

5.3. Connect the equipment to the mains

Make sure that:

- the equipment has been fully prepared for commissioning
- the data on the type plate corresponds to the data relating to the mains power supply
- the correct plug has been attached or the direct wire has been implemented correctly
- the equipment can be put into operation without any risks



DANGER

Make sure that the power supply, cable and equipment are suitable for use with each other.



Fig. 17: Rating label

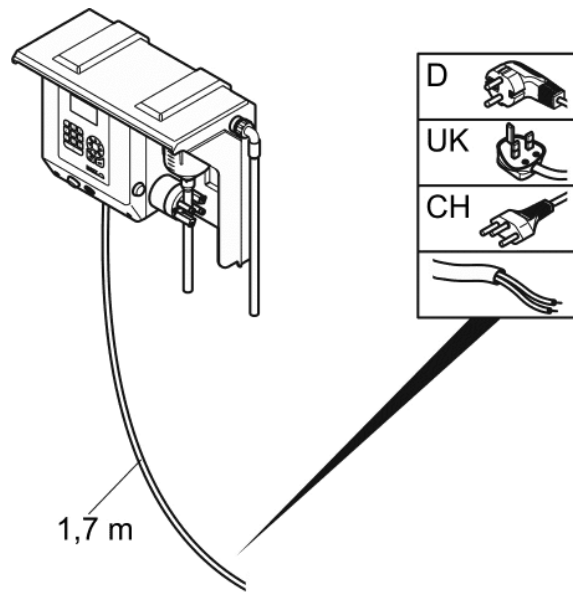

Fig. 18: Possible connection configurations (1.7m = 5.58 ft.)

Switch on the device

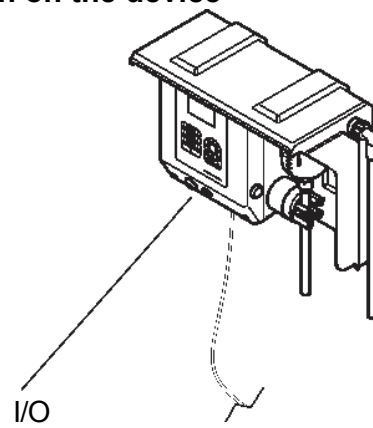

Fig. 19: Switch on the device

6. Controlling

6.1. Control unit operation

All the equipment functions are software-controlled.

6.1.1. Programming

The menu structure resembles the directory structure of a computer hard drive and is divided into main menus and sub menus.

6.1.2. Keyboard layout/function

The equipment can be programmed by the operator.

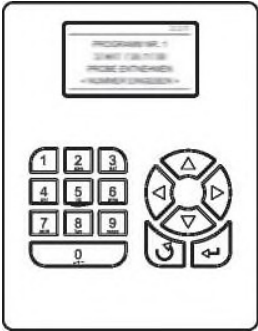

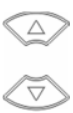













Fig. 20: Control panel

The key functions are configured as follows to enable highly intuitive operation:

Tab. 1: Key functions

Display help text (in the case of selection fields, the cursor must be placed on the left-hand side)	Arrow key	
Move from one menu item to the next menu selection	Arrow key	
Select the desired menu	Enter-key	
Move within a menu	Arrow key	
Select from within a menu	Arrow key	
Confirm the selection (automatically marked with a ✓)	Enter-key	
Enter/change values	Arrow key	
Confirm the entered values	Enter-key	
Return to the next superordinate menu level	Back-key	
Enter values	Numeric keypad	
Initialise (Reset) of Display – Press together	Back-key + Enter-key	 + 
Wakeup sleepmode (press 5 sec. At least)	Back-key	
Restore factory settings (Display = „load factorysettings“). Hold Back-key until boot process is finished.	Back-key	

Example: A setting needs to be changed.

1. Use the arrow keys to move the cursor until it is in the required position
2. Press enter. The selection is now confirmed and the program can be started

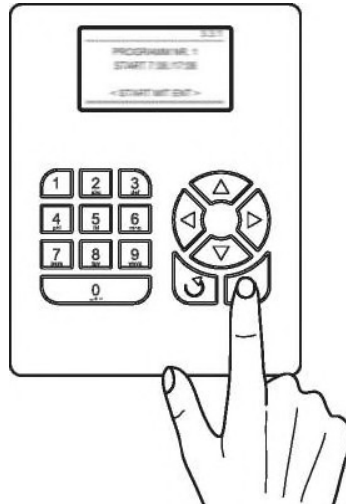

Fig. 21: Start the program

Depending on the program range,

- An activity is started or
- The next menu item is automatically selected.

Note: *The general rule:*

If you press Back,

- *The activity is cancelled or*
- *The navigation takes one step back in the menu.*

7. Maintenance and cleaning

DANGER



Only qualified experts should conduct the tasks described in this section.

WARNING



Please observe the following points for the use of chemicals and/or waste water:

Wear protective clothing:

- laboratory coat***
- protective eyewear***
- rubber gloves***

7.1. Maintenance work

The sampler is maintenance-free. Thus the operator does not need to carry out any maintenance works.

7.2. Cleaning

7.2.1. Cleaning the housing

Clean the interior and exterior of the housing with a damp, lint-free cloth. Add commercial household cleaner to the cleaning water as required.

7.2.2. Clean the dosing vessel

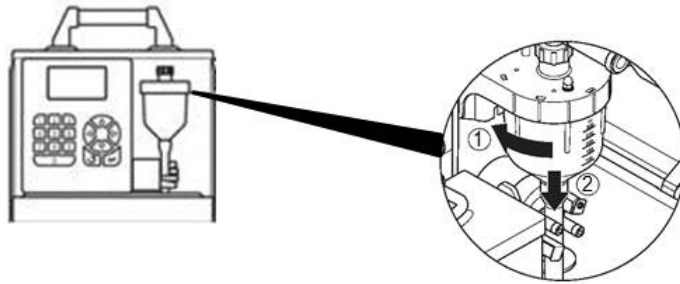

Fig. 22: Release the dosing vessel

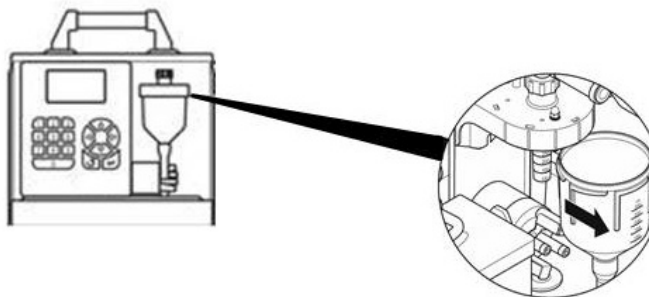

Fig. 23: Remove the dosing vessel

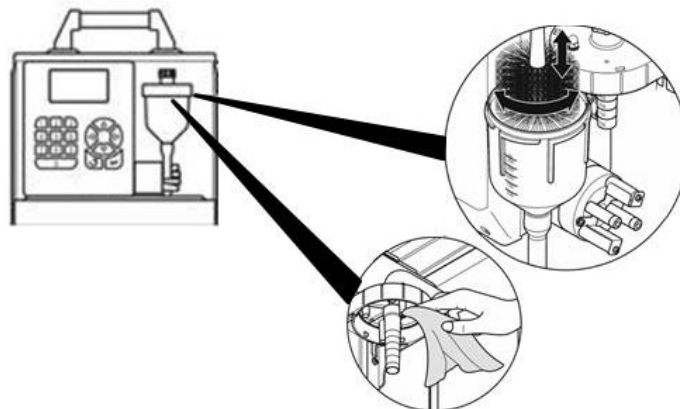

Fig. 24: Clean the dosing vessel

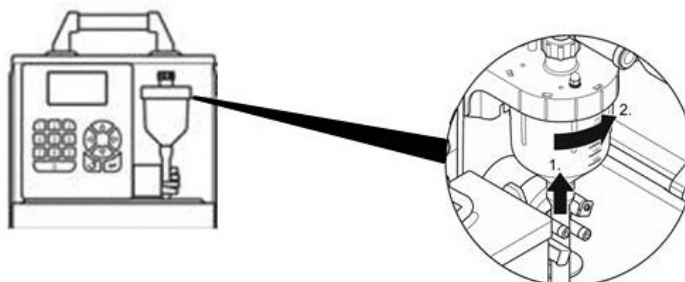

Fig. 25: Insert the dosing vessel

7.3. Troubleshooting

If the equipment does not work as required, check the fuse and replace if necessary.

7.3.1. Change the fuse

Open the fuse holder and replace the defective fuse.

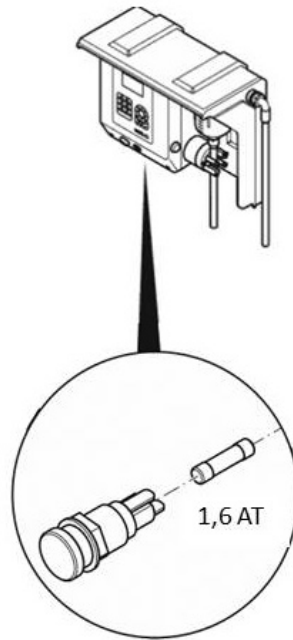

Fig. 26. Position of the fuse in the sampler

If the error is not rectified, please contact the customer service of the manufacturer

7.4. Instrument decommissioning and storage

1. Remove all liquids and, if necessary, solid matter from the infeed and outfeed lines and bottle compartments and clean as required.
2. Close all active programs.
3. Switch off the equipment.

8. Warranty and liability

The manufacturer warrants that the product supplied is free of material and manufacturing defects and undertakes the obligation to repair or replace any defective parts at zero cost.

The warranty period is 12 months from delivery resp. invoice date. Consumables and damage caused by improper handling, poor installation or incorrect use are excluded from this clause

With the exclusion of the further claims, the supplier is liable for defects including the lack of assured properties as follows: all those parts that, within the warranty period calculated from the day of the transfer of risk, can be demonstrated to have become unusable or that can only be used with significant limitations due to a situation present prior to the transfer of risk, in particular due to incorrect design, poor materials or inadequate finish will be improved or replaced, at the supplier's discretion. The identification of such defects must be notified to the supplier in writing without delay, however at the latest 7 days after the identification of the fault. If the customer fails to notify the supplier, the product is considered approved despite the defect. Further liability for any direct or indirect damages is not accepted.

If instrument-specific maintenance and servicing work defined by the supplier is to be performed within the warranty period by the customer (maintenance) or by the supplier (servicing) and these requirements are not met, claims for damages due to the failure to comply with the requirements are rendered void.

Any further claims, in particular claims for consequential damages cannot be made.

Consumables and damage caused by improper handling, poor installation or incorrect use are excluded from this clause.

What can Xylem do for you?

We're a global team unified in a common purpose: creating innovative solutions to meet our world's water needs. Developing new technologies that will improve the way water is used, conserved, and re-used in the future is central to our work. We move, treat, analyze, and return water to the environment, and we help people use water efficiently, in their homes, buildings, factories and farms. In more than 150 countries, we have strong, long-standing relationships with customers who know us for our powerful combination of leading product brands and applications expertise, backed by a legacy of innovation.



Xylem Analytics Australia
www.xylem-analytics.com.au

Xylem Analytics Asia Pacific
www.xylem-analytics.asia

Xylem Analytics South Asia
www.xylem-analytics.in

For more details, contact us at
info.apac@xylem.com