



Smith-Blair
a xylem brand

Installation Instructions

923 Flange Lock Flanged Coupling Adapter Sleeve

STEP 1

Inspect the shipment to ensure no damage has occurred during transit or storage. Verify that the product received is the correct type and size for the application.

STEP 2

Install restrained flanged coupling adapter per restraint manufacturer's instructions and/or applicable portions of the latest edition of AWWA C111.

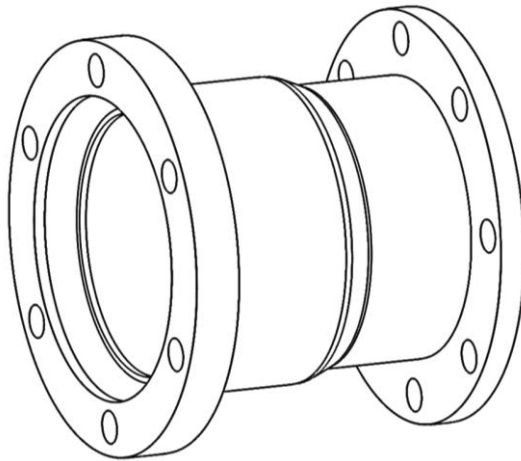

*923 Flange Lock
Flanged Coupling Adapter Sleeve*



THIS PRODUCT DOES NOT RESTRAIN PIPE MOVEMENT.

Proper anchoring is required to prevent pipe pull out. Failure to anchor or improper anchoring can result in dangerous pipe content escape, property damage, serious injury, and/or death. Read the product installation instructions prior to installing this product.

WARRANTY

Smith-Blair, Inc. warrants its products to be free of defects in materials and workmanship for a period of one (1) year from the date of shipment by Smith-Blair, Inc. (the "Warranty Period"). Dated proof of purchase, such as a bill of sale, is required to establish warranty eligibility. If a product fails to perform due to a defect in materials or workmanship during the Warranty Period, Smith-Blair, Inc. will repair or, at Smith Blair, Inc.'s option, replace the product with the same or comparable item. In the event that the product cannot be repaired and a suitable replacement item is not available, Smith-Blair, Inc. will refund the original purchase price shown on the proof of purchase. In all cases, the customer is responsible for returning the allegedly defective product to the factory or warehouse designated by Smith-Blair, Inc.

THIS LIMITED WARRANTY IS EXCLUSIVE AND IS IN LIEU OF ANY EXPRESS OR IMPLIED WARRANTY OF MERCHANTABILITY, FITNESS FOR A PARTICULAR PURPOSE, OR OTHER WARRANTY OF QUALITY, OR THOSE ARISING FROM A COURSE OF DEALING, CUSTOM, OR USAGE OF TRADE. THE REMEDIES PROVIDED IN THIS LIMITED WARRANTY STATEMENT ARE THE CUSTOMER'S SOLE AND EXCLUSIVE REMEDIES. IN NO EVENT SHALL SMITH-BLAIR, INC. BE LIABLE FOR DIRECT, INDIRECT, SPECIAL, INCIDENTAL, OR CONSEQUENTIAL DAMAGES, WHETHER BASED ON CONTRACT, TORT, OR ANY OTHER LEGAL THEORY, AND WHETHER ADVISED OF THE POSSIBILITY OF SUCH DAMAGES.

04/18

CORROSION & PRODUCT SELECTION NOTICE

Metal products are subject to corrosion, particularly when used outdoors and/or underground. A large number of factors and local conditions affect the rate of corrosion. Consult a local corrosion expert to determine the life expectancy of this product when used with your pipeline content, soil, and environment. Also, consult your system designer to determine the suitability of this product in your piping system. Failure to determine the suitability of this product in your application, soil, and/or environment can result in premature product failure. Smith-Blair will provide additional information about this product's material specifications at your request. You may also obtain product information at www.smith-blair.com.

04/18