



# MagFlux®

## ELECTROMAGNETIC FLOW METER

3.05

### General

MagFlux® Electromagnetic Flow Meters deliver very stable and highly accurate flow measurements in conductive liquids.

MagFlux® Flow Meters have no moving parts to create hydraulic influence on the flow, use a well-proven technology developed by MJK and communicate using a standard protocol.

MagFlux® Flow Sensors are available in sizes ranging from DN 15 to DN 2000\*, with standard construction lengths and connections. The MagFlux® Flow Meter, which makes the calculations of the flow, can be installed either with the converter mounted on the MagFlux® Flow Sensor, on a wall or mounted in a panel.

**MagFlux® Q** is a special edition of MagFlux® produced in composite materials and particularly suitable for salt water and low flowrate measurements. Its construction without external metal parts makes MagFlux® Q the perfect solution for installations where there is corrosion. MagFlux® Q is available from DN50 to DN150.

### Features

- One graphic display can operate up to four MagFlux® Flow Meters.
- Intuitive menu structure with easy navigation.
- Built-in datalogger with the display.
- Large dynamic measuring range with an accuracy of up to  $\pm 0,25\%$ .
- Two dynamic batch counters and password protection.
- Counters and pulse output with or without reset.
- 4-20 mA output for flow in one or both directions.
- Detection of empty pipe and automatic electrode cleaning.
- Full bore bi-directional sensor.
- Modbus® communication is utilized between the display and flow converter and to other external devices.

### Features - MagFlux® Q

- Low weight.
- Sensor in ABS plastic and Hastelloy C electrodes.
- Ideal for applications with saline water, e.g. aquaculture.
- Fully integrable with classic MagFlux® sensors and converters.

### Applications

MagFlux® is used to measure and log conductive fluids (drinking water, wastewater and process fluids) in both directions in closed and possibly pressurized pipe systems.

In addition, **MagFlux® Q** is used for installations with saline and/or seawater (even heated). And the high precision at very low speed makes MagFlux® Q perfect for district wells where night flow measurement can eliminate water loss even at very small leaks.

*\*) Does not apply to MagFlux® Q.*



### DATASHEET

EN 3.05 MAGFLUX DATASHEET 2004

# MagFlux® Electromagnetic Flow Meter

## Function

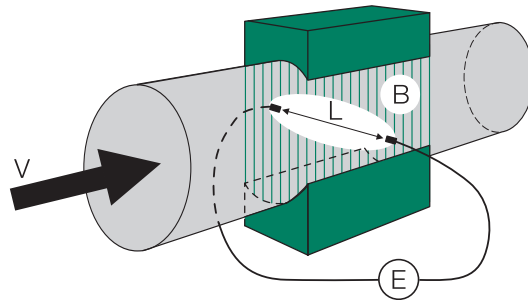

The MagFlux® operation is based on Faraday's law of induction. When a conductive fluid passes through a magnetic field in the sensor, an electromagnetic voltage is induced between the two electrodes in the flow sensor tube. This voltage (E) is directly proportional to the fluid velocity.

When the internal diameter of the flow sensor is known, the actual volume is calculated by the converter.

The electromagnetic voltage induced between the electrodes equates to:

$$E = L \times B \times V \text{ where:}$$

E: Induced electromagnetic voltage

L: Flow sensor diameter

B: The strength of the magnetic field

V: The velocity of the liquid

The voltage E is measured and consequently converted to a volumetric flow.

## Flexible Installation

MJK's modular design is versatile. The MagFlux® Display Unit can be mounted up to 1000 m from the MagFlux® Flow Converter with ordinary twisted wires. It also provides options for mounting the Converter where it is most convenient to make the electrical connections.

For greater economy, space savings and an improved overview of the multiple measurement values, one MagFlux® Display Unit can control up to four MagFlux® Converters and MagFlux® Flow Sensors



The MagFlux® Converter and Display Unit mounted directly on the MagFlux® Flow Sensor.



The MagFlux® Converter mounted directly on the MagFlux® Flow Sensor with a remotely mounted MagFlux® Display Unit.



The MagFlux® Converter and MagFlux® Display Unit remotely mounted. For example, when the sensor is buried or submerged.







The MagFlux® Converter mounted remotely from the MagFlux® Flow Sensor, and the MagFlux® Display Unit mounted separately from the Converter. E.g. when the MagFlux® Sensor is buried

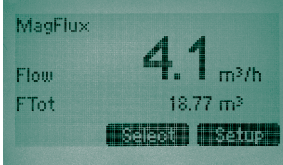

The MagFlux® Converters mounted directly on the MagFlux® Flow Sensors, while the remotely mounted MagFlux® Display Unit communicates with two MagFlux® Converters and MagFlux® Flow Sensors.

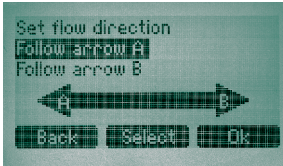
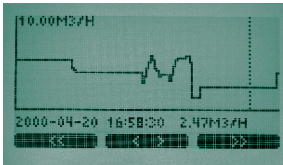
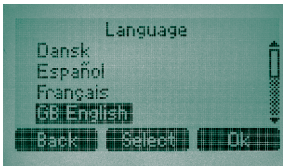
# MagFlux® Electromagnetic Flow Meter

Simple to Operate	The MagFlux® Display Unit has many unique and intelligent functions. It has a simple menu structure and can display text in several selectable languages in metrics or English units.	
Registering the MagFlux® Flow Sensor	The MagFlux® system registers the MagFlux® Flow Sensor to the MagFlux® Converter using a unique coded sensor. It sets calibration data, the nominal diameter and the sensor configuration - making the MagFlux® system ready to measure immediately. This avoids complicated and sensitive field calibrations and delicate electronic adjustments of the sensor, and allows unlimited interchanging of MagFlux® Converters and MagFlux® Flow Sensors.	
Counters for Flow in both Directions	The MagFlux® Converter has resettable and non-resettable counters for flow in both directions.  MagFlux® has two batch counters with smart-batch counting.	
Forward and Backwards Flow Measurement and Totalizing	The MagFlux® system measures flow in both directions and can totalize the net flow for both. A simple menu selection determines the primary flow direction.	
Data Logger	The MagFlux® built-in data logger can log up to 345.000 entries with time and date. Data is displayed graphically, but can also be exported to a PC via the USB port on the MagFlux® Display Unit.	
Field Link Easy-to-use Software	The MagFlux® PC connection allows exporting logged data to a PC, and importing new software updates. All through intuitive steps using a common USB port.	
Flexible In- and Outputs	The MagFlux® Converter has one 4-20 mA active analogue output, two digital outputs and one digital input. The digital input can stop and zero counter settings or control the batch counters manually. Each alarm can be displayed as a pop-up alarm until they are reset.	
Automatic Electrode Cleaning	The MagFlux® built-in electronic electrode cleaning system is always active.	
User Definable Text	The MagFlux® Display can be configured by the user for up to five lines of text. The graphic display is automatically adjusted to show the largest characters possible.	
Modbus® Communication	The display and converter uses the Modbus® communication protocol for internal and external communication.	

# MagFlux® Electromagnetic Flow Meter

## Electrical Connection

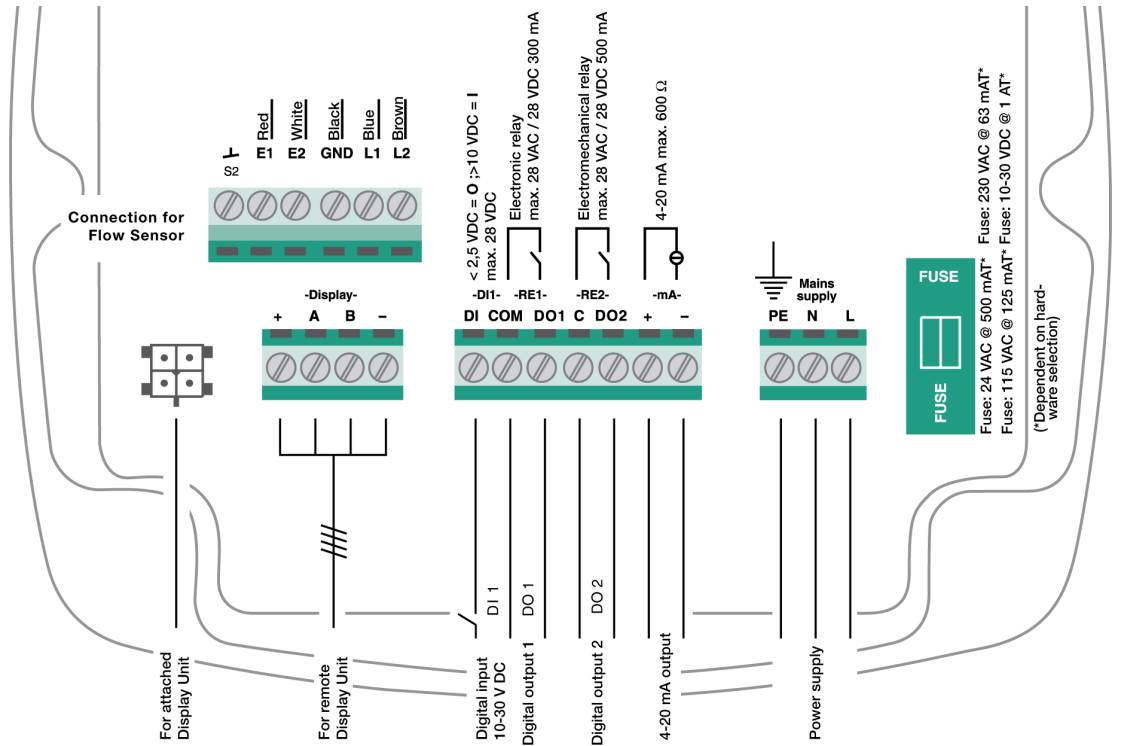

## Dimensions Millimeter

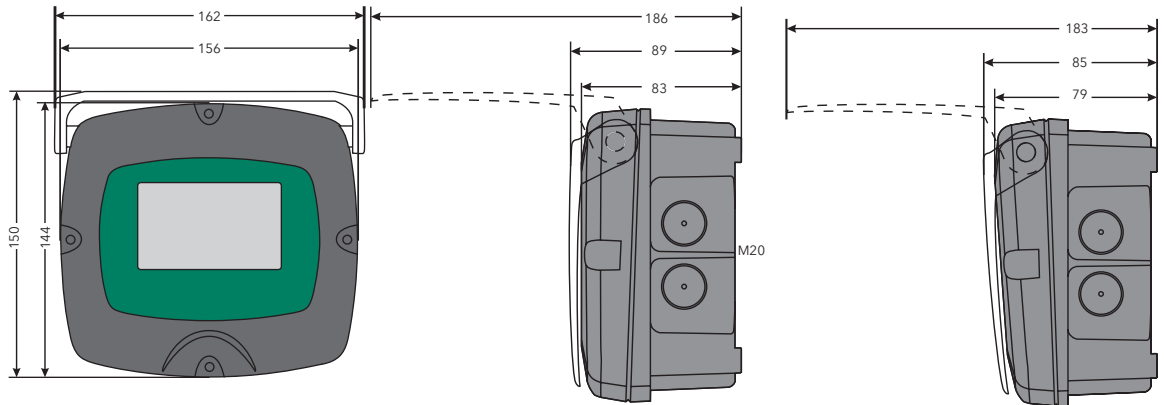

## Dimensions Inch

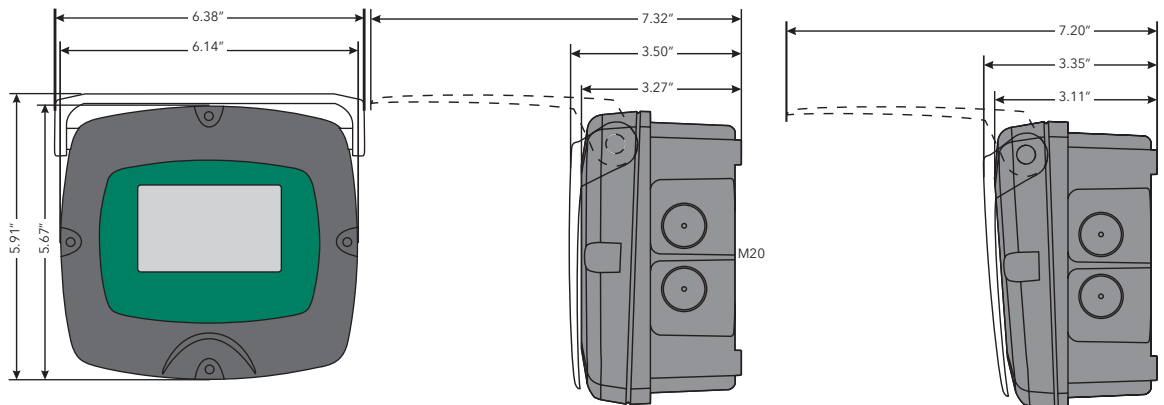

# MagFlux® Electromagnetic Flow Meter

## Accessories

579035  
MagFlux®  
Gel potting kit  
f/ sensor IP68

As standard, MagFlux® is supplied with protection class IP67. However, if you use our gel potting kit, you can increase the protection class to IP68 (which means that MagFlux® Sensor can withstand constant submersion in water (max. 10 m water column pressure).



207932  
Steel Cover for Field  
Cabinet (small)

Stainless steel protective cap and fittings set. Protects MagFlux®, Oxix and SuSix from falling objects, branches, etc. Stainless steel (SS316).



200242  
Mounting Plate,  
Field Cabinet (small)

Makes it possible to fit MagFlux® Converter to an uneven surface. Mounting plate is compatible with universal bracket. Can also be used to mount converter on pipe or stand.



207935  
Panel Mounting  
Bracket for MagFlux®,  
SuSix® & Oxix®

Bracket specially designed for narrow or wide converter cabinet. For fitting cabinet in panel front.

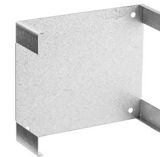

500220/500221  
Cover for Field Cabinet  
(small) Transparent/  
Opaque

Protects MagFlux® Display from strong sunlight/rain/contact.



205546  
Modbus® & RS 485  
Communications  
Module

To communicate with an external Modbus® network. For mounting in the MagFlux® Display. The MJK Modbus® Communication Module separates the internal network from the external network, e.g. to a PLC. The module can transmit data from four interconnected MJK transmitters.

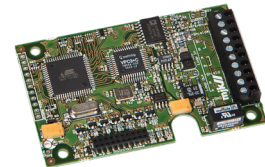

205547  
Profibus  
Communications  
Module

To communicate with an external PROFIBUS® network, we supply a Profibus DP module suitable for mounting in the MagFlux® Display. The MJK PROFIBUS® Communication Module can transmit data from four interconnected MJK transmitters.

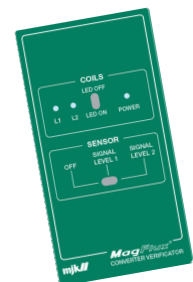

207980  
MagFlux® Verificator

MagFlux® Converter Verificator, simulates the coil and electrode functions of the MagFlux® Sensor for testing of the readings at zero and high flow rates on the converter.

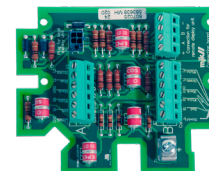

207937  
Surge Arresters for  
MagFlux®

Surge Arresters to protect converters and displays from lightning transmitted in pipes.

691080  
Cable for  
MagFlux® Sensor

(2x2+1) x 1.0mm<sup>2</sup> (AWG 18/19)  
Colours: Red, white, blue, brown, black PUR

691095  
USB Cable

PC Mini USB/USB cable



# MagFlux® Electromagnetic Flow Meter

## Specifications Converter and Display Unit

Display	
Display	Graphic background-lit LCD-display (64 x 128 pixels) with soft keys
Display Indication	Indication of flow , flow direction, volume, totalizers, configuration and graph
Power Supply	From MagFlux® Converter
Clock	Real-time clock with built-in lithium battery (lifetime 10 years@20°C)
Communication	MODBUS® RTU-mode, 9600 baud, 2-wire RS 485, master-mode
Interface	1 pcs. RS-485 Modbus® RTU-mode 1 pcs. USB 1,1 type mini B, female 1 pcs. for Communication module
Memory Storage	Flash memory, 345.000 loggings incl. date, time and value (curve display)
Enclosure Rating	IP 67, NEMA 6
Material	Housing: Glass-reinforced Polycarbonate Protection Lid: Transparent Polycarbonate
Temperature Range	- 20 ... 60 °C / -5 ... 150°F
Operating Relative Humidity	Max. 85% Noncondensing
Weight	0,5 kg / 1.1lb

Converter	
Accuracy	+/- 0,1% of reading
Repeatability	+/- 0,1%
Min. Liquid Conductivity	≥ 5 µS
Power Supply	24 V AC, 50 / 60 Hz ± 10 % or 230 (115) V AC, 50 / 60 Hz ± 10 % or 10-30 VDC
Power Consumption	Max. 10 W
Internal Communication	MODBUS® RTU-mode
External Communication	MODBUS® RTU-mode, 9600 baud, 2-wire RS 485, slave-mode
Interface	1 pcs. RS 485 for connection to Display Unit or PLC
Analog Output	1 pcs. Active 4 - 20 mA, galvanically isolated, 10 bit resolution, (max. load 600 Ω) <b>MagFlux® only:</b> Range = 0-10 m/s (0-32,80 ft/s) <b>MagFlux® Q only:</b> Range = 0-8 m/s (0-26,25 ft/s)
Digital Outputs	1 pcs. Voltage-free electromechanical relay (max. 28 VAC/ 28 VDC /500 mA) 1 pcs. Optically isolated MOSFET relay (max. 28 VAC/ 28 VDC /300 mA) Programmable for: Totalizer counter, batch counter, high/low flow, empty pipe and flow direction.
Digital Inputs	One, max. 28 V DC, < 2,5 V DC = 0 (low ), > 10 V DC = 1 (high), pulse length > 100 ms
Enclosure Rating	IP 67, NEMA 6
Material	Glass-reinforced Polycarbonate
Temperature Range	- 20 ... 60 °C / -5 ... 150°F
Weight	1,0 kg / 2.2lb
Approvals	cUL (only 115 VAC/230 VAC versions) CE approvals EN 61000-6-4:2007-02-14, EN 61000-6-2:2005-09-08

Connection Box	
Enclosure Rating	IP 68, NEMA 6X (using gel potting kit part no. 579035). The MagFlux® Flow Meter can withstand unlimited immersion of up to 10 m of water.
Material	Glass-reinforced Polycarbonate
Temperature Range	- 20 ... 100 °C / -5 ... 212°F

# MagFlux® Electromagnetic Flow Meter

## Order Numbers

MagFlux® Converter	
<b>Sensor mounted converter with display</b>	
207920	MagFlux® Converter w/display unit for sensor mounting 230VAC
297920	MagFlux® Converter w/ Display unit Sensor mounting 115VAC
207921	MagFlux® Converter w/display unit for sensor mounting, 24VAC
207922	MagFlux® Converter w/display unit for sensor mounting, 10-30VDC
<b>Sensor mounted converter without display</b>	
207910	MagFlux® Converter w/o display unit for sensor mounting 230VAC
297910	MagFlux® Converter w/o display sensor mounting, 115VAC
207911	MagFlux® Converter w/o display unit for sensor mounting, 24VAC
207912	MagFlux® Converter w/o display unit for sensor mounting, 10-30VDC
<b>Sensor wall mounted converter with display</b>	
207925	MagFlux® Converter w/display unit for wall mounting, 230VAC
297925	MagFlux® Converter w/ display unit for wall mounting 115VAC
207926	MagFlux® Converter w/display unit for wall mounting, 24VAC
207927	MagFlux® Converter w/display unit for wall mounting, 10-30VDC
<b>Sensor wall mounted converter without display</b>	
207928	MagFlux® Converter w/o display unit for wall mounting, 230VAC
297928	MagFlux® Converter w/o display unit for wall mounting, 115VAC
207929	MagFlux® Converter w/o display unit for wall mounting, 10-30VDC

Accessories	
106010	Cable mounting and potting of MagFlux® Sensor, incl. 579035 e. cable
109114	MID certificate for MagFlux 7200 DN25-DN400
200062	Complete MagFlux® cabinet with blind lid, sensor mounted
200242	Mounting plate, Field Cabinet (small)
205546	Modbus and RS 485 communications module
205547	Profibus DP communication module
207930	Wall mounting kit for MagFlux®, SuSix® and Oxix®
207932	Steel Cover for Field cabinet (small)
207935	Panel Mounting Bracket for MagFlux®, SuSix® and Oxix®
207936	Panel Mounting Bracket for wide Cabinet
207937	Surge Arrester for MagFlux® for wall mounting
207938	Surge Arrester for MagFlux® for sensor mounting
207940	Display Unit for MagFlux®, SuSix®, Oxix®
207980	MagFlux® Converter Verificator
500220	Cover for Field Cabinet (small) transparent
500221	Cover for Field Cabinet (small) Opaque
571025	Packing 65 / 40mm for MagFlux QUAD PORON11 3.2mm m. mounting tape (only MagFlux® Q)
579035	MagFlux® Gel potting kit f/ sensor IP68 NEMA6P
691075	Communication cable 2X2X0,5mm2 (AWG24) Shielded twisted pair
691080	Cable for MagFlux® sensor, pr m
691095	PC Mini USB/USB Cable
691098	USB mini/USB mini, plug for cabinet 0,2m cable
840110	MJK Field-Link

# MagFlux® Electromagnetic Flow Meter

Flow Sensor  
Ordering  
Information



<p>Type of flange (Fit for Wafer): _____</p> <p>20: EN-1092-1 24: KSD4308 25: KSD3578 26: JIS B2220/KS B1503 / KS D4308 28: AS 4087-2004 &amp; AS 2129-2000 29: ANSI B16.5 ½"-24"/AWWA C207-01 28"-54"</p> <p>Series information: _____</p> <p>71: 7100 Flanged PTFE/PFA 72: 7200 Flanged Hard rubber 73: 7300 Wafer PTFE/PFA 82: 8200 Flanged ABS</p> <p>Size: _____</p> <p>ID for identifying the size. (2071XX) See Order numbers table</p>	<p>20    72    31    - 016 - 00</p>	<p>Material - Electrodes:</p> <p>x0: Stainless steel 316Ti (default) x1: Hastelloy C electrode x2: Titanium electrode x3: Platinum irridium alloy electrode</p> <p>Material - Housing and flanges:</p> <p>0x: Housing and Flanges, painted Carbon steel (default) 1x: Housing and flanges, polished stainless steel 316 2x: Housing and flanges, polished stainless steel 304, 3x: Housing polished stainless steel 304, flanges painted carbon steel 4x: Housing and Flanges, ABS 9x: Housing polished stainless steel 316 flanges painted carbon steel</p> <p>Pressure class:</p> <p>if EN use PN (e.g. 016 for PN16) if KS use PN (e.g. 016 for PN16) if AS use PN (e.g. 016 for PN16) if ANSI use psi (e.g. 150 for psi150) if AWWA use psi (e.g. Class D for psi150)</p>
--	-------------------------------------	---

Also try our online MagFlux® sensor configurator:  
<http://magflux.dk/> which can help you select the  
correct MagFlux® Flow Meter for you needs.

# MagFlux® Electromagnetic Flow Meter

Dimensions  
Magflux®  
7100/7200  
Sensor  
EN 1092-1

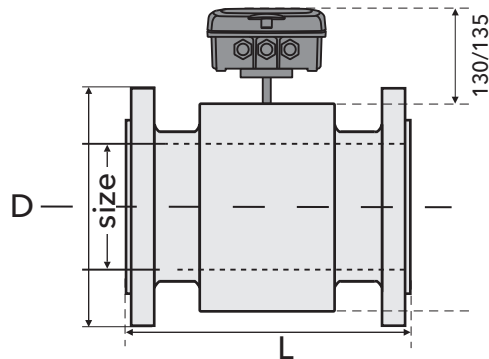

Dimensions

Magflux® 7100/7200 Sensor Sizes and Dimensions Information					
Size	Pressure	D	L	Weight	
DN	PN	[mm]	[mm]	[kg]	
EN 1092-1 Flanges					
15	½"	40	95	200	3,5
20	¾"	40	105	200	3,5
25	1"	40	115	200	3,5
32	1¼"	40	140	200	6
40	1½"	40	150	200	7
50	2"	16	165	200	8
65	2½"	16	185	200	10
80	3"	16	200	200	12
100	4"	16	220	250	16
125	5"	16	250	250	21
150	6"	16	285	300	28
200	8"	16	340	350	35
250	10"	10	395	450	43
300	12"	10	445	500	55
350	14"	10	505	550	66
400	16"	10	565	600	94
450	18"	10	615	600	105
500	20"	10	670	600	122
600	24"	10	780	600	158
700	28"	10	895	700	230
800	32"	6	975	800	325
900	36"	6	1075	900	420
1000	40"	6	1175	1000	510
1200	48"	6	1405	1200	680
1400		6	1630	1400	

Consult MJK for information on additional pressure classes

# MagFlux® Electromagnetic Flow Meter

Dimensions  
Magflux®  
7100/7200  
Sensor  
AS 2129 & 4087

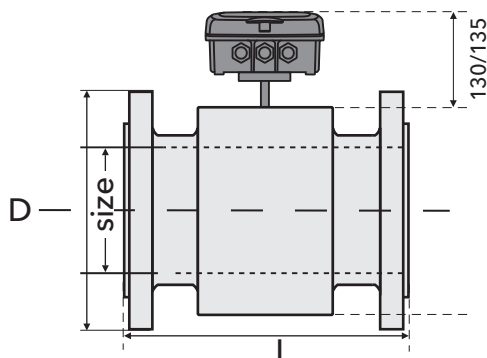

Magflux® 7100/7200 Sensor Sizes and Dimensions Information					
Size	Pressure	D	L	Weight	
DN	PN	[mm]	[mm]	[kg]	
AS 2129 Flanges					
15	½"	PN16	95	200	3,5
20	¾"	PN16	100	200	3,5
25	1"	PN16	115	200	3,5
32	1¼"	PN16	120	200	6
40	1½"	PN16	135	200	7

Consult MJK for information on additional pressure classes

Magflux® 7100/7200 Sensor Sizes and Dimensions Information					
Size	Pressure	D	L	Weight	
DN	PN	[mm]	[mm]	[kg]	
AS 4087 Flanges					
50	2"	14	150	200	8
65	2½"	14	165	200	10
80	3"	16	185	200	12
100	4"	16	215	250	16
125	5"	16	255	250	21
150	6"	16	280	300	28
200	8"	16	335	350	35
225		16	370	450	38
250	10"	16	405	450	43
300	12"	16	455	500	55
350	14"	16	525	550	66
375		16	550	600	70
400	16"	16	580	600	94
450	18"	16	640	600	105
500	20"	16	705	600	122
600	24"	16	825	600	158
700	28"	16	910	700	230
750	30"	16	995	750	275
750*	30"	16	937	750	275
800	32"	16	1060	800	325
900	36"	16	1175	900	420
1000	40"	16	1255	1000	510
1200	48"	16	1490	1200	680

Consult MJK for information on additional pressure classes

\*) Built-in length, L=937mm

# MagFlux® Electromagnetic Flow Meter

Dimensions  
Magflux®  
7100/7200  
Sensor  
ANSI & AWWA

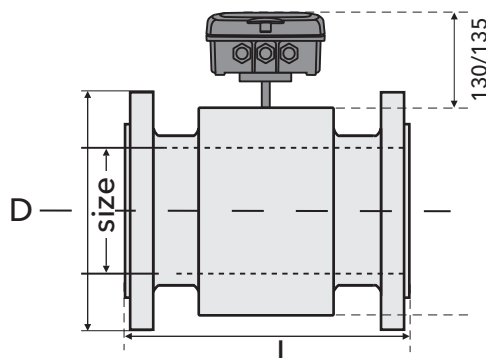

**Magflux® 7100/7200 Sensor Flanges  
Sizes, Pressure and Dimensions Information**

Size	Pressure	D	L	Weight
Inch	[PSI]	[in]	[in]	[lb]
<b>ANSI B 16.5</b>				
½"	150	3.50	7.9	8
¾"	150	3.88	7.9	8
1"	150	4.25	7.9	8
1¼"	150	4.62	7.9	13
1½"	150	5.00	7.9	15
2"	150	6.00	7.9	18
2½"	150	7.00	7.9	22
3"	150	7.50	7.9	26
4"	150	9.00	9.8	35
5"	150	10.00	9.8	46
6"	150	11.00	11.8	62
8"	150	13.50	13.8	77
10"	150	16.00	17.7	95
12"	150	19.00	19.7	121
14"	150	21.00	21.7	146
16"	150	23.50	23.6	207
18"	150	25.00	23.6	231
20"	150	27.50	23.6	269
24"	150	32.00	23.6	348
<b>AWWA C207-01</b>				
28"	Class D	36.50	23.6	507
32"	Class D	41.75	31.5	717
36"	Class D	46.00	31.5	926
40"	Class D	50.75	31.5	1124
48"	Class D	59.50	39.4	1499

Consult MJK for information on additional pressure classes

**Magflux® 7100/7200 Sensor Flanges  
Sizes, Pressure and Dimensions Information**

Size	Pressure	D	L	Weight
Inch	[PSI]	[in]	[in]	[lb]
<b>ANSI B 16.5</b>				
½"	300	3.75	7.9	8
¾"	300	4.62	7.9	8
1"	300	4.88	7.9	8
1¼"	300	5.25	7.9	13
1½"	300	6.12	7.9	15
2"	300	6.50	7.9	18
2½"	300	7.50	7.9	22
3"	300	8.25	7.9	26
4"	300	10.00	9.8	35
5"	300	11.00	9.8	46
6"	300	12.50	11.8	62
8"	300	15.00	13.8	77
10"	300	17.50	17.7	95
12"	300	20.50	19.7	121
14"	300	23.00	21.7	146
16"	300	25.50	23.6	207
18"	300	28.00	23.6	231
20"	300	30.50	23.6	269
24"	300	36.00	23.6	348
<b>AWWA C207-01</b>				
28"	Class E	36.50	23.6	507
32"	Class E	41.75	31.5	717
36"	Class E	46.00	31.5	926
40"	Class E	50.75	31.5	1124
48"	Class E	59.50	39.4	1499

Consult MJK for information on additional pressure classes

# MagFlux® Electromagnetic Flow Meter

## MagFlux® 7100 Sensor



The liner of MagFlux® 7100 is PTFE/PFA, which offers an extremely low degree of friction and, at the same time, makes it very resistant to chemicals and general abrasion.

### Applications

MagFlux® 7100 with PTFE/PFA liner is commonly used for water applications with:

- chemicals
- paper & pulp
- high temperature installations.

### Specifications MagFlux® 7100 Sensor

MagFlux® 7100 Sensor Specifications	
Mounting Flanges ①	EN-1092-1 / ANSI B 16.5 / AWWA C207-01 / AS 4087 / AS2129
Built-in Length	Standard length according to EN/ISO 20456:2019
Accuracy ②	Better than $\pm 0,25\%$ @ 0,2 - 10 m/s
Ratio	1:100
Measuring Frequency	1,25-2,5 Hz
Materials	
Housing ①	Carbon steel
Flanges ①	Carbon steel
Measuring Pipe	Steel 1.4301 / AISI 304
Lining	PTFE (Teflon®)/PFA
Electrodes ③④	Steel 1,4571 / AISI 316 TI
Coating	3 layers Polyurethane paint, thickness $\geq 310 \mu\text{m}$
Temperature Range	
Medium Temperature	-20...150 °C / -4...300 °F
Ambient Temperature	
Sensor:	
Compact Converter	-20.....60 °C / 15..140 °F
Remote Converter	-20...100 °C / -4...212 °F
Enclosure	IP 67, NEMA 4, standard IP 68, NEMA 6P (10m Wc, using the Gel potting kit 579035)
①Also available in Steel 304/316 SS. See MagFlux® Flow Sensor Ordering information.	
②Of measured value.	
③Options: Hastelloy C4, platinum, and titanium. See MagFlux® Flow Sensor Ordering information.	
④Incl. built in ground electrode.	

# MagFlux® Electromagnetic Flow Meter



Sizes, Pressure and Order Numbers  
7100 Sensor  
EN 1092-1

Magflux® 7100 Sensor - Sizes, Pressure and Order Number					
EN 1092-1 Flanges					
Size \ PN	PN6	PN10	PN16	PN25	PN40
DN 15					207107-040-00
DN 20					207110-040-00
DN 25					207113-040-00
DN 32					207116-040-00
DN 40					207119-040-00
DN 50			207122-016-00		207122-040-00
DN 65			207125-016-00		207125-040-00
DN 80			207128-016-00		207128-040-00
DN 100			207131-016-00		207131-040-00
DN 125			207134-016-00		207134-040-00
DN 150			207137-016-00	207137-025-00	207137-040-00
DN 200		207140-010-00	207140-016-00	207140-025-00	207140-040-00
DN 250		207143-010-00	207143-016-00	207143-025-00	207143-040-00
DN 300		207146-010-00	207146-016-00	207146-025-00	207146-040-00
DN 350		207149-010-00	207149-016-00	207149-025-00	207149-040-00
DN 400		207152-010-00	207152-016-00	207152-025-00	207152-040-00
DN 450		207155-010-00	207155-016-00		
DN 500		207158-010-00	207158-016-00		
DN 600		207161-010-00	207161-016-00		
DN 700	207164-006-00	207164-010-00	207164-016-00		
DN 800	207167-006-00	207167-010-00	207167-016-00		
DN 900	207170-006-00	207170-010-00			
DN 1000	207172-006-00	207172-010-00			

Sizes, Pressure and Order Numbers  
7100 Sensor  
ANSI & AWWA

Magflux® 7100 Sensor Sizes, Pressure and Order Number		
ANSI B 16.5 Flange		
Size \ PSI	150 [PSI]	300 [PSI]
½"	297107-150-00	297107-300-00
¾"	297110-150-00	297110-300-00
1"	297113-150-00	297113-300-00
1¼"	297116-150-00	297116-300-00
1½"	297119-150-00	297119-300-00
2"	297122-150-00	297122-300-00
2½"	297125-150-00	297125-300-00
3"	297128-150-00	297128-300-00
4"	297131-150-00	297131-300-00
5"	297134-150-00	297134-300-00
6"	297137-150-00	297137-300-00
8"	297140-150-00	297140-300-00

Magflux® 7100 Sensor Sizes, Pressure and Order Number		
ANSI B 16.5 Flange		
Size \ PSI	150 [PSI]	300 [PSI]
10"	297143-150-00	297143-300-00
12"	297146-150-00	297146-300-00
14"	297149-150-00	297149-300-00
16"	297152-150-00	297152-300-00
18"	297155-150-00	297155-300-00
20"	297158-150-00	297158-300-00
24"	297161-150-00	297161-300-00
AWWA C207-01	Class D	Class E
28"	297164-150-00	297164-300-00
32"	297167-150-00	297167-300-00
36"	297170-150-00	297170-300-00
40"	297173-150-00	

# MagFlux® Electromagnetic Flow Meter

## MagFlux® 7200 Sensor



The liner of MagFlux® 7200 is hard rubber for general water purpose usage.

### Applications



MagFlux® 7200 with hard rubber lining is an all-round sensor for water and wastewater applications.

### Specifications MagFlux® 7200 Sensor

MagFlux® 7200 Sensor Specifications	
Mounting Flanges ①	EN-1092-1 / ANSI B 16.5 / AWWA C207-01 / AS 4087 / AS 2129
Built-in Length	Standard length according to EN/ISO 20456:2019
Accuracy ②	Better than $\pm 0,25\%$ @ 0,2 - 10 m/s
Ratio	1:100
Measuring Frequency	1,25-2,5 Hz
Materials	
Housing ①	Carbon steel
Flanges ①	Carbon steel
Measuring Pipe	Steel 1.4301 / AISI 304
Lining	Hard Rubber
Electrodes ③④	Steel 1,4571 / AISI 316 TI
Coating	3 layers Polyurethane paint, thickness $\geq 310 \mu\text{m}$
Temperature Range	
Medium Temperature	-10...80 °C / 15...175 °F
Ambient Temperature Sensor:	
Compact Converter	-10...60 °C / 15...140 °F
Remote Converter	-10...80 °C / 15...175 °F
Enclosure	IP 67, NEMA 4, standard IP 68, NEMA 6P (10m Wc, using the Gel potting kit 579035)
Approvals	MID and MCERTS EN 1092-1 DN 25 to 400 , WRAS
①Also available in Steel 304/316 SS. See MagFlux® Flow Sensor Ordering information.	
②Of measured value.	
③Options: Hastelloy C4, platinum, and titanium. See MagFlux® Flow Sensor Ordering information.	
④Incl. built-in ground electrode.	



# MagFlux® Electromagnetic Flow Meter

Sizes, Pressure and Order Numbers  
7200 Sensor  
EN 1092-1

EN 1092-1 Flanges						
Size \ PN	PN6	PN10	PN16	PN25	PN40	
20	¾"					207210-040-00
25	1"					207213-040-00
32	1¼"					207216-040-00
40	1½"					207219-040-00
50	2"			207222-016-00		207222-040-00
65	2½"			207225-016-00		207225-040-00
80	3"			207228-016-00		207228-040-00
100	4"			207231-016-00		207231-040-00
125	5"			207234-016-00		207234-040-00
150	6"			207237-016-00	207237-025-00	207237-040-00
200	8"		207240-010-00	207240-016-00	207240-025-00	207240-040-00
250	10"		207243-010-00	207243-016-00	207243-025-00	207243-040-00
300	12"		207246-010-00	207246-016-00	207246-025-00	207246-040-00
350	14"		207249-010-00	207249-016-00	207249-025-00	207249-040-00
400	16"		207252-010-00	207252-016-00	207252-025-00	207252-040-00
450	18"		207255-010-00	207255-016-00		
500	20"		207258-010-00	207258-016-00		
600	24"		207261-010-00	207261-016-00		
700	28"	207264-006-00	207264-010-00	207264-016-00		
800	32"	207267-006-00	207267-010-00	207267-016-00		
900	36"	207270-006-00	207270-010-00	207270-016-00		
1000	40"	207272-006-00	207272-010-00			
1200	48"	207276-006-00	207276-010-00			
1400		287278-006-00				

Sizes, Pressure and Order Numbers  
7200 Sensor  
ANSI & AWWA

Magflux® 7200 Sensor Sizes, Pressure and Order Number			
ANSI B 16.5 Flange			
Size \ PSI	150 [PSI]	300 [PSI]	
½"	297107-150-00	297107-300-00	
¾"	297210-150-00	297110-300-00	
1"	297213-150-00	297113-300-00	
1¼"	297216-150-00	297116-300-00	
1½"	297219-150-00	297119-300-00	
2"	297222-150-00	297222-300-00	
2½"	297225-150-00	297225-300-00	
3"	297228-150-00	297228-300-00	
4"	297231-150-00	297231-300-00	
5"	297234-150-00	297234-300-00	
6"	297237-150-00	297237-300-00	
8"	297240-150-00	297240-300-00	

Magflux® 7200 Sensor Sizes, Pressure and Order Number			
ANSI B 16.5 Flange			
Size \ PSI	150 [PSI]	300 [PSI]	
10"	297243-150-00	297243-300-00	
12"	297246-150-00	297246-300-00	
14"	297249-150-00	297249-300-00	
16"	297252-150-00	297252-300-00	
18"	297255-150-00	297255-300-00	
20"	297258-150-00	297258-300-00	
24"	297261-150-00	297261-300-00	
AWWA C207-01	Class D	Class E	
28"	297264-150-00	297264-300-00	
32"	297267-150-00	297267-300-00	
36"	297270-150-00	297270-300-00	
40"	297273-150-00	297273-300-00	

# MagFlux® Electromagnetic Flow Meter

Sizes, Pressure and  
Order Numbers  
7200 Sensor  
AS 2129 & AS 4087

AS 2129 Flanges			
Size	PN16	PN21	PN35
15	287207-016-00		
20	287210-016-00	287210-021-00	
25	287213-016-00	287213-021-00	
32	287216-016-00	287216-021-00	
40	287219-016-00		
AS 4087 Flanges			
50	287222-016-00	287222-021-00	287222-035-00
65	287225-016-00	287225-021-00	287225-035-00
80	287228-016-00	287228-021-00	287228-035-00
100	287231-016-00	287231-021-00	287231-035-00
125	287234-016-00	287234-021-00	287234-035-00
150	287237-016-00	287237-021-00	287237-035-00
200	287240-016-00	287240-021-00	287240-035-00
225	287241-016-00		
250	287243-016-00	287243-021-00	287243-035-00
300	287246-016-00	287246-021-00	287246-035-00
350	287249-016-00	287249-021-00	287249-035-00
375	287250-016-00		
400	287252-016-00	287252-021-00	287252-035-00
450	287255-016-00	287255-021-00	287255-035-00
500	287258-016-00	287258-021-00	287258-035-00
600	287261-016-00	287261-021-00	287261-035-00
700	287264-016-00	287264-021-00	
750	287265-016-00	287265-021-00	
750*	287266-016-00		
800	287267-016-00		
900	287270-016-00		
1000	287273-016-00		
1200	287276-016-00		

\*) build-in length, L=937mm

# MagFlux® Electromagnetic Flow Meter

## MagFlux® 7300 Sensor



The liner of MagFlux® 7300 is PTFE/PFA, which offers an extremely low degree of friction and, at the same time, makes it very resistant to chemicals and general abrasion.

### Applications

MagFlux® 7300 with PTFE/PFA liner is commonly used for water applications with:

- chemicals
- paper & pulp
- high temperature installations
- installations on pipe systems where the sensor is installed between existing flanges in order to reduce the cost of the installation.

### Specifications MagFlux® 7300 Sensor

MagFlux® 7300 Sensor Specifications	
Mounting	Wafer
Accuracy ①	Better than $\pm 0,25\%$ @ 0,2 - 10 m/s
Ratio	1:100
Measuring Frequency	2,5 Hz
<b>Materials</b>	
Housing ②	Carbon steel
Measuring Pipe	Steel 1.4301 / AISI 304
Lining	PTFE (Teflon®) / PFA
Electrodes ③④	Steel 1,4571 / AISI 316 TI
Coating	5 layers Polyurethane paint, thickness $\geq 310 \mu\text{m}$
<b>Temperature range</b>	
Medium Temperature	-20...150 °C / -4...300 °F
Ambient Temperature sensor:	
Compact Converter	-20.....60 °C / 15..140 °F
Remote Converter	-20...100 °C / -4...212 °F
Enclosure	IP 67, NEMA 4, standard IP 68, NEMA 6P (10m Wc, using the Gel potting kit 579035)
①Of measured value. ②Also available in Steel 304/316 SS. See MagFlux® Flow Sensor ordering information. ③Options: Hastelloy C4, platinum, and titanium. See MagFlux® Flow Sensor ordering information. ④Incl. built-in ground electrode.⑥	

# MagFlux® Electromagnetic Flow Meter

Dimensions  
Magflux® 7300  
Sensor

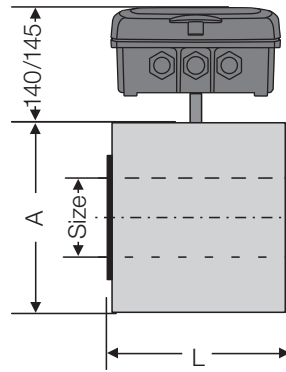

Dimensions

Magflux® 7300 Sensor - Sizes and Dimensions Information					
Size		Pressure	A	L	Weight
DN	[inch]	PN	[mm]	[mm]	[kg]
15	1/2"	40	62	74	1,1
20	3/4"	40	62	74	1,1
25	1"	40	72	104	1,5
32	1 1/4"	40	82	104	1,8
40	1 1/2"	40	92	104	2,2
50	2"	16	107	104	2,8
65	2 1/2"	16	127	104	3,2
80	3"	16	142	104	3,5
100	4"	16	162	104	4
125	5"	16	192	134	6
150	6"	16	218	134	8
200	8"	16	274	219	10

Sizes, Pressure and  
Order Numbers  
7300 Sensor

Magflux® 7300 Sensor - Sizes, Pressure and Order Number			
	PN10	PN16	PN40
DN 15		207307-016-00	207307-040-00
DN 20		207310-016-00	
DN 25		207313-016-00	
DN 32		207316-016-00	
DN 40		207319-016-00	
DN 50		207322-016-00	
DN 65		207325-016-00	
DN 80		207328-016-00	
DN 100		207331-016-00	
DN 125		207334-016-00	
DN 150		207337-016-00	
DN 200	207340-010-00	207340-016-00	

# MagFlux® Electromagnetic Flow Meter

## MagFlux® 8200 Q Sensor



The entire MagFlux® 8200 Q Sensor is made of ABS (composite material) which is ideal for seawater applications, e.g. aquaculture and desalination plants. Here, it is essential that it has no outer parts in metal as this offers high corrosion resistance. As a standard, the sensor is delivered with Hastelloy C electrodes. Due to the unique design of the flow tube, MagFlux® 8200 Q has very high accuracy at low flow speed. Finally, its range covers DN 50-80-100-150, all in PN16.

### Applications

MagFlux® 8200 Q is typically used in saline and/or seawater installations and is perfect for district wells where the high accuracy is optimal for night flow measurement which can help eliminate even minor water leaks.

### Specifications MagFlux® 8200 Q Sensor

MagFlux® Q Sensor Specifications	
Mounting Flanges	Compatible with EN1092-1
Built-in Length	Standard length according to EN/SO 20456:2019
Accuracy ①	Better than $\pm 0,25\%$ @ 0,2-8 m/s
Ratio	0,5-100
Measuring Frequency	2,5 Hz
Materials	
Housing	ABS
Flanges	ABS
Measuring Pipe	ABS
Lining	ABS
Electrodes ②	Hastelloy C
Temperature Range	
Medium Temperature	-20...80 °C / -4...176 °F
Ambient Temperature: Compact Converter	-10...60 °C / 15...140 °F
Remote Converter	-20...80 °C / -4...176 °F
Enclosure	IP 67, NEMA 4, standard IP 68, NEMA 6P (10m Wc, using the Gel potting kit 579035) - Remote Converter
① Of measured value.	
② Electrodes ONLY available in Hastelloy Incl. built in ground electrode.	

Dimensions  
Magflux® 8200  
Q Sensor ABS

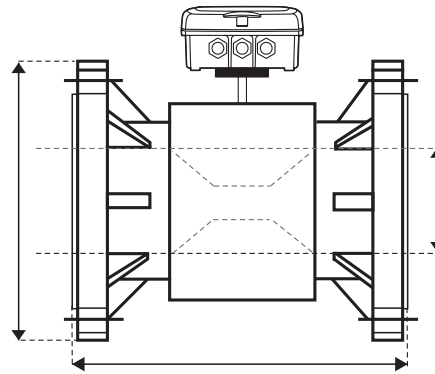

Dimensions

Magflux® 8200 Q Sensor Sizes and Dimensions Information							
Size		Pressure	D	L	Weight	Qmin	Qmax
DN		PN	[mm]	[mm]	[kg]	0,2 m/s	8 m/s
EN 1092-1 Flanges						m <sup>3</sup> /h	
50	2"	16	165	200	3,8	1,2	55
80	3"	16	200	200	5	3,6	145
100	4"	16	220	250	6,8	6	225
150	6"	16	285	300	9,2	12	500

Order Numbers  
MagFlux® 8200  
Q Sensor

Sensor	
208222-016-41	MagFlux® Q 8200 Sensor ABS DN50 EN/PN16 Hastelloy C
208228-016-41	MagFlux® Q 8200 Sensor ABS DN80 EN/PN16 Hastelloy C
208231-016-41	MagFlux® Q 8200 Sensor ABS DN100 EN/PN16 Hastelloy C
208237-016-41	MagFlux® Q 8200 Sensor ABS DN150 EN/PN16 Hastelloy C

# MagFlux® Electromagnetic Flow Meter

## Grounding Rings

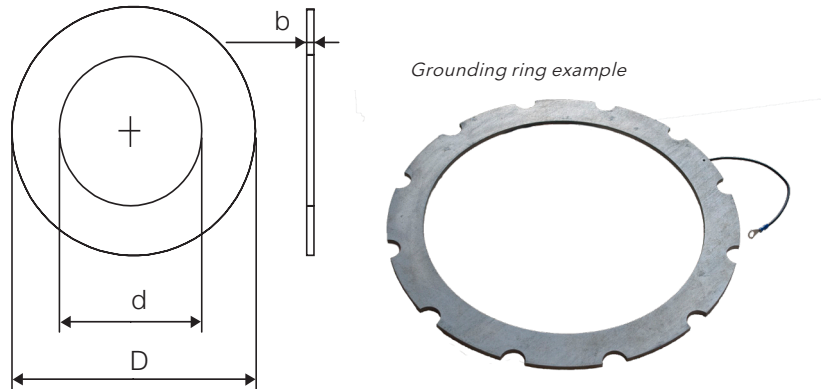

## Sizes and Ordering Information

Grounding Rings Sizes and Ordering Information						
DN	Size		D <sup>①</sup>	d	b	Weight
	[inch]	Order no.				
15	½"	207807	50	22	6	0,08
20	¾"	207810	58	28	6	0,08
25	1"	207813	68	35	6	0,12
32	1¼"	207816	79	43	6	0,16
40	1½"	207819	91	49	6	0,20
50	2"	207822	106	61	6	0,26
65	2½"	207825	126	77	6	0,40
80	3"	207828	141	90	6	0,44
100	4"	207831	170	115	6	0,56
125	5"	207834	191	141	6	0,60
150	6"	207837	237	170	6	0,90
200	8"	807840	272	220	6	0,96
250	10"	207843	333	274	6	1,30
300	12"	807846	405	325	6	2,00
350	14"	207849	443	360	6	2,48
400	16"	207852	521	411	6	3,60
450	18"	207855	546	463	6	3,20
500	20"	207858	602	514	6	3,64
600	24"	207861	713	615	6	4,70
700	28"	207862				
750	30"	207863				
800	32"	207867				

① maximum measurement

## Specifications

Grounding Rings Specifications	
Material	AISI 316 SS
Wire	2,5 mm <sup>2</sup> / AWG 13

# MagFlux® Electromagnetic Flow Meter



## Flow Sensor Sizing

Min. / Max. Flow and Default mA Settings				
Size		Qmin = 0,2 m/s	Qmax= 10 m/s	20 mA
DN	[inch]	[l/h]		
15	½"	127	6362	5000
20	¾"	226	11304	10000
25	1"	353	17676	20000
32	1 ¼"	578	28944	30000
40	1 ½"	905	45360	50000
50	2"	1414	70560	75000
-	-	[m³/h]	[m³/h]	[m³/h]
65	2 ½"	2,39	119	100
80	3"	3,62	181	200
100	4"	5,65	283	300
125	5"	8,84	442	400
150	6"	12,7	636	600
200	8"	22,6	1131	1000
250	10"	35,3	1767	2000
300	12"	50,9	2545	2500
350	14"	69,3	3464	3000
400	16"	90,5	4524	4500
450	18"	115	5726	6000
500	20"	141	7069	7000
600	24"	204	10179	10000
700	28"	277	13854	15000
800	32"	362	18095	20000
900	36"	458	22902	25000
1000	40"	565	28274	30000
1200	48"	814	40715	40000

Min and Max Flow Imperial		
Size	Qmin 0.6 ft./s	Qmax 30 ft./s
[inch]	[GPM]	
½"	0.559	28.0
¾"	0.995	49.76
1"	1.550	77.82
1 ¼"	2.549	127.4
1 ½"	3.984	199.7
2"	6.226	310.7
2 ½"	10.52	523.9
3"	15.93	796.9
4"	24.87	1246
5"	38.92	1946
6"	55.91	2800
8"	99.50	4,979
10"	155.4	7,780
12"	224.1	11,205
14"	305.1	15,258
16"	398.5	19,919
18"	506.3	25,210
20"	620.8	31,120
24"	999.1	44,910
28"	1220	74,920
32"	1594	79,620
36"	2017	100,800
40"	2497	124,500
48"	3584	179,300

20mA output is factory preset to Qmax

To calculate the correct size of the MagFlux® Flow Sensor the recommended flow velocity should be between 1 and 3 m/s (3 and 10 ft/s). The flow

curves and graphs on the following page illustrate how the size of the MagFlux® Flow Sensor is calculated to get the required measuring accuracy.

### Example:

A volume of 50 m³/h (220 GPM) is running through a DN100 pipe that measures 4" in internal diameter. To select the correct MagFlux® Flow Sensor, the liquid velocity should be in the range 1 - 3 m/s for 50 m³/h (3 ft/s - 10 ft/s for 220 GPM.)

If a MagFlux® Flow Sensor with the same inner

diameter as the DN100 pipe is selected (4"), the flow velocity will be 1.5 m/s (4.9 ft/s) at a flow rate of 42 m³/h (200 GPM). The diagram and the table in the following also shows that a flow between 5.65 m³/h and 283 m³/h (24.87 and 1.246 kGPM) can be measured.

# MagFlux® Electromagnetic Flow Meter

## Flow / Velocity Graph (metric)

Nominal diameter of MagFlux® Flow Sensor

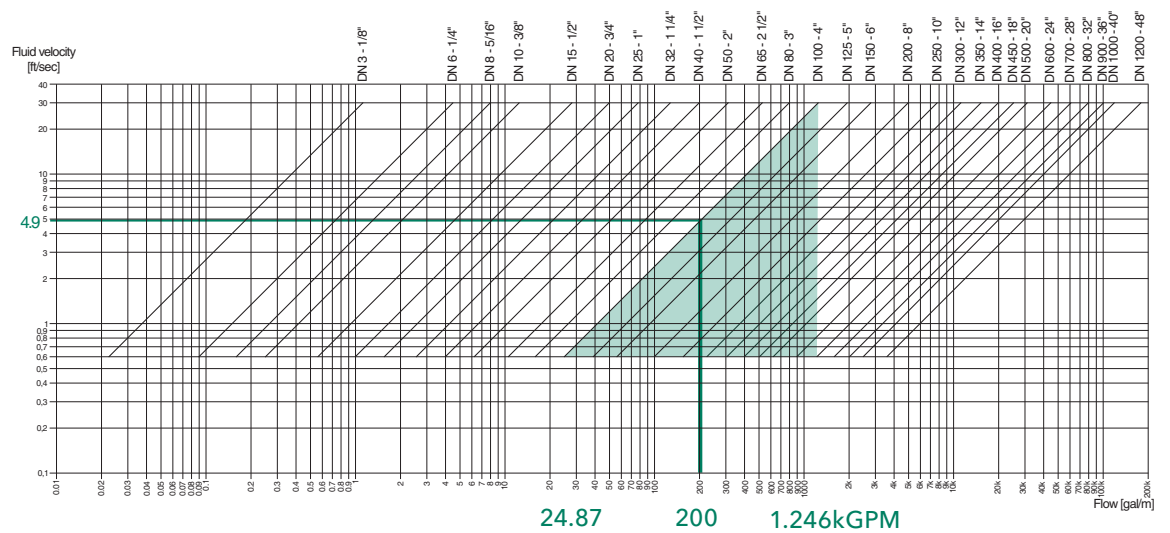
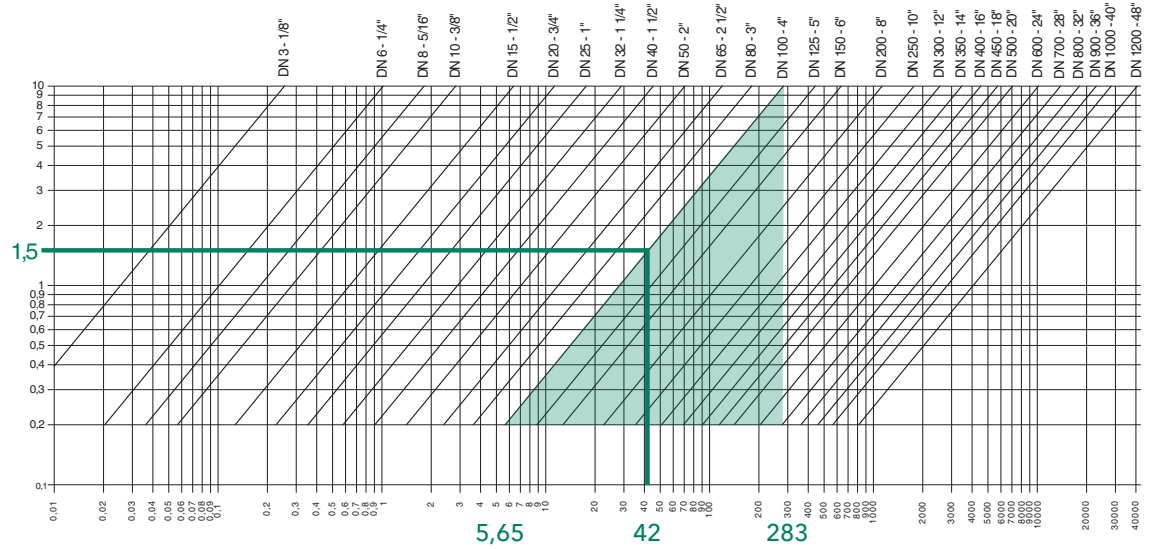

## Measurement Accuracy

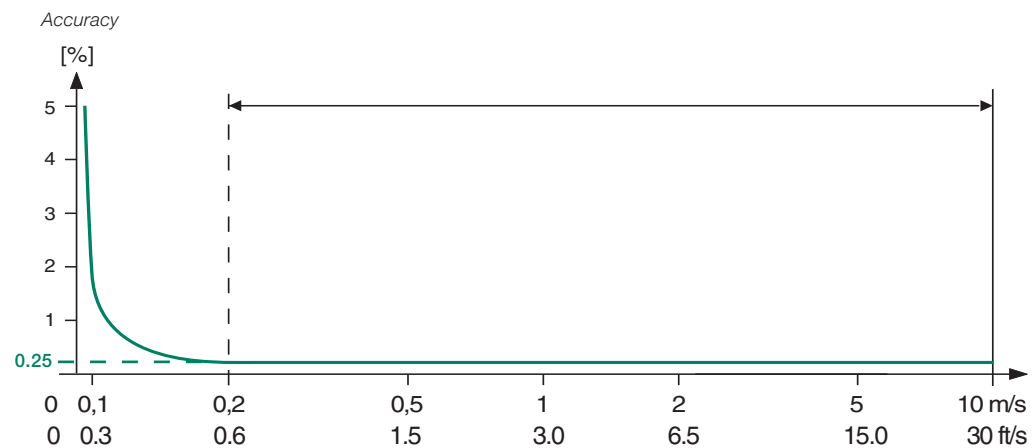

### Example:

If a 100 mm MagFlux® Flow Sensor is selected, the diagram shows the available measuring accuracy between 0.2 - 10 m/s or 0.6 - 30 ft/s (here: 0.25%).

# MagFlux® Electromagnetic Flow Meter

## Reducing the Flow Meter Size

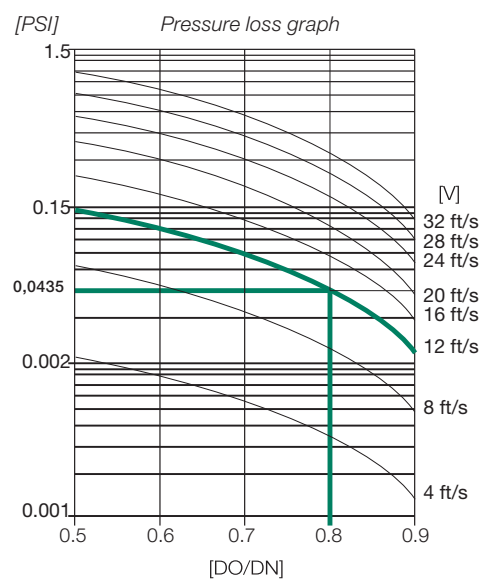
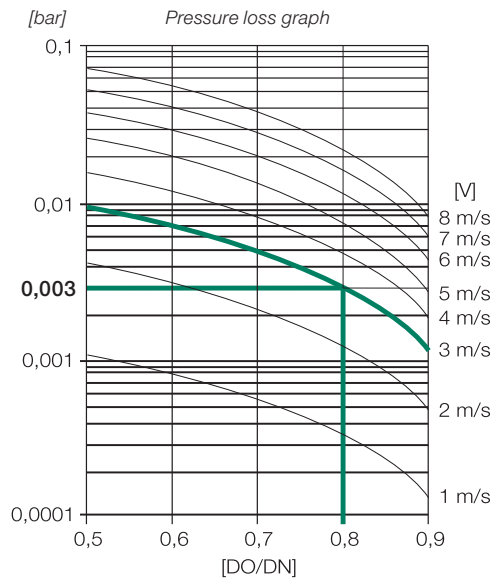

When the size of the MagFlux® Flow Meter is reduced to cause the flow to reach a sufficient velocity, the pipe size has to be reduced. This will cause a pressure loss which can be calculated

using the pressure loss graph at the right. When the MagFlux® Sensor is smaller than nominal pipe diameter, the pressure loss can be checked, using the pressure loss chart.

## Reducing the Flow Meter Size

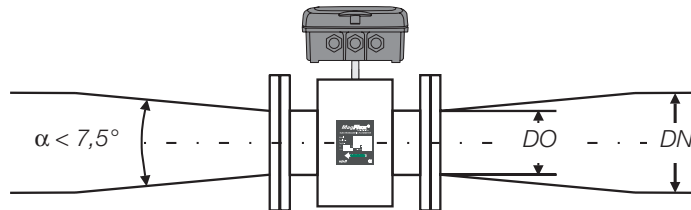

A MagFlux® Flow Sensor with an internal diameter of 80 mm is selected and the pipe size is 100 mm. Consequently, the fluid velocity for a flow of approximately 50m<sup>3</sup>/h will increase to approximately 3 m/s. Using a DN80 mm MagFlux®

Flow Sensor also leads to a smaller measurement range (3.62 m<sup>3</sup>/h - 181 m<sup>3</sup>/h). The diagram shows that reducing the pipe size from 100 to 80 mm will cause a pressure loss of 3 mbar (0.003 bar).

## Mounting Data

Accurate flow measurement requires a minimum of three pipe diameters of straight pipe upstream and

two pipe diameters of straight pipe downstream from the center of the MagFlux® Flow Sensor.

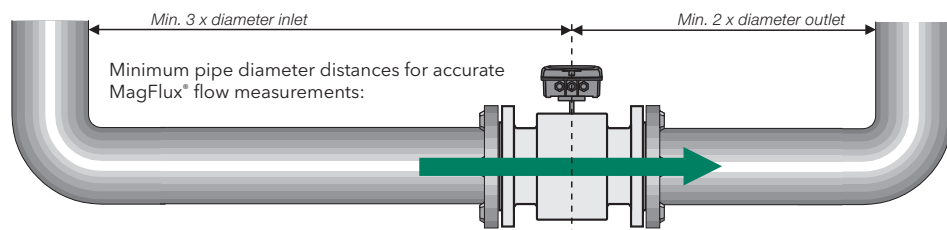

For MagFlux® 8200 Q, a special design allows using short build-in construction but still providing very accurate flow measurements even at one pipe

diameter of straight pipe upstream and one pipe diameter of straight pipe downstream from the center of the MagFlux® Flow Sensor.

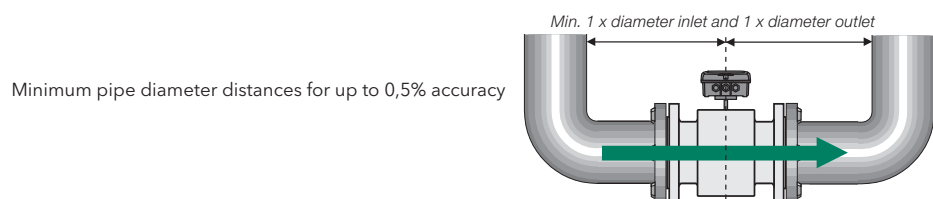

# MagFlux® Electromagnetic Flow Meter



## Online Information

Find the latest updated product information, video tutorials and a lot more on the website.

Use the QR code to find the website. If you use the digital version of the datasheet, just click to go straight to the electromagnetic flow measurement area.

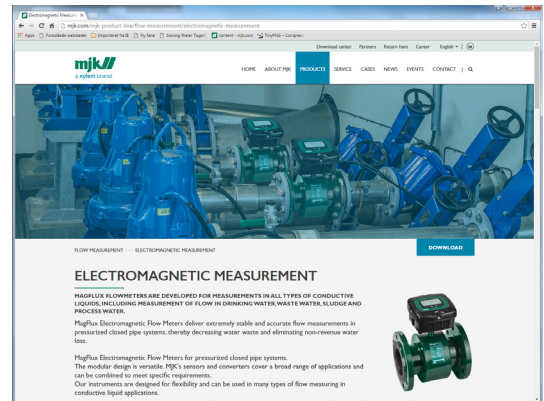

Also try our online MagFlux® sensor configurator: <http://magflux.dk/> which can help you select the correct MagFlux® Flow Meter for you needs.



MJK Automation  
Blokken 9  
DK-3460 Birkerød  
Denmark

Tel +45 45 56 06 56  
[www.mjk.com](http://www.mjk.com)

Connect, Mµ Connect, nConnect, Chatter, MagFlux, Oxix, pHix compact, Shuttle and SuSix are registered trademarks of MJK Automation ApS.

As our products are developed continuously, we reserve the right to make any alterations without prior notice © 2016 Xylem, Inc.

