



Models 30560-2XXX, 30560-3XXX
30560-4XXX, 30560-5XXX

SELF-PRIMING PUMPS

FEATURES

- Pump Type:** 30560-2XXX Pump Head
30560-3XXX Pump Head
30560-4XXX Close Coupled
30560-5XXX Close Coupled
- Body:** 316 Stainless Steel
- Impeller:** Neoprene or EPDM
- Shaft Seal:** Mechanical; Carbon-on-Ceramic or Tungsten Carbide; Nitrile
- Ports:** 1" ACME Threads with Bevel Seat or Clamp Type
- Shaft:** 316 Stainless Steel
- Motor:** 115/230 Vac, Single Phase, 60Hz, 1-1/2 HP, H145 TC Frame, C-Face, 1740 RPM, TEFC, Overload Protected, Capacitor Start.
- Weight:** 30560-2XXX 12.0 lb (5.5 kg) Approx.
30560-3XXX 12.0 lb (5.5 kg) Approx.
30560-4XXX 56.0 lb (25.4 kg) Approx.
30560-5XXX 56.0 lb (25.4 kg) Approx.

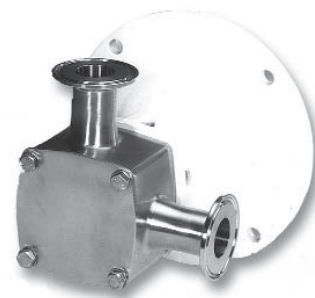

Models 30560-2, 3, 4, 5XXX

VARIATIONS AVAILABLE

Model	Description
30560-2005	Standard Pressure, Neoprene Impeller,
30560-4005	Carbon Seal, ACME Ports
30560-2105	Standard Pressure, Neoprene Impeller,
30560-4105	Tungsten Carbide Seal, ACME Ports
30560-3005	Standard Pressure, Neoprene Impeller,
30560-5005	Carbon Seal, Clamp Ports
30560-3105	Standard Pressure, Neoprene Impeller,
30560-5105	Tungsten Carbide Seal, Clamp Ports

APPLICATIONS

DAIRY: Transfer and processing of raw milk, cream, milk whey, buttermilk, condensed milk.

FOODS: Processing of eggs, sugar liquors, brines, catsup, chocolate, glaze, gelatin, honey, jams, jellies, mayonnaise, molasses, mustard, pickle relish, vinegar, water, yeast slurries, syrups, liquids containing solids in suspension such as chopped tomatoes, nuts, peanut butter.

BEVERAGE: Circulating and transferring alcohols, beers, brewery slop, cider, distillery wort, extracts, flavors, juice, mash, soft drink syrups, wines.

PHARMACEUTICAL: Moving medicines, cosmetics, process chemicals, lotions, preparations, filtering solutions, used as a filling line supply pump.

WARNING Explosion hazard. Do not pump gasoline, solvents, thinners or other flammable liquids. To do so can cause an explosion resulting in injury or death.

WARNING Explosion hazard. Motor can spark. Explosion & death can occur. Do not use where flammable vapors are present.

N.B. 3A option to include Elastomers : EPDM and Neoprene. Ports : Tri-Clamp, IDF, 3A and DIN11851.

OPERATING INSTRUCTIONS

- INSTALLATION** – Pump may be mounted in any position. The rotation of the pump shaft determines the location of the pump's intake and discharge ports. (Refer to dimensional drawing.) Pump is normally assembled at factory for clockwise rotation looking at end cover. If counterclockwise rotation is desired, follow steps 1 and 2 of disassembly and step 9 of assembly instructions to change direction of impeller blade deflection under cam.
- MOTOR SELECTION** – Pump Head is designed to fit a H145 TC Frame NEMA C-Face Motor. Motor should be rated 1-1/2 horsepower at 1750 RPM with a service factor of one. Due to high bearing loads, motor should be ball bearing equipped with the front bearing locked against axial movement. Motor should be capacitor start and foot mounted.
- SPEEDS** – 100 RPM to the maximum shown in the performance curves. For longer pump life, operate at lowest possible speeds. Lower speeds are required for viscous liquids, consult the factory for proper speeds and horsepower requirements.
- SELF-PRIMING** – Primes at low or high speeds. For vertical dry suction lift of 10 feet (neoprene) – 7 feet (EPDM), a minimum of 860 RPM is required. Pump will produce suction lift up to 22 feet when wet.

BE SURE SUCTION LINES ARE AIRTIGHT OR PUMP WILL NOT SELF-PRIME.

- DISCHARGE - When transferring liquids further than 25 feet, use one size larger discharge line than discharge port size.
- RUNNING DRY – Unit depends on liquid pumped for lubrication. DO NOT RUN DRY for more than 30 seconds. Lack of liquid will damage the impeller.
- PUMPAGE COMPATIBILITY – Consult the Chemical Resistance Guide in the JABSCO Industrial Pump Catalog (available upon request from the factory) for proper body materials and impeller compounds. If corrosive fluids are handled, pump life will be prolonged if pump is flushed with a neutralizing solution after each use or after each work day. A Tungsten Carbide Seal variation is available for pumping liquids that contain abrasives or are highly corrosive.
- PRESSURES – Consult Performance Curves for maximum recommended pressures for pump in continuous operation. If pressures exceed those shown, consult the factory.
- TEMPERATURES – The operating temperature limits of the pump depend on the impeller compound. The following ranges apply:
 - Neoprene - 45° to 150° F (7° to 65° C)
 - EPDM - 45° to 185° F (7° to 85° C).
- IMPELLER TORQUE – The torque required to initiate rotation of a new impeller in a dry pump body is:
 - Standard Pressure Impeller (8981-Series):
 - Forward = 4.8 pounds force – feet
 - Reverse = 11.2 pounds force – feet

These values may vary slightly due to impeller compounding, blade set, and body material of construction. Consult factory for more information.

- CLEANING – Before using pump, it should be disassembled and cleaned to remove any dust and dirt resulting from storage or shipping. Wash parts in standard cleaning solutions approved for handling stainless steel. Thoroughly rinse before reassembly. DO NOT USE IODINE BASED SANITIZERS as the iodine attacks the elastomer materials used in the impeller.

N.B. Do not clean with Phosphoric Acid.

All parts have been expertly machined and polished. HANDLE WITH CARE. DO NOT DROP OR MISHANDLE.

- SPARE PARTS – To avoid costly shutdowns, keep a spare JABSCO impeller, seal and O-ring set on hand.

SERVICE INSTRUCTIONS

DISASSEMBLY

- Remove the four end cover screws. Remove end cover and O-ring.
- Remove the four screws, holding the body to the adapter flange. Slide body, complete with impeller and wearplate, from adapter and shaft.
- Remove mechanical seal by inserting two screwdrivers behind seal collar, and gently lever collar and seal assembly forward on shaft. Use extreme care not to mar shaft surface. Remove seal seat and rubber cup from recess in wearplate.

- Remove the four screws holding the adapter to the motor and remove the adapter.
- Stub shaft is held in place with set screws and Loctite* RC/680 retaining compound. Extreme care must be taken not to damage the motor shaft and bearings when removing the stub shaft. Heat shaft joint area to facilitate disassembly of set screws and stub shaft from motor shaft. DO NOT EXCEED 350° F when heating joint area. Once joint area has been heated, remove set screws and slide stub shaft from motor shaft.

ASSEMBLY

- Liberally apply Loctite RC/680 retaining compound to the motor shaft and slide the stub shaft on, positioning the base of the stub shaft 0.37" from the bolt mounting surface of motor and two of the four set screw holes over the keyway in the motor shaft. For clarification refer to figure 1 below. Loctite aids in preventing fretting and subsequent shaft failure. Wipe off excess Loctite. Apply Loctite to the two dog point (flat point) set screws, position in the set screw holes aligned with the keyway of the motor shaft and torque to 55 - 60 in. – lbs. Apply Loctite to the two cup point set screws and torque to 85 - 90 in. – lbs.
- Replace the adapter on the motor and tighten the four mounting screws to 20 ft. – lbs.
- Replace mechanical seal by sliding spacer onto shaft up to locating shoulder, then smear shaft with light lubricating oil. Push on seal gently until it engages with spacer. Fit rubber cup and seal seat into wearplate.
- Insert impeller in pump body, fit O-ring in each end of the pump body.
- Slide wearplate and body assembly over shaft, position wearplate in housing. Fit body to pedestal with screws. Torque screws to 60 in. – lbs. NOTE: A gap should be maintained between bearing housing and body. DO NOT overtighten screws.
- Fit end cover and end cover screws. Torque screws to 60 in. lbs.
- Changing Pump Rotation (looking at end cover):
 - Clockwise Rotation: Insert impeller into pump body with blades bending counterclockwise
 - Counterclockwise Rotation: Insert impeller into pump body with blades bending clockwise.

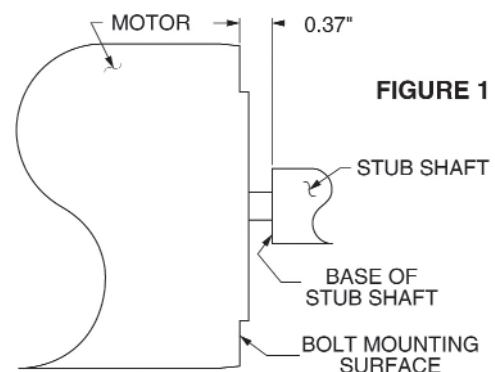

PARTS LIST

Key	Description	Qty. Req.	Model	Model	Model	Model
			30560-2XXX Part No.	30560-3XXX Part No.	30560-4XXX Part No.	30560-5XXX Part No.
1	Adapter	1	18753-0216	18753-0216	18753-0216	18753-0216
2	Body:	1				
	2-A. Clamp Ports			18753-0359		18753-0359
	2-B. ACME Ports		18753-0360		18753-0360	
3	End Cover	1	18753-0361	18753-0361	18753-0361	18753-0361
4	Wearplate	1	18753-0200	18753-0200	18753-0200	18753-0200
5	Shaft	1	18753-0211	18753-0211	18753-0211	18753-0211
6	Impeller:	1				
	Standard Pressure – Neoprene		8981-0005	8981-0005	8981-0005	8981-0005
	Standard Pressure – EPDM		8981-0002	8981-0002	8981-0002	8981-0002
7	Motor: 1-1/2 HP, 115/230 Vac, 1 Ph, 60 Hz, TEFC, H145 TC Frame	1			18753-0339	18753-0339
8	Spacer	1	18753-0227	18753-0227	18753-0227	18753-0227
9	Seal Seat: Ceramic – Nitrile	1	18753-0235	18753-0235	18753-0235	18753-0235
10	Seal Mech.:	1				
	Carbon – Nitrile		18753-0245	18753-0245	18753-0245	18753-0245
	Tungsten Carbide – Nitrile		18753-0364	18753-0364	18753-0364	18753-0364
11	O-Ring: Nitrile	2	18753-0263	18753-0263	18753-0263	18753-0263
12	Screw Kit:	1	18753-0282	18753-0282	18753-0282	18753-0282
	Consists of					
	Screw, Hex Hd. 3/8-16x1"	(4)				
	Screw, Hex Hd. M6x16mm	(4)				
	Screw, Hex Hd. M6x10mm	(4)				
	Set Screw Dog Pt 1/4-20x1/2	(2)				
	Set Screw, Cup Pt. 1/4-20x3/8	(2)				
	Washer, Flat 3/8	(4)				
	Washer, Flat M6	(4)				

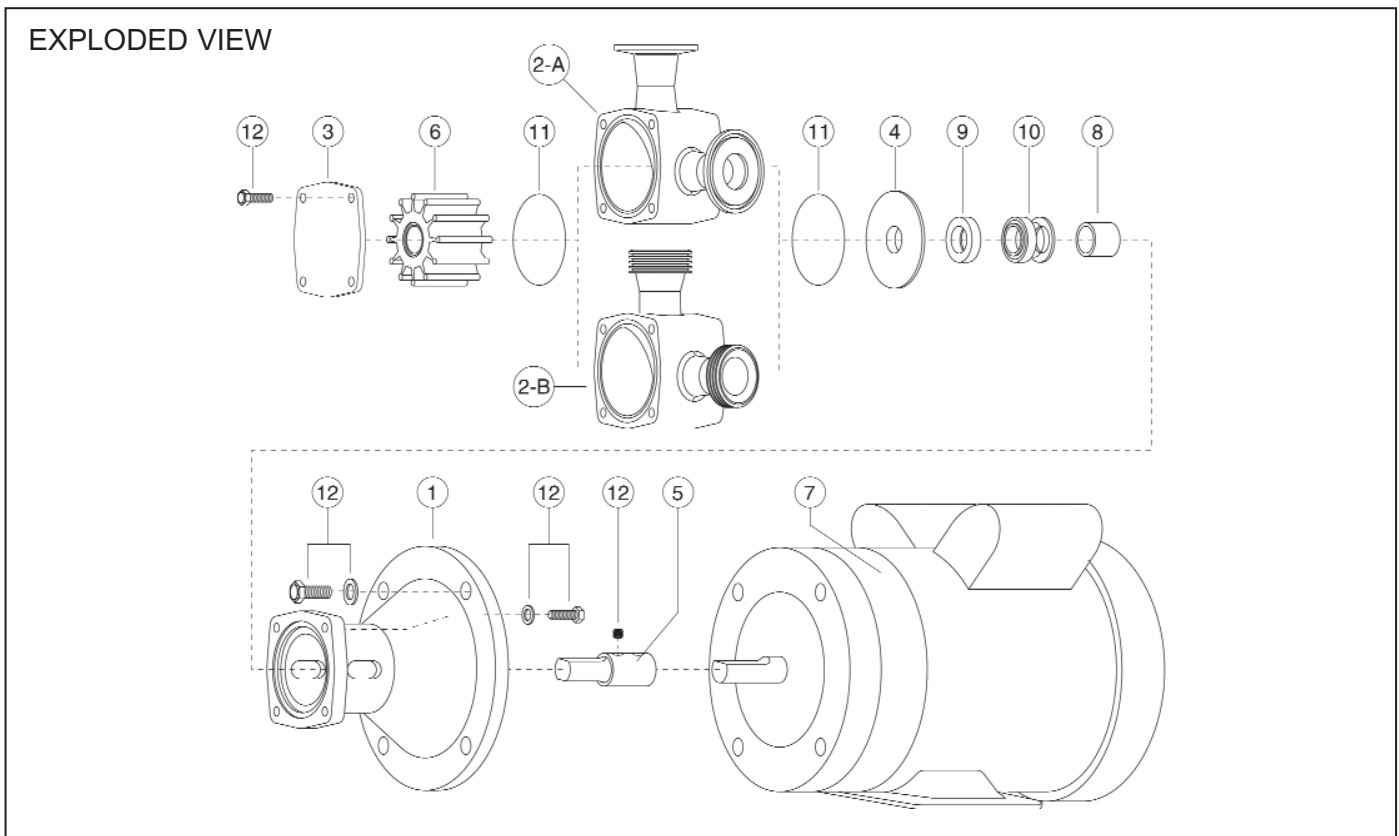

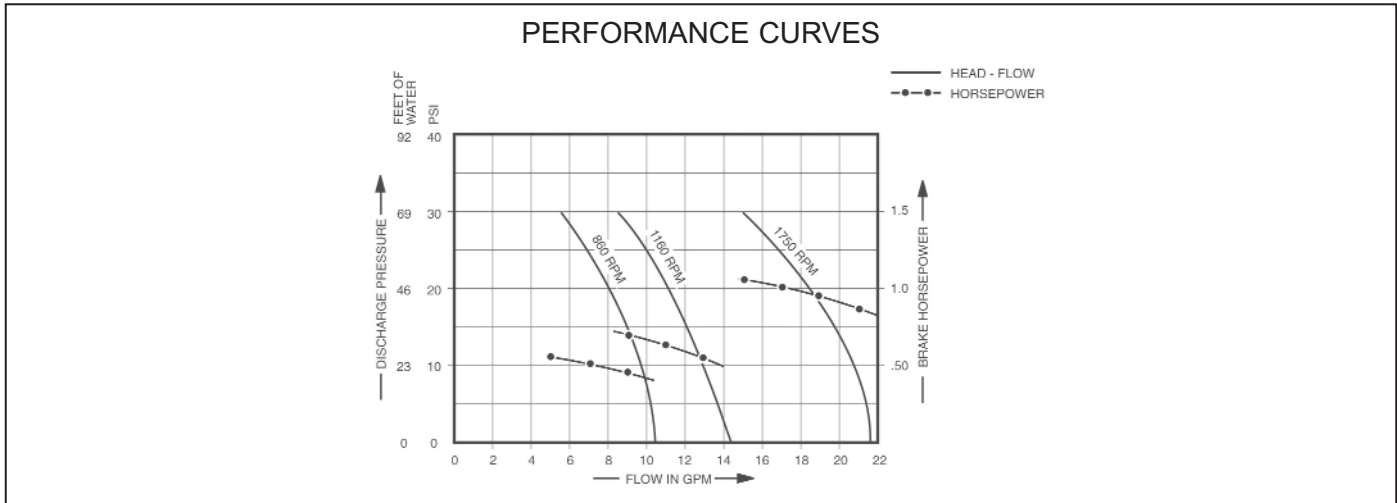
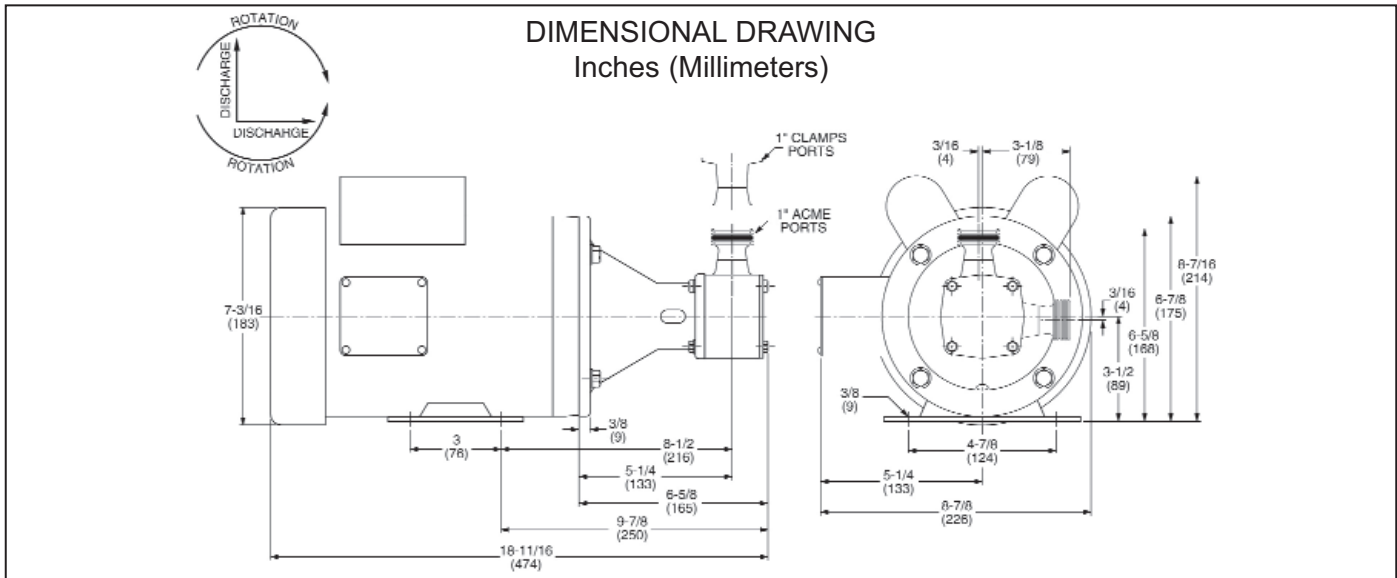

NOTE: Curves show approximate head flow for new pumps with neoprene pumping water.

PUMP SPEED SELECTION ACCORDING TO PRODUCT VISCOSITY

Viscosity S.S.U.	Pump Speed (Max. RPM)	Viscosity S.S.U.	Pump Speed (Max. RPM)	Viscosity S.S.U.	Pump Speed (Max. RPM)	Viscosity S.S.U.	Pump Speed (Max. RPM)
50	1750	700	1680	4,000	1400	15,000*	787
100	1750	800	1645	5,000	1312	20,000*	700
200	1750	900	1610	6,000	1225	30,000*	612
300	1750	1,000	1575	7,000	1138	40,000*	525
400	1750	1,500	1540	8,000	1050	50,000*	437
500	1750	2,000	1505	9,000	962	75,000*	298
600	1715	3,000	1450	10,000	875	100,000*	175

Consult factory for specific performance information. *Use High Pressure Impeller.

Let's Solve Water

Jabsco, 1 Kondelin Road, Cape Ann Industrial Park, Gloucester, MA 01930
Tel: +1 978 281 0440 Fax: +1 978 283 2619 **USA**

Jabsco, Bingley Road, Hoddesdon, Hertfordshire, EN11 0BU
Tel: +44 (0) 1992 450 145 Fax: +44 (0) 1992 467 132 **UK**

NHK Jabsco Co Ltd, 3-21-10, Shin - Yokohama Kohoku-ku, Yokohama 222
Tel: +81 (0) 45 475 8906 Fax: +81 (0) 45 475 8908 **JAPAN**

Jabsco GmbH, Ostraße 78, 22844 Norderstedt
Tel: +49 (0) 40 53 53 73 0 Fax: +49 (0) 49 53 53 73 11 **GERMANY**

Jabsco Italia, s.r.l., Via Iommaseo, 6, 20059 Vimercate, Milano
Tel: +39 039 685 2323 Fax: +39 039 666 307 **ITALY**

Warranty: All products of the company are sold and all services of the company are offered subject to the company's warranty and terms and conditions of sale, copies of which will be furnished upon request. The information provided herein is for guidance only, it does not constitute a guarantee of the performance or specification of any individual product or component.

© 2012 Xylem, Inc. All rights reserved. JABSCO is a registered trademark of Xylem Inc. or one of its subsidiaries.