

### 28220 Series

#### Hygienic Stainless Steel Head Kit Pump

##### Features

- Self primes from dry up to 5.0 metres
- Flows up to 40 litres per minute
- Pressure up to 3.0 bar†
- Handles soft solids - max. 8mm diameter
- Certified to US 3A Standard 02-09
- Clean-In-Place (CIP) or easy strip clean
- Handles viscosities up to 10,000 centiPoise
- Minimal shear to thixotropic fluids
- Fits IEC standard motor B3/B14, frame 80



##### Typical Applications

- Foods, sauces, doughs, preserves, liquid egg, meat pastes
- Dairy products, milk, cream, yoghurt, cheeses
- Cosmetics, toothpaste, shampoos, soaps
- Pharmaceutical creams & lotions
- Wines, beers, soft drinks, fruit juices & syrups
- Ingredients unloading and transfer
- Tank filling and emptying
- Recirculation and mixing
- Portion and container filling
- Brine injection
- Sampling, filtration and more

##### Specifications

**Seal** : Carbon / Ceramic mechanical face seal  
Tungsten Carbide / Ceramic hard faced seal  
Flushed options for crystallising fluids

**Seal Elastomer** : Food grade Nitrile

**Pump Head** : Stainless steel 316, machined interior and electropolished exterior finish

**End Cover** : Stainless steel 316 grade

**Shaft** : Stainless steel 316 grade shaft extension

**Bearings** : Uses motor bearings

**Motor Adaptor** : Epoxy coated cast iron

Ports :			
1"	Tri-Clamp	28220-1xxx	
25mm	IDF/ISS	28220-3xxx	
1"	RJT to BS1864	28220-4xxx	
1"	3A Bevel Seat	28220-5xxx	
25mm	DIN 11851	28220-6xxx	
25mm	SMS 1145	28220-7xxx	

##### Model Range

**Weight** : 2.5kg

Pressure options	Standard - Max 2.5 bar		High - Max 3.0 bar†	
	3A Neoprene	E.P.D.M.	3A Neoprene	E.P.D.M.
Elastomer option	3A Neoprene	E.P.D.M.	3A Neoprene	E.P.D.M.
Temperature range	4°C to 65°C	0°C to 120°C	4°C to 65°C	0°C to 120°C
<b>Mechanical Seal Options</b>				
Carbon/Ceramic	28220-x105	28220-x102	28220-x125	28220-x122
Tungsten Carbide/Ceramic hard faced	28220-x205		28220-x225	
<b>Flushed Mechanical Seal</b>				
Tungsten Carbide/Ceramic hard faced	28220-x705		28220-x725	
Carbon/Ceramic	28220-x905		28220-x925	

For models not listed above, consult distributor or factory, 'x' Substitute port code from table above

Note : it is not recommended to start the pump at extremes of the temperature range, impeller damage may occur

For Installation, Operating, Maintenance and Safety Instructions refer to form 43001-0543

**⚠ WARNING** Explosion hazard. Do not pump gasoline, solvents, thinners or other flammable liquids. To do so can cause an explosion resulting in injury or death.



† Pressures over 2.5 bar may reduce motor shaft life

Fits IEC motor with foot & face to IEC B3/B14 frame size 80

### 28220 Series

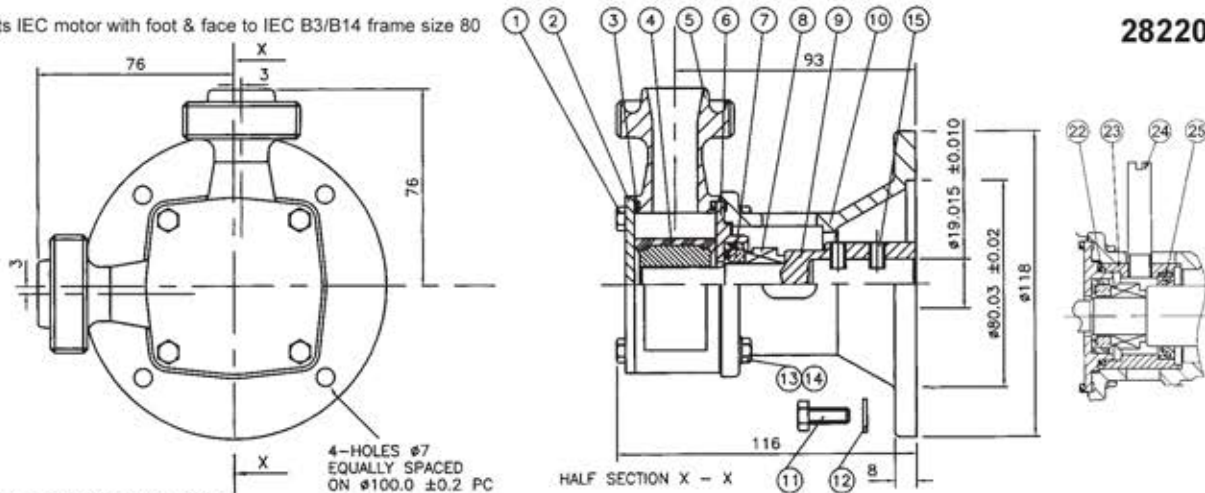

Dimensions in mm

For performance data refer to the 040 size flexible impeller pump performance curves

### Parts List

Key	Description	Qty	Part Number
1	Screw	4	X3001-147F
2	Endcover	1	28205-0020
3	O'Ring *	2	See right
4	Impeller*	1	See right
5	Body	1	See right
6	Wearplate	1	28236-0000
7 / 8	Seal Assembly *	1	See right
9	Shaft Extension	1	28227-0001
10	Motor Adaptor	1	28223-0000
11	Screw	4	X3001-180F
12	Washer	4	X3080-091K
13	Screw	4	X3001-153F
14	Washer	4	X3080-081F
15	Set Screw	2	X3009-176A
22	O-Ring	1	X4020-237A
23	Seal Housing	1	28212-0000
24	Tube	2	21844
25	Seal	1	SP2701-0913

Parts marked \* Contained in service kit

### Spare Parts & Service Kits

Pressure Rating		Standard	High	
3	O-Ring	Nitrile X4020-259A	X4020-259A	
4	Impeller	3A Neoprene	7614-0005B	8980-0005B
		E.P.D.M.	7614-0002B	8980-0002B
		Tri-Clamp	28204-1000	28204-1000
5	Body	IDF/ISS	28204-3000	28204-3000
		RJT	28204-4000	28204-4000
		Bevel Seat	28204-5000	28204-5000
		DIN	28204-6000	28204-6000
		SMS	28204-7000	28204-7000
7 / 8	Seals	Std Mech.	28231-0103B	28231-0103B
		Hard Faced	28231-0203B	28231-0203B
Service Kit		3A Neoprene	SK376-0105	SK376-0125
		E.P.D.M.		

Models with Neoprene and E.P.D.M. impellers use Nitrile elastomers on seals and O-rings.  
 High Temperature impeller part no. 23470-0065B available separately.  
 NOTE:- Service Kits contain standard mechanical seals. For hard faced seals, order parts separately.

### Other Available Options

Pedestal pumps, for higher pressure capability.

## Jabsco

### USA

**Jabsco**  
 1485 Dale Way  
 Costa Mesa  
 CA 92628-2158

Tel : +1 714 545 8251  
 Fax : +1 714 957 0609

### UK

**Jabsco**  
 Bingley Road  
 Hoddesdon  
 Hertfordshire, EN11 0BU

Tel : +44 (0) 1992 450 145  
 Fax : +44 (0) 1992 467 132

### GERMANY

**Jabsco GmbH**  
 Oststraße 28  
 22844 Norderstedt

Tel : +49 (0) 40 53 53 73 0  
 Fax : +49 (0) 40 53 53 73 11