



Model 2760-Series

SELF-PRIMING PUMPS

FEATURES

- Body:** Bronze
- Impeller:** Neoprene, Nitrile
- Shaft:** Stainless Steel
- Wear Plate:** Replaceable
- Shaft Seal:** Lip Type
- Bearings:** Sealed Ball Bearing
- Ports:** 1/4" NPT Internal
- Weight:** 1-1/2 lb (0.7 kg) approx.

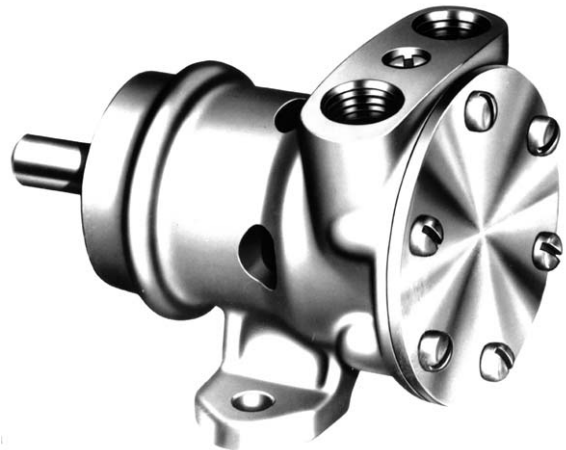

Model 2760-Series

VARIATIONS AVAILABLE

- 2760-0001** Neoprene Impeller
- 2760-0003** Nitrile Impeller

APPLICATIONS

MARINE: Engine cooling, Pumping bilges, Washdowns, Circulating water in bait tanks.

INDUSTRIAL: Circulating and transferring, Velocity-mixing, Pumping machine tool coolants, Return spill, Sump drainage, Chemicals, Pharmaceuticals, Soap, Liquors, Ink, Dyes, Alcohol, Various acids, Tanning liquors, Glycerine, Brine.

⚠ WARNING Injury hazard. Exposed pulleys and belts can cause injury. Install shield around pulleys and belts. Stay clear while machinery is operating.



OPERATING INSTRUCTIONS

- 1. INSTALLATION** - Pump may be mounted in any position. Intake and discharge ports are determined by the direction of shaft rotation (refer to Dimensional Drawing). Before installing, turn the pump shaft in the direction of the operating rotation,
- 2. DRIVE** - Belt or Direct with flexible coupling.
BELT DRIVE - Overtight belt load will reduce bearing life.
DIRECT DRIVE - Clearance should be left between drive shaft and pump shaft when installing coupling. Always mount and align pump and drive shaft before tightening the coupling set screw.
NOTICE: If drive pulley or coupling must be pressed on shaft, remove end cover and impeller and support shaft from impeller end during press operation. Do not hammer a pulley or coupling on shaft. Failure to follow above instructions can damage the pump.

- 3. SPEEDS** - 100 RPM to the maximum shown in the performance table. Consult the factory for operation at speeds above those shown. For longer pump life, operate at lowest possible speeds.
- 4. SELF-PRIMING** - Primes at low or high speeds. For vertical dry suction lift of 10 feet, a minimum of 800 RPM is required. Pump will produce suction lift up to 22 feet when wetted. **BE SURE SUCTION LINES ARE AIRTIGHT OR PUMP WILL NOT SELF-PRIME.**
- 5. RUNNING DRY** - Unit depends on liquid pumped for lubrication. **⚠ CAUTION** Do not run dry for more than 30 seconds. Lack of liquid will damage the impeller.
- 6. NOTICE** - If pumping light fraction petroleum derivatives, solvents, thinners, highly concentrated or organic acids, consult Jabsco Chemical Resistance Table (which is available upon request from ITT Jabsco) for proper body materials and impeller compounds. If corrosives fluids are handled, pump life will be prolonged if pump is flushed with water after each use or after each work day.
- 7. PRESSURES** - Consult Head Capacity Table for recommended maximum for continuous operation. If pressures exceed those shown, consult the factory.
- 8. TEMPERATURES** - Neoprene 45°–180°F (7°–82°C), Nitrile 50°–118°F (10°–82°C).
- 9. FREEZING WEATHER** - Drain unit by loosening end cover.
- 10. GASKET** - Use a standard pump part. Thicker gasket will reduce priming ability. A thinner gasket will cause the impeller to bind. Standard gasket is 0.010" thick.
- 11. SPARE PARTS** - To avoid costly shut downs, keep a JABSCO Service Kit on hand.

TOTAL HEAD		500 RPM		1160 RPM		1750 RPM		2100 RPM		2450 RPM		3000 RPM		3600 RPM	
P.S.I. (kg/sq cm)	Ft. of Water (metre)	G.P.M. (LPM)	H.P.	G.P.M. (LPM)	H.P.	G.P.M. (LPM)	H.P.	G.P.M. (LPM)	H.P.	G.P.M. (LPM)	H.P.	G.P.M. (LPM)	H.P.	G.P.M. (LPM)	H.P.
4.3 (0.3)	10 (3)	1.2 (4.5)	1/12	2.6 (9.8)	1/6	3.9 (14.8)	1/6	4.6 (17.7)	1/4	5.2 (19.6)	1/4	6.1 (23)	1/4	6.9 (26.1)	1/3
8.7 (0.6)	20 (6)	1.1 (4)	1/12	2.4 (10.5)	1/6	3.6 (13.6)	1/6	4.3 (16.2)	1/4	4.8 (18)	1/4	5.6 (21.1)	1/4	6.5 (24.9)	1/3
13.0 (0.9)	30 (9)	0.8 (3)	1/12	2.1 (7.8)	1/6	3.1 (11.7)	1/6	3.8 (14.4)	1/4	4.2 (15.9)	1/4	5.1 (19.2)	1/3	5.9 (22.3)	1/3
17.3 (1.2)	40 (12)	-	-	1.7 (6.4)	1/6	2.6 (9.8)	1/6	3.2 (12.1)	1/4	3.7 (13.9)	1/4	4.5 (16.9)	1/3	5.2 (19.6)	1/3
21.6 (1.5)	50 (15)	-	-	-	-	-	-	2.5 (9.3)	1/4	3.0 (11.3)	1/4	3.8 (14.4)	1/3	4.5 (16.9)	1/3

NOTE: Progressively longer life may be expected as operating pressures and speeds are reduced. Factory Application Engineering assistance suggested for operation in light shaded area and recommended for heavy shaded area. Capacitor type motor recommended. Table shows approximate Head-Row for new pump in U.S. gallons per minute.

SERVICE INSTRUCTIONS

Impeller Replacement: Remove end cover screws, end cover and gasket. Grasp impeller hub with water pump pliers and pull straight out of body. Lubricate impeller bore. Once started, line up impeller screw with slot in shaft and push impeller straight into body. Lubricate face of impeller, install gasket, end cover, and secure with end cover screws.

Major Repair: Follow steps outlined above to remove impeller. Remove outer bearing seal, remove bearing to body retaining ring. Pressing on impeller end of shaft, remove shaft and bearing assembly. Remove inner bearing seal. Remove slinger from inside bearing housing. Remove cam and wearplate from impeller bore. Clean sealant off of cam top.

Remove seal and O-ring. Use care not to scratch or mar O-ring groove or seal bore. Supporting bearing inner race, press shaft through bearing.

ASSEMBLY

Press bearing on shaft. Use care to support inner race of bearing. Drop slinger into bearing bore. Lubricate inner bearing seal with water pump grease or equivalent, and press into body bearing seal bore with lip facing away from bearing. Insert slotted end of shaft into bearing bore, aligning slinger on shaft and pressing on bearing outer race, press bearing and shaft assembly into bore. Install bearing to body retaining ring in body groove with flat side toward bearing.

Lubricate outer bearing seal with grease and press into bore until flush with body. Install seal in place, using care to protect lip from burrs or protrusions on shaft. Lip of seal must face impeller bore. Place O-ring in recess between lip seal and body. Install wearplate and cam assembly. Apply a thin coat of sealant to top of cam and cam screw threads, tighten cam screw making sure cam is flush with end cover surface. Replace impeller, gasket and end cover as outlined above.

EXPLODED VIEW

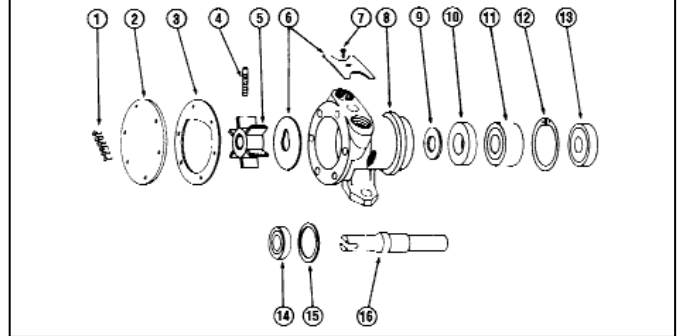

PARTS LIST

Key	Description	Qty.	Part Number
1	Screw End Cover	6	91002-0010
2	End Cover	1	12066-0000
3	Gasket**	1	1189-0000
4	Impeller Screw**	1	91009-0050
5	Impeller** - Neoprene	1	4528-0001
	Nitrile		4528-0003
6	Wearplate & Cam Assembly	1	4271-0000
7	Cam Screw	1	91002-0030
8	Body	1	2767-0000
9	Slinger	1	6342-0000
10	Inner Bearing Seal	1	1041-0000
11	Ball Bearing	1	92600-0080
12	Retaining Ring (Brg. to Body)	1	18717-0000
13	Outer Bearing Seal	1	1039-0000
14	Seal**	1	92700-0110
15	O-Ring**	1	92000-0560
16	Shaft	1	1053-0000
	Service Kit - Neoprene		90023-0001
	Nitrile		90023-0003

**Parts supplied in Service Kit.

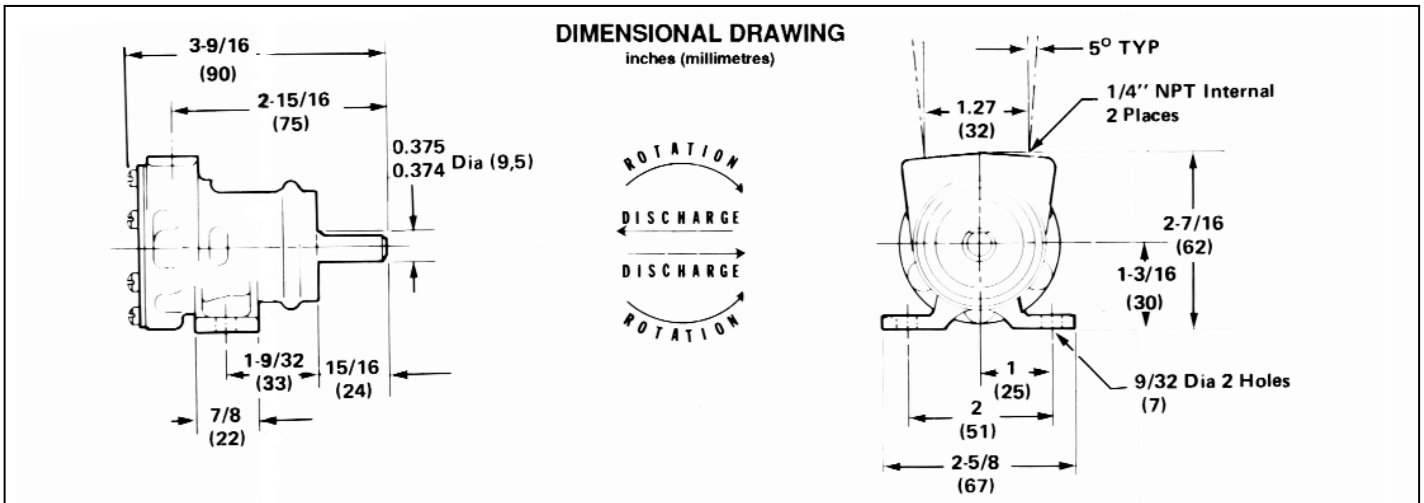

xylem
Let's Solve Water

www.xylem.com

UK
Xylem
Bingley Road, Hoddesdon
Hertfordshire EN11 0BU
Tel: +44 (0) 1992 450145
Fax: +44 (0) 1992 467132

USA
Xylem
100 Cummings Center Drive
Suite 535-N, Beverly, MA 01915
Tel: +1 978 281-0440
Fax: +1 978 283-2619

ITALY
Xylem
Via Tommaseo, 6
20059 Vimercate, Milano
Tel: +39 039 685 2323
Fax: +39 039 666 307

GERMANY
Xylem
Oststrasse 28
22844 Norderstedt
Tel: +49-40-53 53 73-0
Fax: +49-40-53 53 73-11

JAPAN
Xylem
3-21-10, Shin-Yokohama
Kohoku-Ku, Yokohama, 222-0033
Tel: +81-045-475-8906
Fax: +81-045-477-1162

Warranty: All products of the company are sold, and all services of the company are offered subject to the company's warranty and terms of sale, copies of which will be furnished upon request. Details correct at time of printing. We reserve the right to change specifications without prior notice.

© Copyright 2013 Xylem Inc. Jabsco is a trademark of Xylem Inc. or one of its subsidiaries.

43000-0224 Rev: B