



AQUAVAR SOLO²™

CONSTANT PRESSURE CONTROLLERS FOR: 1Ø - 3-WIRE MOTORS,
1Ø - 2-WIRE GOULDS WATER TECHNOLOGY MOTORS, 3Ø MOTORS



FEATURES

LED display clearly indicates actual system pressure, output frequency, current draw and error log.

Dual system set points for advanced system application.

Programmable output relay can be configured to run optional accessories such as a chlorinator, or link to a home monitoring system.

NEMA 3R Enclosure: Rainproof, outdoor/indoor rated enclosure.

Current Limit Selector Switch: Rotary switch to set current limit to match motor Service Factor Amps (SFA).

Dry Well Sensitivity Switch: Choice of low or high sensitivity.

Pressure Drop: Choose a 5 or 20 PSI pressure drop for restarts.

Low Pressure Cut-Off: Set on or off depending on application.

Constant Pressure: Provides consistent pressure even as flow requirements vary.

Controller acts as a pump protection and troubleshooting device. Flashing lights indicate system faults.

Standard pressure sensor cable is 10' long. Optional lengths of 25', 50', 100', 150' and 200' are available.

Integrated output motor filter protects the motor from voltage spikes and limits electrical interference with devices such as portable telephones, radios, televisions and garage door openers.

Cooling Fan: Allows operation in ambient temperatures up to 122°F.

AGENCY LISTINGS



Tested to UL 508C and CSA 22.2 0-M91, 14-95 and 0.4-M1982 Standards By Canadian Standards Association File #LR38549



Drinking Water System Components - Health Effects & Optional Annex G - Class 6861 18 - Mechanical Devices - NSF/ANSI 61 - Certified to NSF/ANSI 61 Sect. 8 (including optional Annex G)

USER INTERFACE BOARD

1AS Controllers

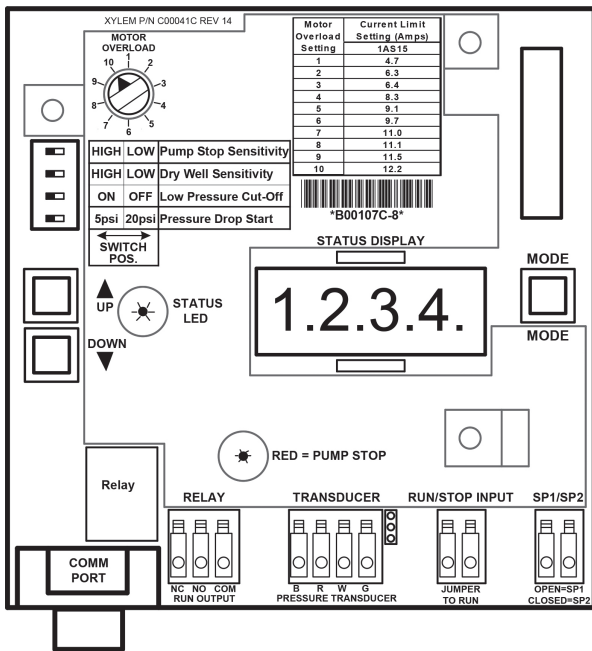

3AS Controllers

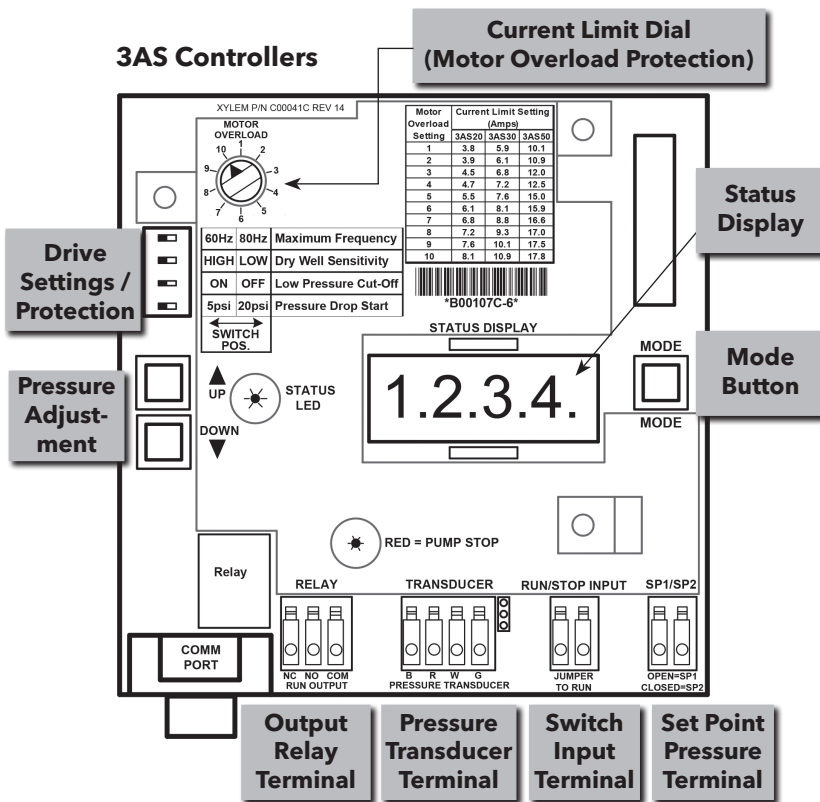

SPECIFICATIONS - 3Ø MODELS / 1Ø INPUT AND 3Ø OUTPUT

Controller Temperature Range:

- Minimum Ambient Temperature: -4°F (-20°C)
- Maximum Ambient Temperature: +122°F (+50°C)

Input Voltage: single-phase, 230 Volt, two (2) wire grounded system.

Output Voltage: variable frequency, variable voltage, three-phase power to the motor.

Speed Selector Switch: Selects Output Frequency of either -

- 30 - 60 Hz - Use matched HP Water End and Motor
- 30 - 80 Hz - Use mis-matched Water End and Motor

Enclosure Dimensions:

- Height: 18.6"
- Width: 9.9"
- Depth: 5.3"

Packaged Dimensions:

- Height: 21"
- Width: 13"
- Depth: 8"

Motor Compatibility with 3AS_ _ Models

HP	Three Phase	
	Goolds & Pentek XE	Franklin & Grundfos
¾	Yes	Yes
1	Yes	Yes
1½	Yes	Yes
2	Yes	Yes
3	Yes	Yes
5	Yes	①

① Amps may be higher than controller overload range - use of these motors will current limit and provide reduced performance.

3AS20 SPECIFICATIONS

- HP Range: ¾ to 2
- Unit Weight: 19 lbs.
- Packaged Weight: 23 lbs.
- Pressure Set point adjustable from 20 - 85 psi using the standard 100 psi sensor. ①

3AS30 SPECIFICATIONS

- HP Range: 1½ to 3
- Unit Weight: 20 lbs.
- Packaged Weight: 24 lbs.
- Pressure Set point adjustable from 20 - 85 psi using the standard 100 psi sensor. ①

3AS50 SPECIFICATIONS

- HP Range: 3 to 5
- Unit Weight: 25 lbs.
- Packaged Weight: 29 lbs.
- Pressure Set point adjustable from 20 - 100 psi using the standard 200 psi sensor. ①

① Higher pressures are available using a higher pressure sensor. See page 4.

DIMENSIONS (inches) - ALL MODELS

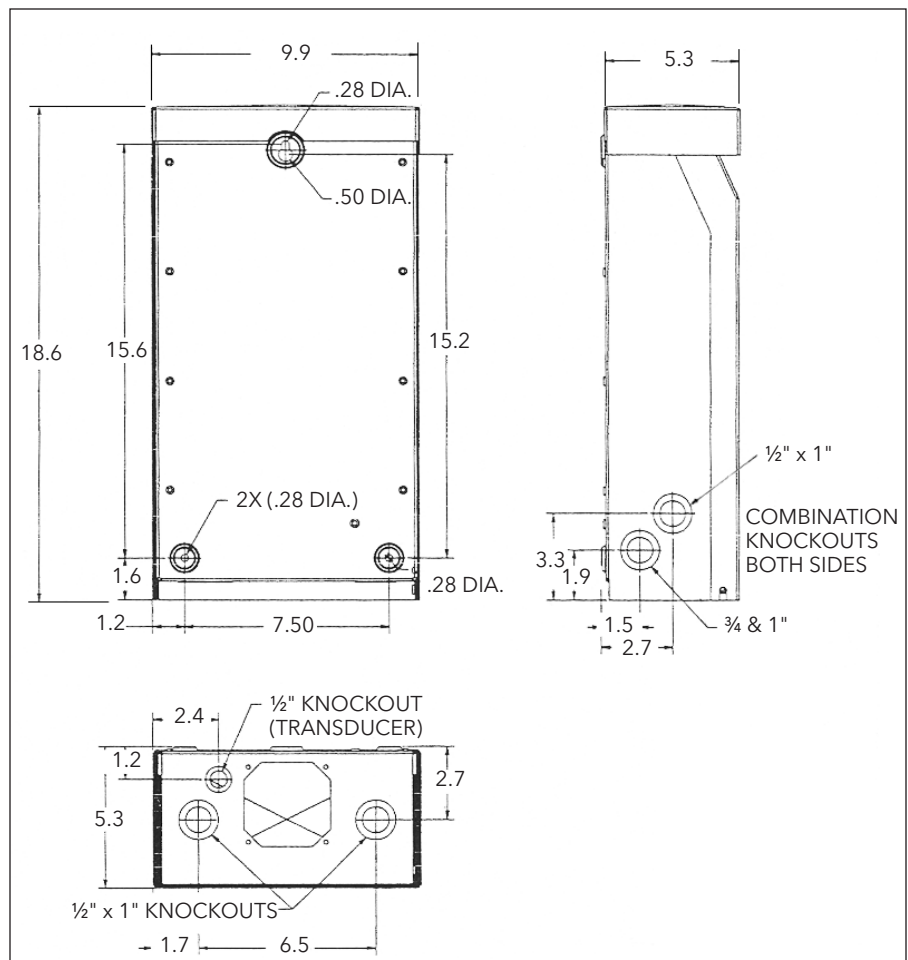

SPECIFICATIONS - 1AS15 - 1Ø MODEL - 1Ø INPUT AND 1Ø OUTPUT

Controller Temperature Range:

- Minimum Ambient Temperature: 14°F (-10°C)
- Maximum Ambient Temperature: 122°F (50°C)

Input Voltage: single-phase, 230 Volt, two (2) wire grounded system.

Output Voltage: 1Ø, variable voltage, variable frequency, single phase power to the 2-wire or 3-wire motor

Speed/Frequency: 30-60 only

Enclosure Dimensions:

- Height: 18.6"
- Width: 9.9"
- Depth: 5.3"

Packaged Dimensions:

- Height: 21"
- Width: 13"
- Depth: 8"

1AS15 SPECIFICATIONS

- Unit Weight: 19 lbs.
- Packaged Weight: 23 lbs.
- Pressure Set point adjustable from 20 - 85 psi using the standard 100 psi transducer.
- HP Range:

Motor Compatibility with AQUAVAR SOLO 1AS15

HP	Single Phase 2-Wire		Single Phase 3-Wire	
	Goulds & Pentek XE	Franklin, Grundfos and Flint & Walling	Goulds & Pentek XE	Franklin, Grundfos and Flint & Walling
½	Yes	Yes	Yes	Yes
¾	Yes	Yes	Yes	Yes
1	Yes	Yes	Yes	Yes
1½	Yes	Yes	Yes	Yes
2	No	No	Yes	①

① Amps are higher than controller overload range - use of these motors will current limit and provide reduced performance.

TANK SIZING

Diaphragm Tank Sizing and Pre-Set Pressure Recommendations:

Diaphragm type (captive air) tanks are required on these systems.

Table 1: Tank Sizing Selection

Maximum Pump GPM	Recommended Tanks	
	Total Volume	Order Number
10	1.9	V6P
24	4.9	V15P
36	7.3	V25P
70	13.9	V45
100	19.9	V60

Use Total Tank Volume, not drawdown volume, to select the proper tank size. The total tank volume should be approximately 20% of the pump's maximum flow. For example, when using a 10 gpm pump the system requires a minimum 2 gallon (total volume) tank.

The tank sizing recommendations are field proven to prevent objectionable pressure drops on start-up and provide smooth operation for the majority of variable speed pump systems.

When using the default, 5 PSI pressure drop, setting: Set the tank pressure, while tank is empty of water, to 20 psi below the desired system pressure setting. Ex. for a 50 psi system pressure, charge the tank to 30 psi.

See IOM for other settings or if using a large tank.

Table 2: Controller, Breaker, Generator Sizing

Motor		Controller Model ^②				Circuit Breaker ^③	Generator ^④ (VA)	<p>① Supply voltage must be 196 VAC - 265 VAC.</p> <p>② Shaded areas indicate which controller models can be used with which motors. Lighter shading indicates combinations where controller will limit peak performance to 85% of catalog value for pump/motor.</p> <p>③ Circuit Breaker or Dual Element Time Delay Fuse Size (Amps) protecting branch circuit supplying controller.</p> <p>④ Minimum size of single phase 240 V generator required.</p>
HP	Voltage ^①	1AS15	3AS20	3AS30	3AS50			
½	230					15	2200	
	200							
¾	230						2900	
	200							
1	230						3500	
	200							
1½	230					20	4400	
	200							
2	230					30	6100	
	200							
3	230					40	8100	
	200							
5	230					50	13300	
	200							

Table 3: Service Factor Amps All Motors

HP	230 Volt						200 Volt				
	1Ø 2-Wire			1Ø 3-Wire			3Ø			3Ø	
	Goolds	Franklin	Grundfos	Goolds	Franklin	Grundfos	Goolds	Franklin	Grundfos	Goolds	Franklin
½	4.8	6	6	5	6	6	N/A	N/A	N/A	N/A	N/A
¾	6.4	8	8.4	6.1	8	8.4	4	3.8	N/A	4.7	4.4
1	8.2	9.8	9.8	7.4	9.8	9.8	4.9	4.7	N/A	5.7	5.4
1½	10.5	13.1*	13.1*	11	11.5	11.6	6.6	5.9	7.3	7.6	6.8
2	N/A	N/A	N/A	12.2	13.2*	13.2*	8	8.1	8.7	9.3	9.3
3	N/A	N/A	N/A	N/A	N/A	N/A	10.1	10.9	12.2	12	12.5
5	N/A	N/A	N/A	N/A	N/A	N/A	17.5	17.8	19.8*	20.2*	20.5*

* Amps are higher than controller overload range - use of these motors will current limit and provide reduced performance.

PRESSURE RANGES FOR ALL AVAILABLE TRANSDUCERS

Transducer	Minimum PSI	Maximum PSI
100 PSI ^①	20	85
200 PSI ^②	20	170
300 PSI	20	255

① Standard on 1AS15/3AS20, 3AS30 ② Standard on 3AS50

Warning! Exploding tank can injure or kill, some combinations of Transducer and Controller allow system pressure adjustment to exceed the maximum working pressure of the tank and piping.

Ensure system pressure is set below the maximum working pressure of the tank and system piping.

Protect tank and piping against overpressure, install a properly sized pressure relief valve (PRV) able to pass full pump flow at the maximum working pressure of the tank. In finished basements or where PRV blow-off can cause property damage, pipe the PRV to a suitable drain.

Table 4: Wire Sizing
Maximum Cable Lengths in Feet to Limit Voltage Drop to 5% for 230 V Systems ①

1A515 Controller to Motor - Controllers with 2-Wire 1Ø Motors

Motor Lead Lengths - Goulds water technology 2-Wire Motors - Based on Service Factor Amps, 30° C Ambient and 5% Voltage Drop														
Motor Rating				60° C & 75° C Insulation - AWG Copper Wire Size										
Volts	HP	kW	SFA	14	12	10	8	6	4	2	1/0	2/0	3/0	4/0
230	½	0.37	4.8	457	726	1158	1835	2855	4551	7225	11489	14803	18688	23544
	¾	0.55	6.4	342	545	869	1376	2141	3413	5419	8617	10871	13724	17290
	1	0.75	8.2	267	425	678	1074	1671	2664	3349	6725	8485	10711	12160
	1½	1.1	10.5	209	332	530	839	1305	2080	3303	4161	6626	8365	10060

1A515 Controller to Motor - Controllers with 3-Wire 1Ø Motors

Motor Lead Lengths - Goulds water technology 3-Wire Motors (CSIR) - Based on Service Factor Amps, 30° C Ambient and 5% Voltage Drop														
Motor Rating				60° C & 75° C Insulation - AWG Copper Wire Size										
Volts	HP	kW	SFA	14	12	10	8	6	4	2	1/0	2/0	3/0	4/0
230	½	0.37	5	438	697	1112	1761	2740	4369	6936	11029	11044	13942	17564
	¾	0.55	6.1	359	571	912	1444	2246	3581	5685	9040	11406	10582	13332
	1	0.75	7.4	296	471	751	1190	1852	2952	4686	7452	9402	9055	11408
	1½	1.1	11.1	199	317	505	801	1246	1986	3153	5013	6325	7913	9969
	2	1.5	12.2	180	286	456	722	1123	1790	2843	4520	5703	7199	9070

All Models - Service Entrance to Controller

Controller Input	Motor HP	Copper Wire Size 75°C Insulation Exposed to a Maximum of 50°C (122°F) Ambient Temperature ②																	
		14	12	10	8	6	4	3	2	1	1/0	2/0	3/0	4/0	250	300	350	400	500
230V 1 PH	¾	279	445	706	1020	1608	2552	3186	4019	5065	6383	8055							
	1	226	360	571	824	1300	2064	2576	3250	4095	5161	6513	8201						
	1½	*	286	455	657	1036	1644	2052	2589	3262	4111	5188	6533	8236	9710				
	2	*	*	331	478	754	1197	1495	1886	2376	2995	3779	4759	5999	7073	8455	9852		
	3	*	*	246	355	561	890	1111	1401	1766	2225	2808	3536	4458	5256	6283	7321	8343	
	5	*	*	*	218	343	545	680	858	1081	1363	1720	2165	2730	3219	3847	4483	5109	6348

3A520, 30, 50 Controller to Motor - Controllers with 3Ø Motors

Controller Output	Motor HP	Copper Wire Size 75°C Insulation Exposed to a Maximum of 50°C (122°F) Ambient Temperature ②																	
		14	12	10	8	6	4	3	2	1	1/0	2/0	3/0	4/0	250	300	350	400	500
230V 3 PH	0.75	633	1006	1605	2542	3956	6306	7927	10011										
	1	516	821	1310	2075	3229	5148	6471	8172										
	1.5	383	610	973	1541	2397	3822	4804	6067	7643	9648								
	2	316	503	803	1271	1978	3153	3964	5006	6306	7960	10042							
	3	251	399	636	1007	1567	2497	3140	3965	4995	6305	7954	10042	12651					
	5	145	230	367	581	904	1441	1812	2288	2883	3639	4591	5795	7301	7964	9520			

① Reduce lengths by 13% for 200 V systems. * Wire does not meet the N.E.C. ampacity requirement.

② Lengths in bold require 90° C wire. ■ Shading indicates 40° C maximum ambient.

The lengths in each of the Wire Sizing tables represent 100% of the allowable voltage drop when motor is running at full load. When sizing wire, the voltage drop of each wire segment must be included. The total must not exceed 100% of the allowable drop. Take for example a 1.5 HP motor with a distance from Service Entrance to Controller of 100' and 500' between the Controller and Motor.

- Service Entrance to Controller = 100' of 10 AWG (100/455) = 22 % (455' is from the S.E. to Controller chart)
 - Controller to Motor = 500' of 12 AWG (500/709) = 71 % (709' is from the Controller to Motor chart)
- Total Drop (must be ≤ 100%) = 93 %

If the distance from the Controller to Motor was 600' (600/709) = 85% + 22% = 107%, we would need to use #10 wire for that segment, ex. 600/1126 = 53% + 22% (for 100' of #10) = 75% which is acceptable. It is also acceptable to use different wire sizes for the Buried and Well sections of wire.

3Ø, 4" MOTORS - ELECTRICAL DATA, 60 HERTZ 3450 RPM

Goulds water technology #	Red Jacket #	HP	kW	Volts	SF	Full Load		Service Factor		Locked Rotor Amps	Line - Line Resistance
						Amps	Watts	Amps	Watts		
M07430	75C323	0.75	0.55	200	1.5	3.8	812	4.5	1140	32	2.6-3.0
M10430	100C323	1	0.75		1.4	4.6	1150	5.5	1500	29	3.4-3.9
M15430	150C323	1.5	1.1		1.3	6.3	1560	7.2	1950	40	1.9-2.5
M20430	200C323	2	1.5		1.25	7.5	2015	8.8	2490	51	1.4-2.0
M30430	300C323	3	2.2		1.15	10.9	2890	12.0	3290	71	0.9-1.3
M50430	500C323	5	3.7		1.15	18.3	4850	20.2	5515	113	0.4-0.8
M75430	750C323	7.5	5.5		1.15	27.0	7600	30.0	8800	165	0.5-0.6
M07432	75C313	0.75	0.55	230	1.5	3.3	850	3.9	1185	27	3.3-4.3
M10432	100C313	1	0.75		1.4	4.0	1090	4.7	1450	26.1	4.1-5.1
M15432	150C313	1.5	1.1		1.3	5.2	1490	6.1	1930	32.4	2.8-3.4
M20432	200C313	2	1.5		1.25	6.5	1990	7.6	2450	44	1.8-2.4
M30432	300C313	3	2.2		1.15	9.2	2880	10.1	3280	58.9	1.3-1.7
M50432	500C313	5	3.7		1.15	15.7	4925	17.5	4925	93	.83-1.25
M75432	750C313	7.5	5.5		1.15	24	7480	26.4	8570	140	.55-.85

1Ø, 4" MOTORS - ELECTRICAL DATA, 60 HERTZ 3450 RPM

Type	Motor Order Number		HP	KW	Volts	SF	Full Load		Service Factor		Locked Rotor Amps	Winding Resistance	
	Goulds	Red Jacket					Amps	Watts	Amps	Watts		Main	Start
2 Wire PSC	M05422	50C211	0.5	0.37	230	1.6	4.3	845	4.8	1035	16	6.1-7.2	-
	M07422	75C211	0.75	0.55		1.5	5.0	1100	6.4	1375	18	5.9-6.9	-
	M05422	100C211	1.0	0.75		1.4	6.7	1450	8.2	1770	23.5	4.2-5.2	-
	M15422	150C211	1.5	1.1		1.3	9.1	1950	10.5	2300	43	1.8-2.4	-
3 Wire	M05412	50C311	0.5	0.37		1.6	4.4	715	6.3	950	21	5.1-6.1	12.4-13.7
	M07412	75C311	0.75	0.55		1.5	4.6	920	8.3	1235	32	2.6-3.3	10.4-11.7
	M10412	100C311	1	0.75		1.4	6.2	1165	9.7	1490	41	2.0-2.6	9.3-10.4
	M15412	150C311	1.5	1.1	1.3	9.2	1660	11.1	2110	49	2.1-2.5	10.0-10.8	
	M20412	200C311	2	1.5	1.25	9.9	2170	68	2660	49	1.6-2.2	4.8-5.9	

The AQUAVAR SOLO²™ 1AS15 model 30-60 hertz speeds only.

The AQUAVAR SOLO²™ 3AS models provide the option of operating the system at either 30-60 or 30-80 hertz speeds.

Controller	30 - 60 Hertz (Standard Speed) Setting		30 - 80 Hertz (High Speed) Setting	
	Water End	Motor HP	Water End	Motor HP
3AS20	1	1	½	1
3AS20	1½	1½	¾	1½
3AS20	2	2	1	2
3AS30	1½	1½	¾	1½
3AS30	2	2	1	2
3AS30	3	3	1½	3
3AS50	5	5	3	5

When using the "80 hertz" setting with mis-matched water ends and motors, use the larger pump curve as the top curve. The bottom, or 30 hertz, curve is calculated using the smaller wet end curve and the Affinity Laws. The ProPak Bulletins define performance curves. See BGPROPAK60 or BGPROPAK80 for curves.

Xylem |'zīləm|

- 1) The tissue in plants that brings water upward from the roots;
- 2) a leading global water technology company.

We're a global team unified in a common purpose: creating advanced technology solutions to the world's water challenges. Developing new technologies that will improve the way water is used, conserved, and re-used in the future is central to our work. Our products and services move, treat, analyze, monitor and return water to the environment, in public utility, industrial, residential and commercial building services settings. Xylem also provides a leading portfolio of smart metering, network technologies and advanced analytics solutions for water, electric and gas utilities. In more than 150 countries, we have strong, long-standing relationships with customers who know us for our powerful combination of leading product brands and applications expertise with a strong focus on developing comprehensive, sustainable solutions.

For more information on how Xylem can help you, go to www.xylem.com



Xylem Inc.
2881 East Bayard Street Ext., Suite A
Seneca Falls, NY 13148
Phone: (866) 325-4210
Fax: (888) 322-5877
www.xylem.com/goulds

Xylem and AQUAVAR SOLO are registered trademarks of Xylem Inc. or one of its subsidiaries.
Goulds is a registered trademark of ITT Manufacturing Enterprises LLC and is used under license.
All other trademarks or registered trademarks are property of their respective owners.

© 2024 Xylem Inc. GWT-BAQSOLO2 R7 April 2024