

Additional Installation, Operation and
Maintenance Instructions



e-SHE, e-SHS Series

Horizontal Centrifugal Pump Units in AISI 316 Stainless Steel

Table of Contents

1	Introduction and Safety	5
1.1	Introduction	5
1.2	Safety	5
1.2.1	Danger levels and safety symbols	5
1.2.2	User safety	6
1.2.3	Protection of the environment.....	7
1.2.4	Sites exposed to ionizing radiations.....	7
2	Handling and Storage.....	8
2.1	Handling of the packed unit	8
2.2	Unit inspection upon delivery.....	9
2.3	Unit handling	9
2.4	Storage	11
3	Technical Description	12
3.1	Designation	12
3.2	Denomination of the models.....	12
3.3	Data plate	12
3.4	Identification code	13
3.5	Names of the main components	13
3.6	Intended use.....	14
3.7	Improper use	15
3.8	Use in water distribution networks for human consumption	15
3.9	Special applications	16
4	Installation	17
4.1	Precautions	17
4.2	Mechanical installation.....	18
4.2.1	Installation area	18
4.2.2	Permitted positions	18
4.2.3	Installation on concrete foundation.....	18
4.2.4	Fastening of the unit	19
4.2.5	Reducing vibrations	19
4.3	Hydraulic connection	20
4.3.1	Guidelines for the hydraulic system	20
4.4	Electrical connection	22
4.4.1	Ground.....	22
4.4.2	Guidelines for electrical connection.....	23
4.4.3	Guidelines for the electrical control panel	23
4.4.4	Guidelines for the motor	23
4.4.5	Operation with frequency converter	25

5	Use and operation	26
5.1	Precautions	26
5.2	Filling - Priming	27
5.2.1	Positive suction head installation	27
5.2.2	Suction lift installation	27
5.3	Rotation sense check (three-phase motors).....	28
5.3.1	Wrong rotation direction	28
5.4	Start-up	28
5.5	Stopping	29
6	Maintenance.....	30
6.1	Precautions	30
6.2	Tightening torques.....	31
6.3	Maintenance schedule	32
6.4	Long periods of inactivity.....	32
6.5	Spare parts ordering	32
7	Troubleshooting.....	33
7.1	Precautions	33
7.2	The unit does not start	33
7.3	The differential protection device (RCD) is activated	33
7.4	The thermal overload protection triggers or the fuses trip	33
7.5	The thermal overload protection triggers.....	34
7.6	The motor becomes excessively hot	34
7.7	The unit runs but there is little or no flow rate	34
7.8	When switched off, the unit turns in the opposite direction	34
7.9	The unit produces excessive noise and/or vibrations	35
7.10	The unit starts up too frequently (automatic start/stop).....	35
7.11	The unit never stops (automatic start/stop)	35
7.12	The unit is leaking	36
7.13	The frequency converter is in error mode or turned off.....	36
8	Technical Information	37
8.1	Operating environment	37
8.1.1	Downgrading the motor	38
8.2	Liquid temperature and maximum operating pressure	39
8.3	Maximum head.....	40
8.4	Maximum number of starts per hour.....	42
8.5	Protection class.....	43
8.6	Electrical specifications	43
8.7	Sound pressure	43
8.8	Materials in contact with the liquid	43
8.9	Mechanical seal	43
9	Disposal.....	44
9.1	Precautions	44

9.2	WEEE (EU/EEA)	44
9.3	WEEE (UK)	44
10	Declarations.....	45
10.1	Pump unit (electric pump)	45
10.2	Pump unit (electric pump)	46
11	Warranty	48
11.1	Information	48

1 Introduction and Safety

1.1 Introduction

Purpose of this manual

This manual provides information on how to do the following in the correct manner:

- Installation
- Operation
- Maintenance.



CAUTION:

This manual is an integral part of the unit. Make sure to have read and understood the manual before installing the unit and putting it to use. The manual must always be made available to the user, stored in the proximity of the unit, and well kept.

Supplementary instructions

The instructions and warnings of this manual apply to the standard unit as described in the sale documentation. Special version pumps may be supplied with supplementary instruction manuals. For situations not considered in the manual or in the sales document, contact Xylem or the Authorised Distributor.



1.2 Safety

1.2.1 Danger levels and safety symbols







Before using the unit, the user must read, understand and comply with the indications of the danger warnings in order to avoid the following risks:

- Injuries and health hazards
- Damage to the product
- Unit malfunction.

Danger levels

Hazard level	Indication
 DANGER:	It identifies a dangerous situation which, if not avoided, causes serious injury, or even death.
 WARNING:	It identifies a dangerous situation which, if not avoided, may cause serious injury, or even death.
 CAUTION:	It identifies a dangerous situation which, if not avoided, may cause small or medium level injuries.
NOTICE:	It identifies a situation which, if not avoided, may cause damage to property but not to people.

Complementary symbols

Symbol	Description
	Electrical hazard
	Hot surface hazard
	Danger, system pressurized
	Do not use flammable liquids
	Do not use corrosive liquids
	Read the instruction manual

1.2.2 User safety

Strictly comply with current health and safety regulations.



WARNING:

This unit must be used only by qualified users. Qualified users are people able to recognise the risks and avoid hazards during installation, use and maintenance of the unit.

Inexperienced users



WARNING:

- For EU countries: this product may be used by children aged 8 years and above and persons with reduced physical, sensory or mental capabilities, or who lack experience and knowledge, provided that they are being supervised and have been instructed on how to use it safely, and understand the hazards involved. Children must not play with the product. Cleaning and maintenance must not be carried out by children without supervision.
- For countries outside the EU: this product is not intended for use by persons (including children) with reduced physical, sensory or mental capabilities, or who lack experience and knowledge, unless they are being supervised and have been instructed on how to use it by a person responsible for their safety. Children should be supervised to ensure that they do not play with the product.

1.2.3 Protection of the environment

Disposal of packaging and product

Comply with the current regulations on sorted waste disposal.

Leaking of fluid

If the unit contains lubricating fluid, take appropriate measures to prevent the dispersion of leaks into the environment.

1.2.4 Sites exposed to ionizing radiations



WARNING: Ionizing radiation hazard

If the unit has been exposed to ionizing radiations, implement the necessary safety measures for the protection of people. If the unit needs to be despatched, inform the carrier and the recipient accordingly, so that appropriate safety measures can be put in place.

2 Handling and Storage

2.1 Handling of the packed unit



WARNING: Crushing hazard (limbs)

The unit and its components may be heavy: risk of crushing.



WARNING:

Always wear personal protective equipment.



WARNING:

Check the gross weight marked on the packaging.



WARNING:

Handle the unit in compliance with the current regulations on "manual load handling", to avoid undesirable ergonomic conditions causing risks of back-spine injury.



WARNING:

Take appropriate measures during transport, installation and storage to prevent contamination from external substances.

Depending on the model, the Manufacturer delivers the unit and its components in:

1. A cardboard box, or
2. A cardboard box with wooden base, or
3. A wooden crate.

Packaging type 2 and 3 are intended for transport with a forklift truck; the lifting points are indicated in the figure.

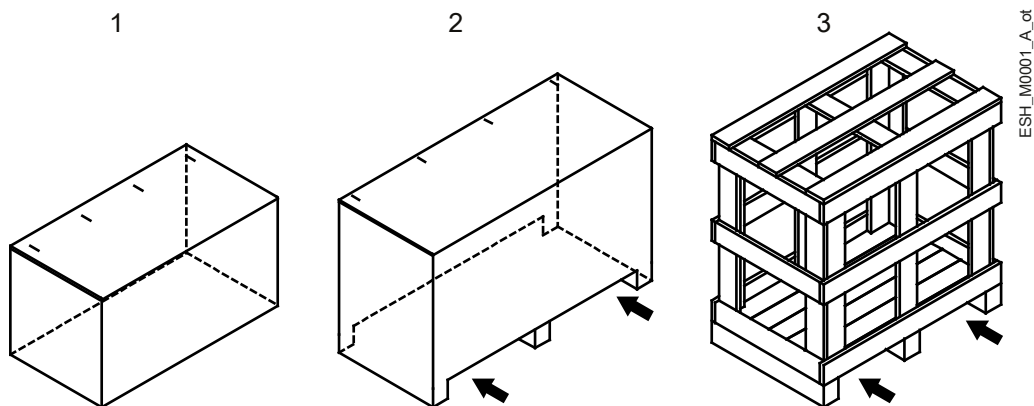

2.2 Unit inspection upon delivery

Inspect the package

1. Check that quantity, descriptions and product codes match the order.
2. Check the packaging for any damage or missing components.
3. In case of immediately detectable damage or missing parts:
 - accept the goods with reserve, indicating any findings on the transport document, or
 - reject the goods, indicating the reason on the transport document.

In both cases, promptly contact Xylem or the Authorised Distributor from whom the product was purchased.

Unpacking and inspection of the unit



CAUTION: Cut and abrasion hazard

Always wear personal protective equipment.

1. Remove packing materials from the product.
2. Release the unit by removing the screws and/or cutting the straps, if fitted.
3. Check the unit for integrity and to make sure that there are no missing components.
4. In case of damage or missing components, promptly contact Xylem or the Authorised Distributor.

2.3 Unit handling



WARNING:

Use cranes, ropes, lifting straps, hooks and clasps that comply with current regulations and that are suitable for the specific use.

NOTICE:

Make sure that the harnessing does not hit and/or damage the unit



WARNING:

Lift and handle the unit slowly to avoid stability issues.



WARNING:

During handling, make sure to avoid injury to people and animals, and/or damage to property.



WARNING:

Do not use eyebolts screwed on the motor for handling the unit.

The unit must be harnessed and lifted as shown in figures 1 and 2.

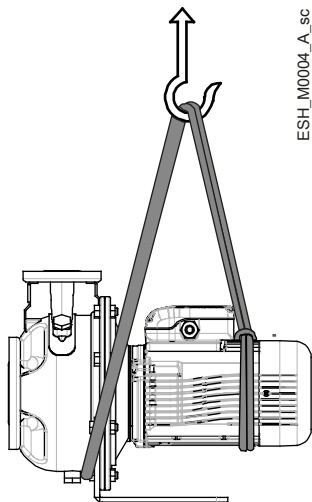

Figure 1: Lifting a unit with foot on the pump

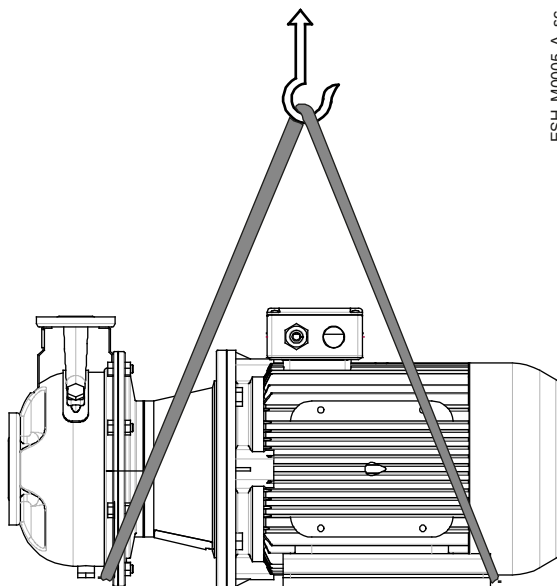

Figure 2: Lifting a unit with foot on the motor

2.4 Storage

Storage of the packed unit

The unit must be stored:

- In a covered and dry place
- Away from heat sources
- Protected from dirt
- Protected from vibrations
- At an ambient temperature between -5°C and +40°C (23°F and 140°F), and relative humidity between 5% and 95%.

NOTICE:

Do not place heavy loads on top of the unit.

NOTICE:

Protect the unit from collisions.

NOTICE:

Rotate the shaft by hand several times every three months.

Long-term storage of the unit

1. Empty the unit by unscrewing the drain plug; this operation is essential in environments with cold temperatures. Otherwise, any residual liquid in the unit could have an adverse effect on its condition and performance.

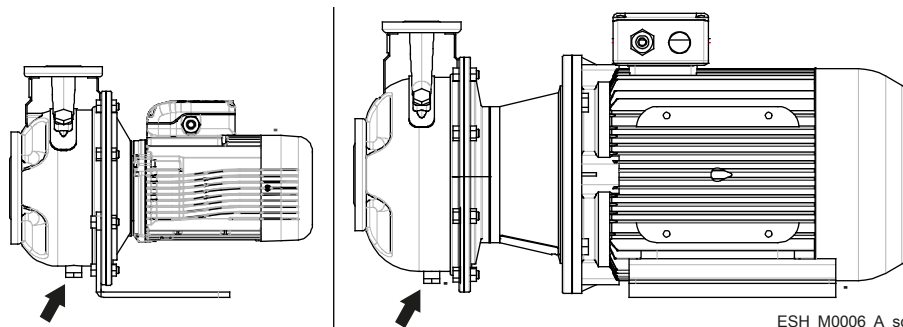

2. Follow the same instructions for the storage of the packed unit.

For more information on long-term storage contact the Xylem sales company or Authorised Distributor.

3 Technical Description

3.1 Designation

Horizontal centrifugal pump unit with end suction and radial discharge ports, in AISI 316 stainless steel.

3.2 Denomination of the models

Model	Description
ESHE	Close-coupled construction with an impeller keyed directly to the motor shaft extension
ESHS	Construction with a rigid coupling keyed to the standardised motor shaft extension

3.3 Data plate

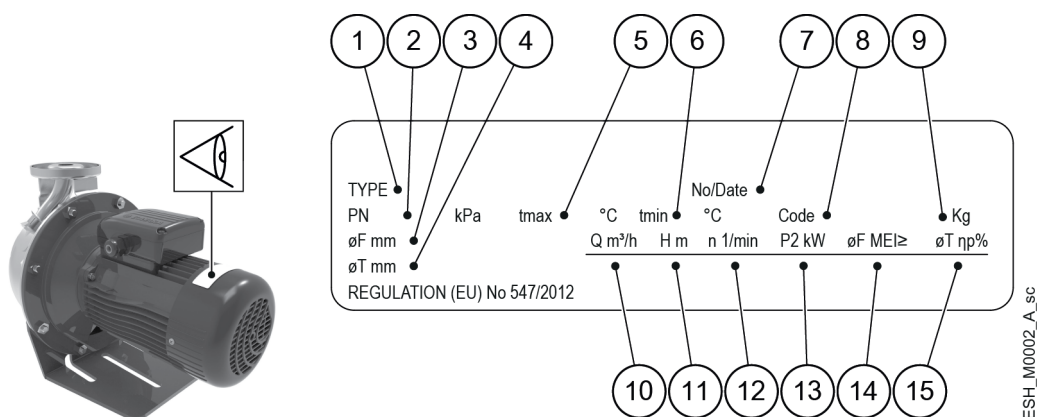

1. Pump unit type
2. Maximum operating pressure
3. Rated impeller diameter
4. Trimmed impeller diameter
5. Maximum liquid operating temperature
6. Minimum liquid operating temperature
7. Serial number + manufacturing date
8. Product code
9. Weight
10. Flow rate range
11. Head range
12. Speed
13. Rated or maximum power
14. Minimum efficiency index
15. Hydraulic efficiency in best efficiency point, at 50 Hz

3.4 Identification code

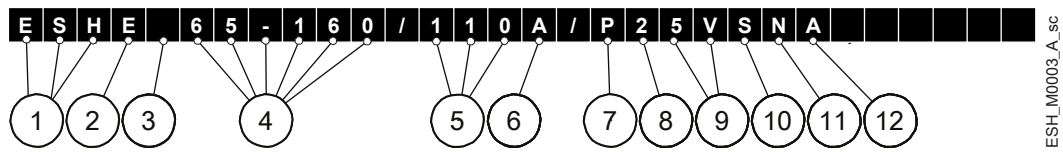

ESH_M0003_A_sc

1. Model denomination: ESHE or ESHS
2. Close-coupled [E] or rigid [S] coupling, or bare shaft []
3. Standard asynchronous motor [], with Hydrovar® [H] or with another drive [X]
4. Discharge piping diameter and impeller rated diameter, in mm
5. Rated motor power in kWx10
6. Trimmed impeller with reduced average diameter at the same rated power [A] or with reduced average diameter adapted to the duty point requested by the customer [X]
7. Type of motor
8. 2-pole [2] or 4-pole [4] motor
9. Electrical voltage with:
 - Frequency 50 Hz: 1x220-240 V [5H], 3x220-240/380-415 V [5R], 3x380-415/660-690 V [5V], 3x200-208/346-360 V [5P], 3x255-265/440-460 V [5S], 3x290-300/500-525 V [5T] or 3x440-460/- V [5W]
 - Frequency 60 Hz: 1x220-230 V [6F], 1x200-210 V [6E], 3x220-230/380-400 V [6P], 3x255-277/440-480 V [6R], 3x440-480/- V [6V], 3x380-400/660-690 V [6U], 3x200-208/346-360 V [6N] or 3x330-346/575-600 V [6T]
10. Pressed stainless steel pump body [S]
11. Impeller in pressed stainless steel [S] or cast stainless steel [N]
12. Material of the mechanical seal and OR configuration: ceramic/carbon/FKM [A], ceramic/carbon/EPDM [B], SiC/carbon/FKM [2], SiC/carbon/EPDM [4], SiC/SiC/FKM [W], SiC/SiC/EPDM [Z], other configurations [X]

Marks of safety approval

For products with a mark of electrical-related safety approval such as IMQ, TUV, IRAM, etc., the approval refers exclusively to the pump unit.

3.5 Names of the main components

e-SHE

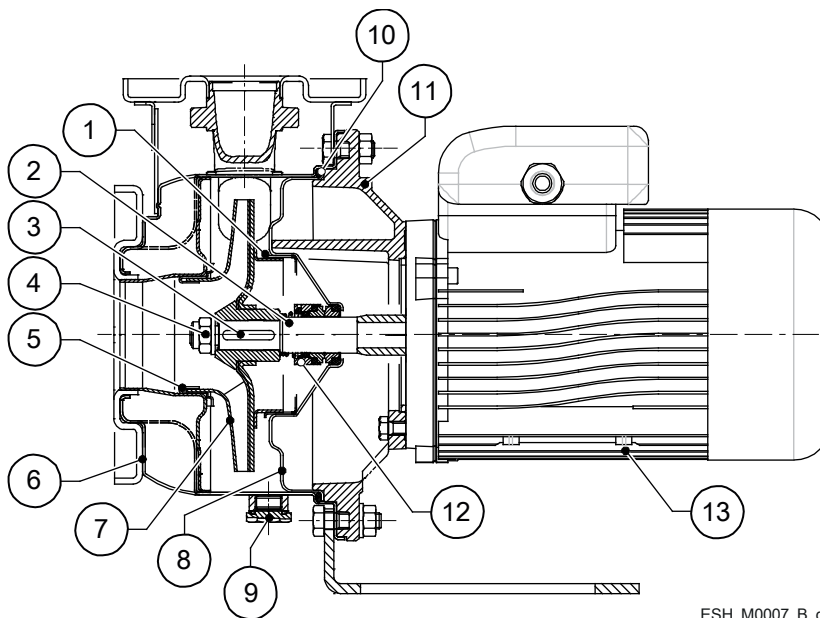

ESH_M0007_B_ds

e-SHS

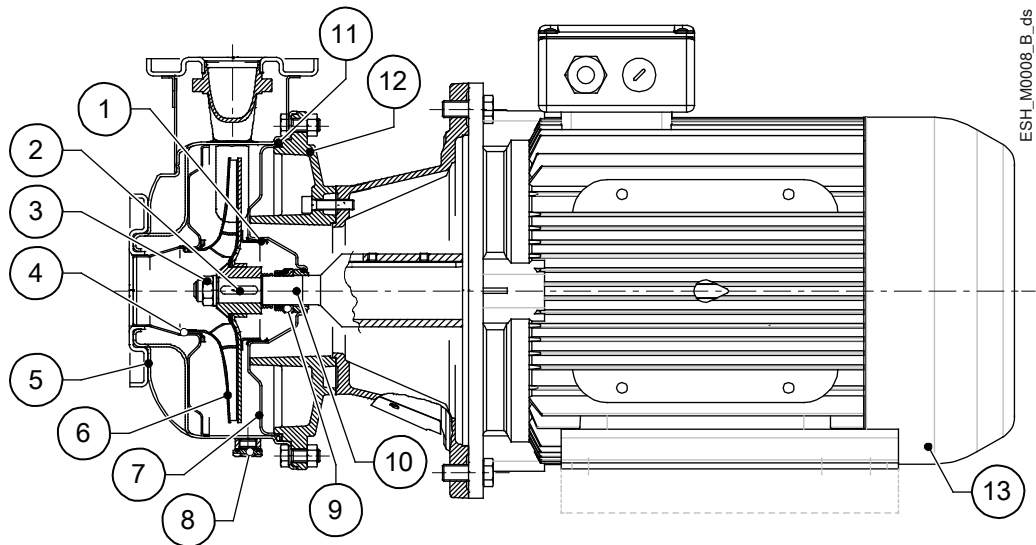

1. Counterwear ring
2. Impeller key
3. Impeller locking nut
4. Wear ring
5. Pump body
6. Impeller
7. Seal housing
8. Drain plug
9. Mechanical seal
10. Rigid coupling
11. Elastomers
12. Motor adapter
13. Motor

3.6 Intended use

- Water supply and water treatment
- Cooling and supply of hot water in civil and industrial systems
- Irrigation and sprinkler systems
- Heating systems.

Observe the operating limits in Technical Information on page 37.

Pumped liquids

- Clean
- Chemically and mechanically non aggressive
- Hot water
- Cold water.

3.7 Improper use



WARNING:

The unit was designed and built for the use described in the Intended Use section. Any other uses are prohibited, as they could compromise the safety of the user and the efficiency of the unit itself.



DANGER:

It is prohibited to use this unit to pump flammable and/or explosive liquids.



DANGER: Potentially explosive atmosphere hazard

It is prohibited to start the unit in environments with potentially explosive atmospheres or with combustible dusts.

Examples of improper use

- Pumping liquids not compatible with the construction materials of the unit
- Pumping hazardous, toxic, explosive, flammable or corrosive liquids
- Pumping drinking liquids other than water, for example wine or milk
- Pumping liquids containing abrasive, solid, or fibrous substances
- Using the unit for flow rates exceeding the flow rate indicated in the data plate.

Examples of improper installation

- Explosive and corrosive atmospheres
- Areas where the air temperature is very high and/or there is poor ventilation
- Outdoor without protection from weather conditions.

3.8 Use in water distribution networks for human consumption

If the unit is intended for water supply to people and/or animals:



WARNING:

It is prohibited to pump drinking water after use with other fluids.



WARNING:

Take appropriate measures during transport, installation and storage to prevent contamination from external substances.



WARNING:

Remove the unit from its packaging just before installation to prevent contamination from external substances.



WARNING:

After installation, run the unit for a few minutes with several users open in order to wash the inside of the system.

3.9 Special applications

Contact Xylem or the Authorised Distributor in the following cases:

- If liquids with a density and/or viscosity value exceeding that of water (such as water and glycol mixture) must be pumped
- If the pumped liquid is chemically treated (for example softened, deionized, demineralized etc.)
- Any situations different from the ones described and relating to the nature of the liquid.

4 Installation

4.1 Precautions

Before starting, make sure that the safety instructions shown in **Introduction and Safety** on page 5 have been fully read and understood.



DANGER:

All the hydraulic and electrical connections must be completed by a technician possessing the technical-professional requirements outlined in the current regulations.



DANGER: Potentially explosive atmosphere hazard

It is prohibited to start the unit in environments with potentially explosive atmospheres or with combustible dusts.



WARNING:

Always wear personal protective equipment.



WARNING:

Always use suitable working tools.



WARNING:

When selecting the place of installation and connecting the unit to the hydraulic and electric power supplies, strictly comply with current regulations.

When connecting the unit to a public or private aqueduct, or to a well for the supply of water for human and/or animal consumption, see **Use in water distribution networks for human consumption** on page 15.

4.2 Mechanical installation

Install the unit on a concrete or metal foundation base sufficiently strong to ensure permanent and rigid support.

4.2.1 Installation area

1. Follow the provisions in **Operating environment** on page 37.
2. Place the unit in a raised position in relation to the floor.
3. Make sure that any leaks will not cause flooding to the installation area or submerge the unit.
4. In case of installation of the unit outdoors, ensure appropriate protection of the motor against direct sunlight, rain and snow; see figure.

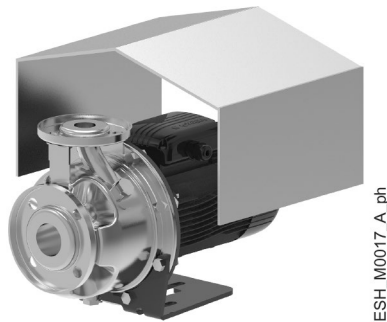

Air clearance between a wall and the motor fan grille

- To ensure suitable ventilation: ≥ 100 mm (4 in)
- To permit inspection and removal of the motor: see technical catalogue.

4.2.2 Permitted positions

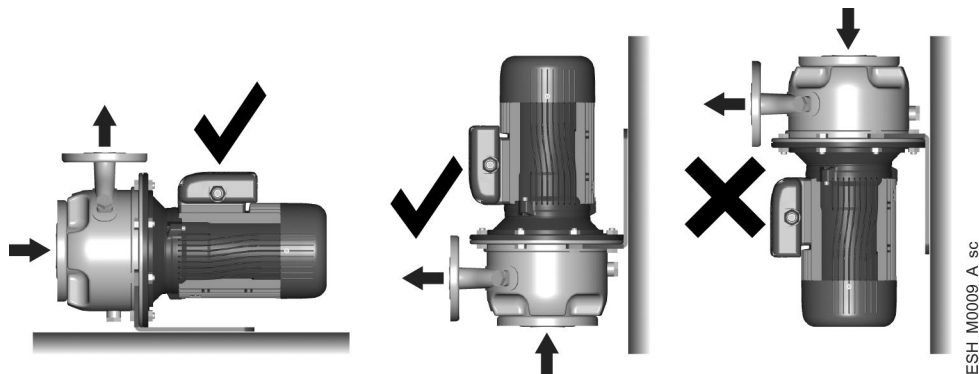

4.2.3 Installation on concrete foundation

Requirements

- The concrete must have a compression resistance of C12/15 and meet the requirements of exposure class XC1 according to EN 206-1
- The foundation weight must be ≥ 1.5 times the unit weight (≥ 5 times the weight of the unit if a quieter operation is required)
- The surface should be as flat and as horizontal, or vertical, as possible.

4.2.4 Fastening of the unit

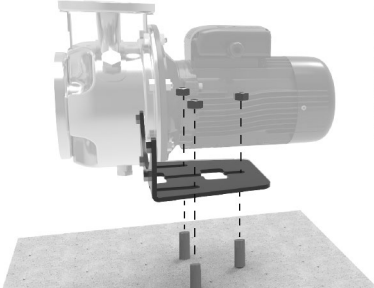
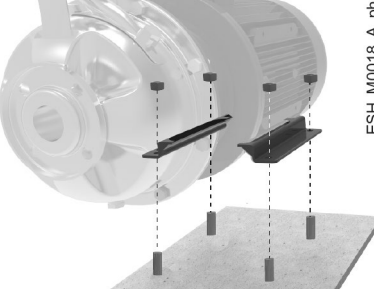
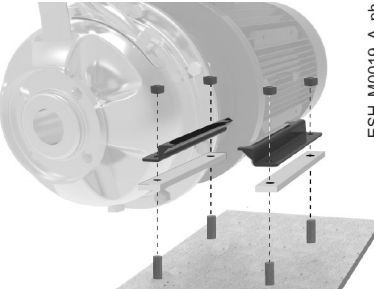
Phase	Action	Illustration
1	If present, remove the plugs covering the suction and discharge ports.	 <p style="text-align: right; font-size: small;">ESH_M0012_A_ph</p>
2	Place the unit on the foundation.	
3	Align the suction and discharge ports to their piping.	
4a	Unit with foot on the pump: secure with 3 bolts with resistance class 8.8 or higher.	 <p style="text-align: right; font-size: small;">ESH_M0011_A_ph</p>
4b	Unit with foot on the motor: secure with 4 bolts with resistance class 8.8 or higher.	 <p style="text-align: right; font-size: small;">ESH_M0018_A_ph</p>
4c	Unit with motor size from 160 to 200, 2 poles and 160, 4 poles: insert the 2 shims and secure with 4 bolts with resistance class 8.8 or higher.	 <p style="text-align: right; font-size: small;">ESH_M0019_A_ph</p>

4.2.5 Reducing vibrations

The motor and the flow of liquids in the pipes may cause vibrations, which can be exacerbated by incorrect installation of the unit and pipes. See **Hydraulic connection** on page 20.

4.3 Hydraulic connection



DANGER:

All the hydraulic and electrical connections must be completed by a technician possessing the technical-professional requirements outlined in the current regulations.



WARNING:

Piping must be sized to ensure safety at the maximum operating pressure.



WARNING:

Install appropriate seals between the unit couplings and the pipings.

4.3.1 Guidelines for the hydraulic system

The figures show the hydraulic reference diagrams for positive suction head and suction lift installations.

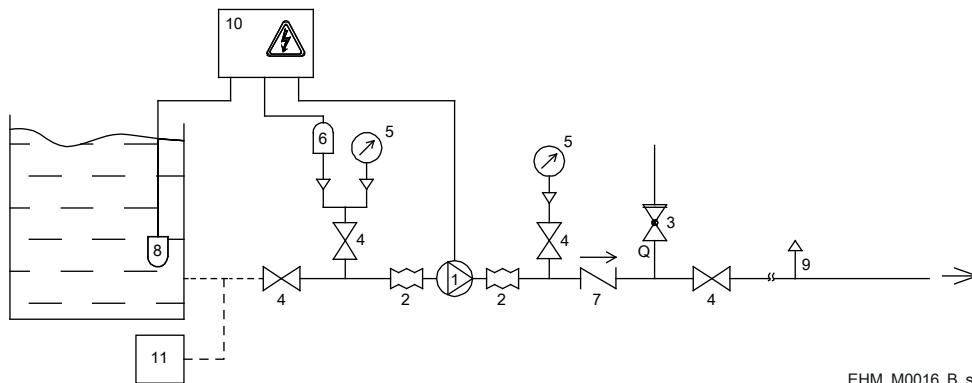

EHM_M0016_B_sc

Figure 3: Positive suction head installation

1. Pump unit
2. Anti-vibration joint
3. Overpressure safety on-off valve
4. On-off valve
5. Pressure gauge
6. Minimum pressure switch
7. Check valve
8. Electrode probes or float
9. Automatic relief valve
10. Electric panel
11. Pressurised circuit.

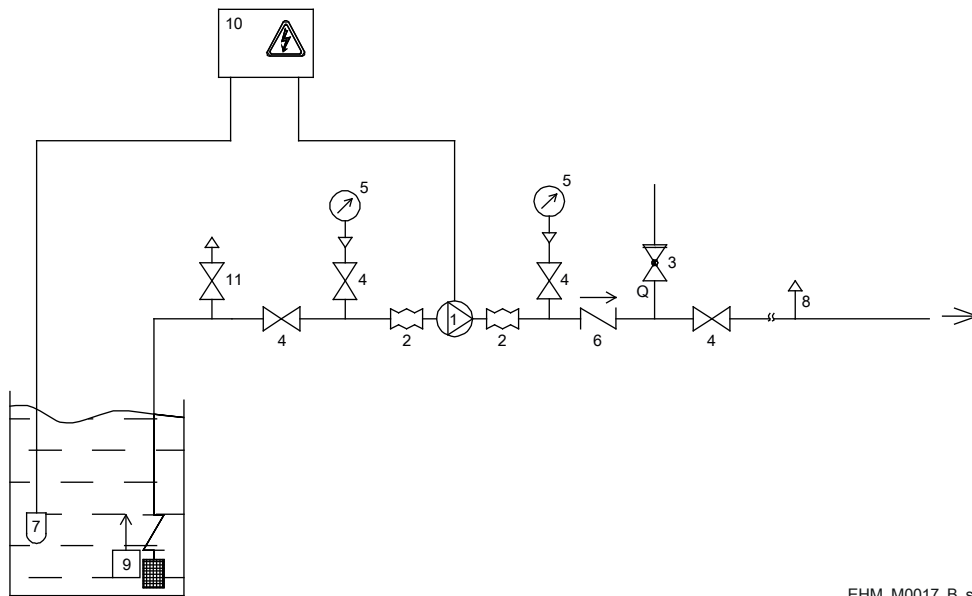

Figure 4: Suction lift installation

1. Pump unit
2. Anti-vibration joint
3. Overpressure safety on-off valve
4. On-off valve
5. Pressure gauge
6. Check valve
7. Electrode probes or float
8. Automatic relief valve
9. Foot check valve with filter
10. Electric panel
11. Filling on-off valve.

General guidelines

1. Refer to the hydraulic diagrams.
2. Do not install the unit at the lowest point of the system, to avoid the accumulation of sediments.
3. Support the pipes independently to prevent them from weighing on the unit.
4. Fit dampers between the unit and the surface on which it is installed, to reduce the transmission of vibrations from the unit to the system and vice versa.
5. Remove any welding residues, deposits and impurities in the pipes that could damage the unit; install a filter if necessary.
6. Install an automatic relief valve at the highest point of the system to eliminate air bubbles.

Guidelines for the suction side

To reduce flow resistance, the piping must be:

- As short and as straight as possible
- For the section connected to the unit, straight and without bottlenecks, covering a length equal to at least six times the diameter of the suction port
- Wider than the suction port; if necessary, install an eccentric reducer that is horizontal on top
- Without bends; if this cannot be avoided, bends of a radius as wide as possible
- Without traps and 'goosenecks'
- With on-off valves with a low specific flow resistance.

In addition:

1. Install a device to prevent the absence of liquid, for example a float or probes, or a minimum pressure device.
2. Submerge the end of the pipe in the liquid, in order to prevent any air from penetrating through the suction vortex when the level is at the minimum
3. In case of positive suction head installation, install a pressure gauge

4. In case of suction lift installation, the piping must have an increasing slope towards the unit exceeding 2%; to avoid air pockets. Also install:
 - A vacuum pressure gauge
 - A foot check valve that guarantees full opening (full section)
 - A filling on-off valve to facilitate the removal of the air and priming.
5. Install an on-off valve to exclude the unit from the system during maintenance.
6. Install anti-vibration joints to reduce the transmission of vibrations between the unit and the system and vice versa.

Guidelines for the discharge side

1. Install a check valve to prevent the liquid from flowing back into the unit when this is at standstill.
2. Install a pressure gauge.
3. Install an on-off valve, downstream from the check valve and pressure gauge, to regulate the flow rate.
4. Install anti-vibration joints to reduce the transmission of vibrations between the unit and the system and vice versa.

4.4 Electrical connection



DANGER:

All the hydraulic and electrical connections must be completed by a technician possessing the technical-professional requirements outlined in the current regulations.



DANGER: Electrical hazard

Before starting work, check that the unit is unplugged and that the pump unit, the control panel and the auxiliary control circuit cannot restart, even unintentionally.

NOTICE:

Before starting work, make sure that the general electric requirements and/or those of the firefighting systems (hydrants or sprinklers) comply with local regulations.

4.4.1 Ground



DANGER: Electrical hazard

Always connect the external protection conductor (ground) to the ground terminal before attempting to make any other electrical connections.



DANGER: Electrical hazard

Connect all the electrical accessories of the pump unit and motor to the ground.



DANGER: Electrical hazard

Check that the external protection conductor (ground) is longer than the phase conductors; In case of accidental disconnection of the unit from the phase conductors, the protection conductor must be the last one to detach itself from the terminal.



DANGER: Electrical hazard

Install suitable systems for protection against indirect contact, in order to prevent lethal electric shocks.

4.4.2 Guidelines for electrical connection

1. Check that the electrical leads are protected against:
 - High temperature
 - Vibrations
 - Collisions.
2. Check that the power supply line is provided with:
 - A short circuit protection device of appropriate size
 - A mains disconnection device with contact opening distance ensuring complete disconnection for overvoltage III category conditions.

4.4.3 Guidelines for the electrical control panel

NOTICE:

The electric panel must match the ratings on the unit data plate. Improper combinations could damage the motor.

1. Install appropriate devices for protecting the motor from overloads and short circuits:

Protection	Motor		Notes
	Single-phase	Three-phase	
Automatic reset thermal-ampere protection	•	-	Built-in (motor protector)
Thermal: trip class 10 A overload thermal relay + aM fuses (motor starting), or start class 10 A motor protection thermal magnetic switch	-	•	To be supplied by the installer
From short circuit: aM fuses (motor start-up), or thermal magnetic switch with C curve and $I_{cn} \geq 4.5 \text{ kA}$, or other similar device	•	•	

2. Fit a system for protection against dry running to which to connect a pressure switch, or a float, probes or other suitable devices.
3. On the suction side install:
 - A pressure switch, in the case of connection to the mains water supply
 - A float switch or probes, in the case of liquid drawn from a tank or basin.
4. If required, install phase failure sensitive thermal relays.

4.4.4 Guidelines for the motor

If using a motor other than the standard motor, check that a thermal protection device has been installed.



WARNING: Injuries hazard

The unit, equipped with a single-phase motor with automatic reset thermal overload protection, could restart inadvertently after it has cooled down: risk of physical injury.



WARNING:

The use of units with single-phase motors with automatic reset thermal protection for extinguishing fires and in pulverised water firefighting systems is forbidden.

NOTICE:

Only use dynamically balanced motors with half-sized key at the shaft end (IEC 60034-14), and with normal vibration rate (N).

NOTICE:

Only use single-phase or three-phase motors with sizes and powers in compliance with European standards.

NOTICE:

The mains voltage and frequency must match the specifications on the data plate.

Electrical connection of the motor

1. Open the terminal box cover.
2. Insert the power cable in the cable gland on the terminal board.
3. Unsheathe the conductors.
4. Referring to the figure below or to the wiring diagram inside the cover:
 - Connect the protection conductor (ground), making sure that it is longer than the phase conductors
 - Connect the phase leads.

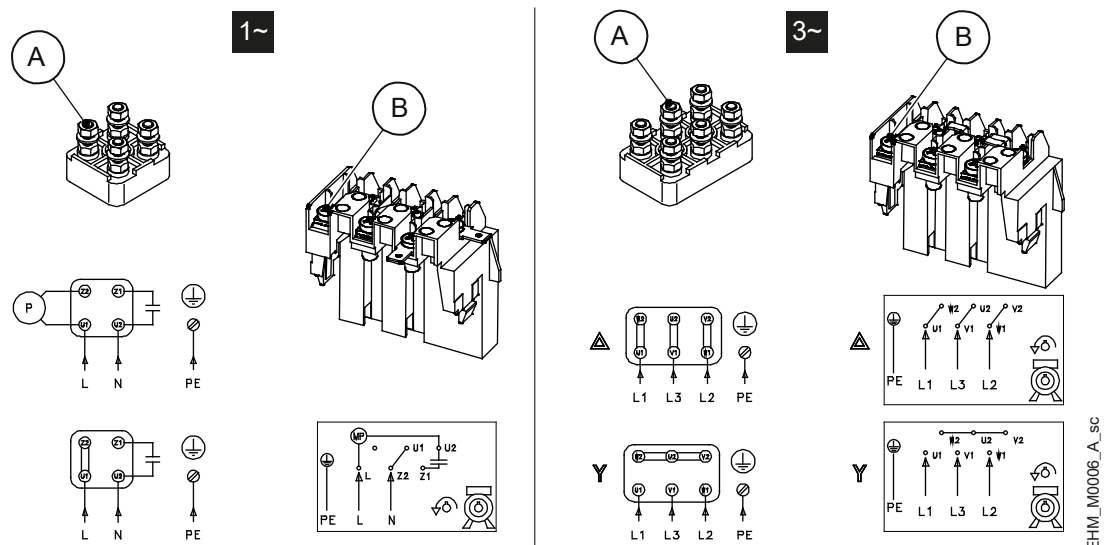

Position	Bolt size	Torque, Nm (lbf-in)
A	M4	1.2 (11)
	M5	2.5 (22)
	M6	4.0 (35)
	M8	8.0 (71)
	M10	15.0 (133)
B	M4	1.2 (11)

5. Tighten the cable gland.
6. Close the terminal box cover and tighten all the screws; see Tightening torques on page 31.

Motor without automatic reset thermal overload protection

- If the motor is used with full load, then set the value to the nominal current value on the data plate of the pump unit.
- If the motor is used with partial load, then set the value of the operating current measured with a current pincer.
- For three-phase motors with star-delta starting system, set the thermal relay downstream of the switching circuit at 58% of the rated or operating current.

4.4.5 Operation with frequency converter

The three-phase motors can be connected to a frequency converter for speed control.

- The converter exposes the insulation of the motor to a greater load, determined by the length of the connecting cable: observe the requirements of the Manufacturer of the frequency converter
- For applications requiring silent operation, install an outlet filter between the motor and the converter; a sinusoidal filter can reduce the noise even further
- The bearings of the motors, from size 315 S/M and up, are exposed to the risk of harmful currents: use electrically insulated bearings
- The conditions of installation must guarantee protection against voltage peaks between the terminals and/or dV/dt in the table:

Motor size	Voltage peak, V	dV/dt , V/ μ s
up to 90R (500 V)	< 650	< 2200
from 90R to 180R	< 1400	< 4600
over 180R	< 1600	< 5200

Otherwise, use a motor with reinforced insulation¹ and a sinusoidal filter.

¹ Available on request

5 Use and operation

5.1 Precautions



WARNING: Injuries hazard

Check that the protection devices of the coupling are installed, when applicable: risk of physical injury.



WARNING:

Make sure that the drained liquid cannot cause damage or injuries.



WARNING: Electrical hazard

Check that the unit is properly connected to the mains power supply.



WARNING: Injuries hazard

The unit, equipped with a single-phase motor with automatic reset thermal overload protection, could restart inadvertently after it has cooled down: risk of physical injury.



WARNING: Hot surface hazard

Be aware of the extreme heat generated by the unit.



WARNING:

It is prohibited to put combustible materials near the unit.

NOTICE:

Check that the shaft can turn smoothly.

NOTICE:

It is prohibited to operate the unit when dry, not primed and below the minimum rated flow rate.

NOTICE:

It is prohibited to operate the unit with the on-off valves on the suction and discharge sides closed.

NOTICE:

It is prohibited to use the unit in the case of cavitation.

NOTICE:

The unit must be filled and vented properly before it can be started.

NOTICE:

The maximum pressure delivered by the unit at the discharge side, determined by the pressure available on the suction side, must not exceed the maximum pressure (PN).

5.2 Filling - Priming



WARNING:

In the case of liquids that are excessively hot or cold, pay attention to the risk of injury.

The figure shows the unit connected to the discharge and suction pipes.

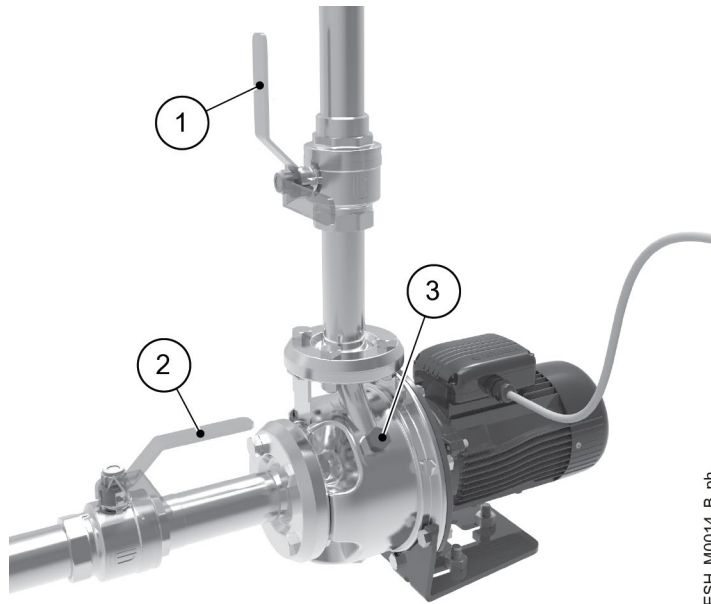

1. On-off valve, discharge side
2. On-off valve, suction side
3. Filling plug.

5.2.1 Positive suction head installation

1. Close both valves.
2. Loosen the plug.
3. Slowly open the valve on the suction side until the liquid regularly comes out from the hole; if necessary, loosen the plug further.
4. Close the plug.
Tightening torque: 40 Nm (350 lbf-in) \pm 15%.

5.2.2 Suction lift installation

1. Open the valve on the suction side and close the valve on the discharge side.
2. Remove the plug.
3. Fill the unit until the liquid comes out of the hole.
4. Wait a few minutes and top up with more liquid if necessary.
5. Close the plug
Tightening torque: 40 Nm (350 lbf-in) \pm 15%.

5.3 Rotation sense check (three-phase motors)

Before starting the unit:

NOTICE:

Check that the shaft can turn smoothly.

The figure shows the motor fan cover.



1. Locate the arrow on the fan cover, the adapter or the coupling, to determine the correct direction of rotation of the motor.
2. Start the unit.
3. Check the direction of rotation through the grid on the fan cover or through the coupling protection.
4. Stop the unit.

5.3.1 Wrong rotation direction

1. Disconnect the power supply.
2. Invert two of the three wires of the power supply cord.

5.4 Start-up

NOTICE:

It is prohibited to operate the unit with the discharge side on-off valve closed or at zero flow rate: this can cause the liquid to overheat and damage the unit.

NOTICE:

If there is a risk of the unit running at a flow rate below the minimum expected, install a bypass circuit.

NOTICE:

Check that the shaft can turn smoothly.

1. Check that all the operations described in the previous paragraphs have been completed correctly.
2. Shut off the discharge on-off valve almost completely.
3. Fully open the suction on-off valve.
4. Start the unit.
5. Gradually open the discharge on-off valve until half open.
6. Wait a few minutes and then fully open the discharge on-off valve.

After the start-up procedure, with the pump unit in operation, check that:

- No liquid is leaking from the unit or pipes
- The maximum pressure of the unit at the discharge, determined by the available suction pressure, must not exceed the maximum pressure (PN)
- The current absorbed is within the rated limits (calibrate the thermal overload protection of the motor)
- There is no unwanted noise or vibrations
- At zero flow rate, the pressure at the discharge corresponds to the expected nominal pressure
- No vortexes can occur at the end of the suction pipe, at the point of the foot check valve (suction lift installation).

NOTICE:

If the unit does not deliver the required pressure, repeat the operations in **Filling - Priming** on page 27.



WARNING:

After startup, run the unit for a few minutes with several users open in order to wash the inside of the system.

Settling of the mechanical seal

The pumped liquid lubricates the seal faces of the mechanical seal; under normal conditions, a small amount of liquid may leak out. When the unit is run for the first time, or immediately after the seal is replaced, more liquid may temporarily leak out. To help the seal settle and to reduce leaking:

1. Close and open the on-off valve on the discharge side two or three times with the unit running.
2. Stop and start the unit two or three times.

5.5 Stopping

1. Shut the on-off valve located on the discharge line.
2. Stop the pump unit and check that the motor slows down gradually.
3. Gradually re-open the valve and check that the motor remains still.

6 Maintenance

6.1 Precautions

Before starting, make sure that the instructions shown in **Introduction and Safety** on page 5 have been fully read and understood.



WARNING:

Maintenance must be done by a technician possessing the technical-professional requirements outlined in the current regulations.



WARNING:

Always wear personal protective equipment.



WARNING:

Always use suitable working tools.



WARNING:

In the case of liquids that are excessively hot or cold, pay attention to the risk of injury.



DANGER: Electrical hazard

Before starting work, check that the unit is unplugged and that the electric pump, the control panel and the auxiliary control circuit cannot restart, even unintentionally.



DANGER: Electrical hazard

If the unit is connected to the frequency converter, disconnect the mains power supply and wait at least 10 minutes for the residual current to dissipate.

6.2 Tightening torques

The figure shows the threaded fittings of the unit.

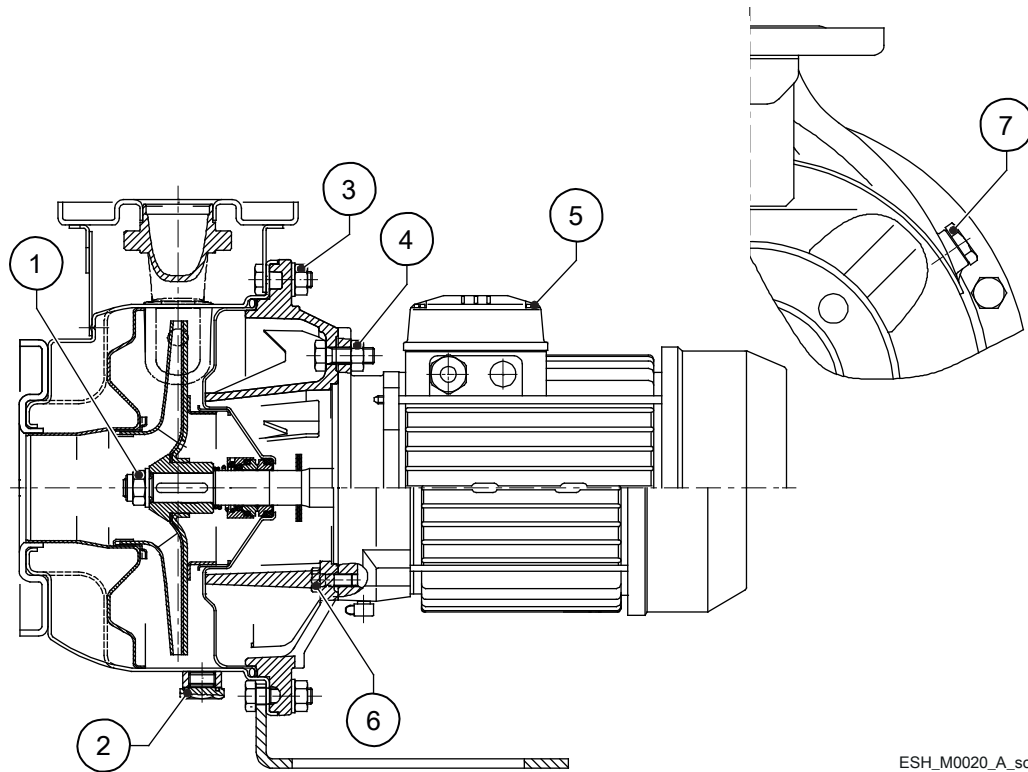

ESH_M0020_A_sc

Position number	Size	Torque, Nm (lbf-in)
1	M12	45 (400) ± 15%
	M16	110 (970) ± 15%
	M20	200 (1770) ± 15%
2	G3/8	40 (350) ± 25%
3	M10	40 (350) ± 15%
	M12	70 (620) ± 15%
4	M10	32 (280) ± 15%
	M12	50 (440) ± 15%
	M16	110 (970) ± 15%
5	M3.5	2 (18) ± 25%
	M5	3 (27) ± 25%
	M6	4 (35) ± 25%
	M8	11 (97) ± 25%
	M10	24 (210) ± 25%
	M12	32 (280) ± 25%
	M14	37 (330) ± 25%
	M16	42 (370) ± 25%
	Ø3.5	2 (18) ± 25%
	Ø4.2	1.2 (13) ± 25%
Ø6	4 (35) ± 15%	
6	M8	15 (130) ± 15%
	M10	32 (280) ± 15%
	M12	45 (400) ± 15%
7	G3/8	40 (350) ± 15%

6.3 Maintenance schedule

Maintenance intervals are only valid if the unit has been selected and installed according to Xylem guidelines.

Type of maintenance	Purpose	Interval
Periodic check of the system	<ul style="list-style-type: none"> Check for liquid leaks Check the tightness of the screws and bolts 	Every 4000 hours of operation or every year, when the first of the two limits is reached
Periodic check of the pump	<ul style="list-style-type: none"> Measure the pressure at zero flow rate and compare it with the pressure measured during initial start-up; if the pressure has decreased by more than 15%, check the condition of impeller, pump body and wear rings Check for unwanted noise and vibrations 	
Periodic check of the motor	<ul style="list-style-type: none"> Check that the insulation resistance is greater than 500 MΩ, applying a test voltage of 500 Vdc for 1 minute Check the terminal board for any signs of overheating and arc flashes Check the condition of the cooling fan and clean it 	
Replacement	<ul style="list-style-type: none"> Replace the mechanical seal Replace the O-ring 	Every 20000 hours of operation or every 2 years, when the first of the two limits is reached
Replacement	Replace the motor bearings (only for greased for life bearings)	Every 20000 hours of operation or every 5 years, when the first of the two limits is reached
Topping up or replacement	Top up or replace motor bearing grease (only for regreaseable bearings)	Refer to the data plate and instructions of the motor for information on the type of grease and how often it needs to be topped up or replaced

6.4 Long periods of inactivity

1. Close the on-off valve on the suction side.
2. Completely empty the unit.
3. Protect the unit against freezing.
4. Rotate the shaft by hand several times every three months.
5. Before restarting the unit, check that the shaft is rotating freely, without mechanical impediments.

6.5 Spare parts ordering

Contact Xylem or the Authorised Distributor for technical information.

7 Troubleshooting

7.1 Precautions



WARNING:

Maintenance must be done by a technician possessing the technical-professional requirements outlined in the current regulations.



WARNING:

Observe the safety instructions given in Use and operation and Maintenance.



WARNING:

If a fault cannot be corrected or is not mentioned, contact Xylem or the Authorised Distributor.

7.2 The unit does not start

Cause	Solution
Power supply cut off	Restore the power supply
The thermal overload protection of the motor has been triggered	Reset the thermal overload protection on the control panel or the unit
The device that detects the absence of liquid or minimum pressure has been triggered	Top up the liquid or restore minimum pressure
The capacitor, if present, is faulty	Replace the capacitor
Control panel faulty	Check and repair or replace the control panel
Motor (coil) faulty	Check and repair or replace the motor

7.3 The differential protection device (RCD) is activated

Cause	Solution
Motor leaking	Check and repair or replace the motor
Unsuitable type of differential	Check the type of differential

7.4 The thermal overload protection triggers or the fuses trip

The motor thermal overload protection triggers or the fuses trip when the unit starts.

Cause	Solution
It is calibrated at a value too low in relation to the rated current of the motor	Recalibrate
Missing power supply phase	Check the power supply and restore the phase
Loose and/or faulty connections of the thermal overload protection	Tighten or replace the clamps and terminals
Loose and/or incorrect and/or faulty (star-delta) connections in the terminal board of the motor	Tighten or replace the clamps and terminals
Motor (coil) faulty	Check and repair or replace the motor
Pump unit mechanically seized	Check and repair the pump unit
Check valve faulty	Replace the check valve
Foot check valve faulty	Replace the foot check valve

7.5 The thermal overload protection triggers

The motor thermal overload protection triggers occasionally, or after the unit has been running for a few minutes.

Cause	Solution
It is calibrated at a value too low in relation to the rated current of the motor	Recalibrate
Input voltage outside the rated limits	Make sure the voltage values are correct
Unbalanced input voltage	Make sure the voltage of the three phases is balanced
Incorrect working curve (flow rate greater than the maximum permitted flow rate)	Reduce the required flow rate
Liquid too dense, presence of solid or fibrous substances (unit overloaded)	<ul style="list-style-type: none"> • Reduce the density of the liquid and/or • Remove the solid substances and/or • Increase the size of the motor
Room temperature too high, exposure to sunlight	<ul style="list-style-type: none"> • Lower the temperature at the point of the thermal overload protection and/or • Protect against direct sunlight
Unit faulty	Send the unit to an authorised workshop for testing

7.6 The motor becomes excessively hot

Cause	Solution
Room temperature outside the rated limits	Lower the room temperature
Cooling fan of the motor clogged or damaged	Clean or replace the cooling fan
The unit starts up too frequently	See the section: The unit produces excessive noise and/or vibrations
The frequency converter, if present, has not been calibrated properly	See the frequency converter manual

7.7 The unit runs but there is little or no flow rate

Cause	Solution
Motor turns in the wrong direction	Check the direction of rotation and change it if necessary
Incorrect priming (there are air bubbles in the suction pipe or in the unit)	Repeat the priming procedure
Cavitation	Increase the NPSH ² available in the system
Check valve locked in closed or partially closed position	Replace the check valve
Foot check valve locked in closed or partially closed position	Replace the foot check valve
Discharge pipe throttled	Remove the throttling
Piping and/or unit clogged	Remove the clogging

7.8 When switched off, the unit turns in the opposite direction

Cause	Solution
Check valve faulty	Replace the check valve
Foot check valve faulty	Replace the foot check valve

² Net Positive Suction Head

7.9 The unit produces excessive noise and/or vibrations

Cause	Solution
Cavitation	Increase the NPSH ³ available in the system
Unsuitable fastening	Check fastening
Resonance	Check the installation
Anti-vibration joints not installed	Install anti-vibration joints on the suction and discharge sides of the unit
Foreign bodies in the unit	Remove the foreign bodies
Motor bearings worn or faulty	Replace the motor bearings
The unit does not turn freely due to a mechanical fault	Send the unit to an authorised workshop for testing

7.10 The unit starts up too frequently (automatic start/stop)

Cause	Solution
Incorrect priming (there are air bubbles in the suction pipe or in the unit)	Repeat the priming procedure
Check valve locked in closed or partially closed position	Replace the check valve
Foot check valve locked in closed or partially closed position	Replace the foot check valve
Starter (pressure switch, sensor, etc.) set incorrectly, or faulty	Adjust or replace the starter
Expansion vessel <ul style="list-style-type: none"> no pre-charge, or undersized, or not installed 	<ul style="list-style-type: none"> Pre-charge the expansion vessel, or replace the expansion vessel with another suitable one, or install an expansion vessel
Oversized unit	Contact Xylem or the Authorised Distributor

7.11 The unit never stops (automatic start/stop)

Cause	Solution
The required flow rate is greater than the one expected	Reduce the required flow rate
Discharge pipe leaking	Eliminate the leaks
Motor turns in the wrong direction	Check the direction of rotation and change it if necessary
Pipes, on-off valves or filter clogged with impurities	Remove the impurities
Starter (pressure switch, sensor, etc.) set incorrectly, or faulty	Adjust or replace the starter
The unit runs but there is little or no flow rate	See the section: The thermal overload protection triggers

³ Net Positive Suction Head

7.12 The unit is leaking

Cause	Solution
Worn mechanical seal	Replace the mechanical seal, or Fit a mechanical seal with harder seal faces
Mechanical seal damaged due to thermal shock (presence of air bubbles in the unit)	Replace the mechanical seal
Defective mechanical seal	Replace the mechanical seal
Mechanical seal damaged due to temperature of the liquid outside the rated limits	Replace the mechanical seal with another of a suitable make
Mechanical seal damaged due to chemical incompatibility with the liquid	Replace the mechanical seal with one of a make chemically compatible with the pumped liquid

7.13 The frequency converter is in error mode or turned off

The frequency converter (if present) is in error mode or turned off

Cause	Solution
See the frequency converter manual	See the frequency converter manual

8 Technical Information

8.1 Operating environment

Non-aggressive and non-explosive atmosphere.

Temperature

The table shows the temperatures according to the motor characteristics.

Phase ~	Number of poles	Power, kW	Temperature, °C (°F)
1	All		0 - 40 (32 - 104)
3	4	0.25 to 0.75	0 - 50 (32 - 122)
		1.1 to 15.0	
	2	0.75 to 22.0	

NOTICE: Danger of motor overheating

If the unit is exposed to temperatures higher than those indicated, reduce the motor power; see **Downgrading the motor**.

Otherwise, replace the motor with a more powerful one.

Relative air humidity

< 50% at 40°C (104°F).

NOTICE:

If the humidity exceeds the stated limits, contact Xylem or the Authorised Distributor.

Elevation

< 1000 m (3300 ft) above sea level.

NOTICE: Danger of motor overheating

If the unit is exposed to temperatures higher than those indicated, reduce the motor power; see **Downgrading the motor**.

Otherwise, replace the motor with a more powerful one.

8.1.1 Downgrading the motor

The following diagram shows the downgrading coefficients k_T according to the ambient temperature; ET is the maximum ambient temperature indicated on the data plate.

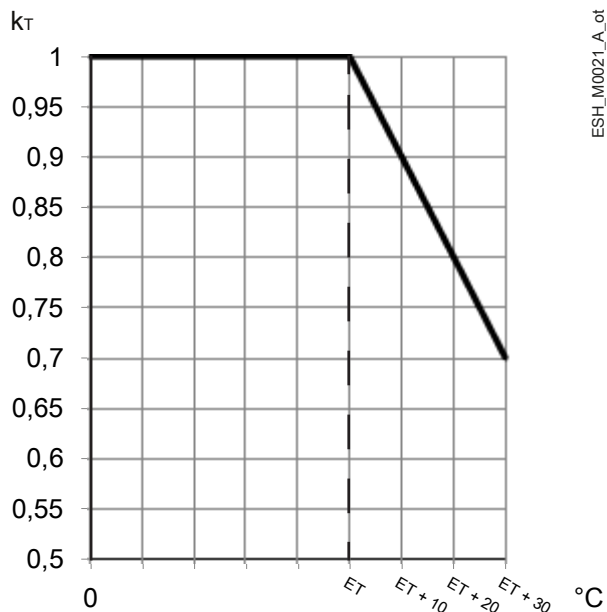

The following diagram shows the downgrading coefficients k_A according to altitude.

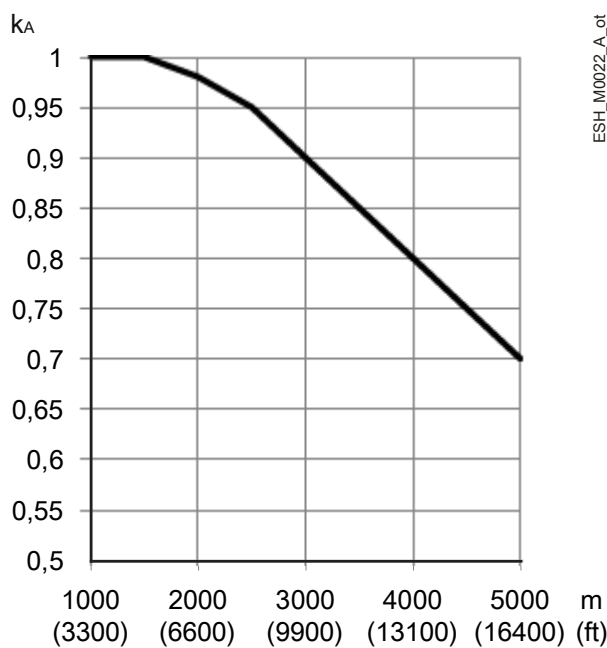

$$P_{max} = P_n \times k_T \times k_A$$

Data	Description
P_{max}	Max. power output
P_n	Rated output
k_T	Downgrading coefficient according to the ambient temperature
k_A	Downgrading coefficient according to the altitude

8.2 Liquid temperature and maximum operating pressure

The diagram shows the maximum operating pressure based on unit model and temperature of pumped liquid.

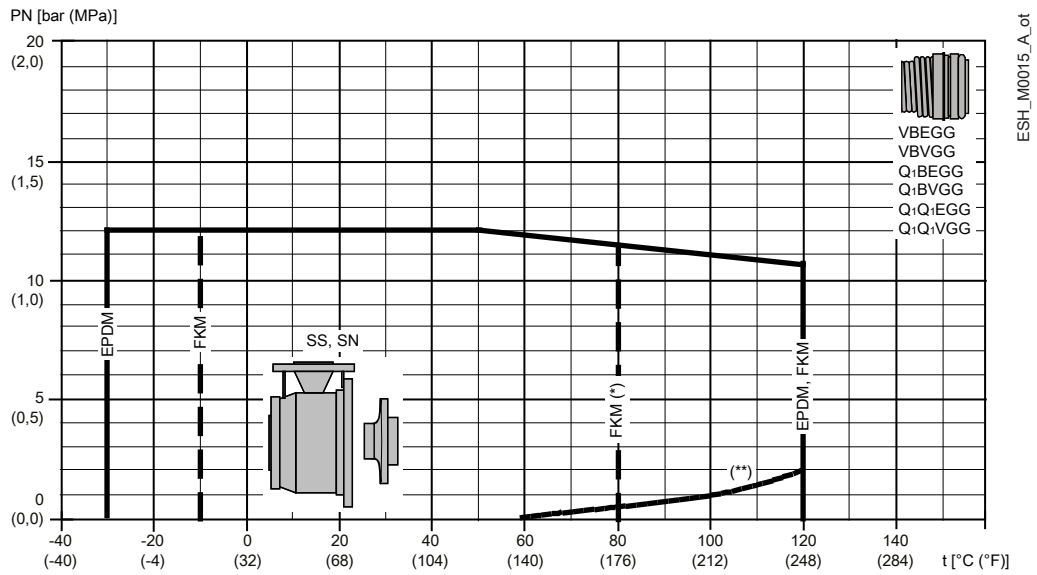

(*) Hot water

(**) Minimum pressure required on the mechanical seal with hot water: it may be different with other liquids

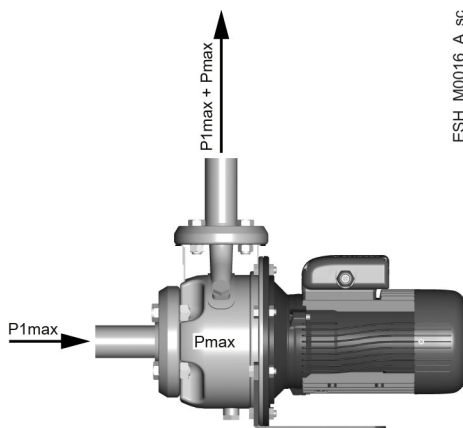

$$P_{1\max} + P_{\max} \leq PN$$

Data	Description
$P_{1\max}$	Maximum input pressure
P_{\max}	Maximum pressure generated by the unit
PN	Maximum operating pressure

NOTE: The formula applies to units with motor with axially locked bearing on the drive side (standard Xylem).

8.3 Maximum head

The tables show the maximum pressure head H according to the model.

50 Hz @2900 min⁻¹ motors

Model	P, kW	H,		Model	P, kW	H,	
		m	ft			m	ft
25-125	0.75	16	53	50-125	2.2	17.5	57
25-125	1.1	21	68	50-125	3	20.6	68
25-160	1.5	24	80	50-125	4	24.8	81
25-160	2.2	31	100	50-160	5.5	33.8	111
25-200	3	39	127	50-160	7.5	40.7	134
25-200	4	48	159	50-200	9.2	52.9	174
25-250	5.5	53	174	50-200	11	59.7	196
25-250	7.5	67	218	50-250	15	70.2	230
25-250	11	82	270	50-250	18.5	79.9	262
32-125	0.75	16	52	50-250	22	88.9	292
32-125	1.1	21	68	65-160	4	19.1	63
32-160	1.5	25	81	65-160	5.5	24.6	81
32-160	2.2	31	101	65-160	7.5	30.7	101
32-200	3	39	129	65-160	9.2	35.7	117
32-200	4	49	161	65-160	11	41.6	136
32-250	5.5	53	174	65-200	15	52.4	172
32-250	7.5	67	218	65-200	18.5	59.3	195
32-250	11	82	269	65-200	22	65.4	215
40-125	1.1	16	52	65-250	30	83.7	275
40-125	1.5	20	65	65-250	37	96.5	317
40-125	2.2	23	77	80-160	11	33	108
40-160	3	31	101	80-160	15	39.5	130
40-160	4	38	124	80-160	18.5	46.4	152
40-200	5.5	49	161	80-200	22	51.8	170
40-200	7.5	58	191	80-200	30	62.3	204
40-250	9.2	65	213	80-200	37	69.8	229
40-250	11	75	245	80-250	45	82.2	270
40-250	15	75	245	80-250	55	93.9	308
40-250	15	88	288	80-250	75	109.6	360

50 Hz @1450 min⁻¹ motors

Model	P, kW	H,		Model	P, kW	H,	
		m	ft			m	ft
P4 25-125 A	0.25	4	13	P4 50-125	0.37	5	16
P4 25-125	0.25	5.2	16	P4 50-125	0.55	6	20
P4 25-160 A	0.25	5.9	20	P4 50-160	0.75	8	27
P4 25-160	0.25	7.4	23	P4 50-160	1.1	10	32
P4 25-200	0.37	9.4	26	P4 50-200	1.1	13	42
P4 25-200	0.55	12	30	P4 50-200	1.5	15	48
P4 25-250	0.75	13	33	P4 50-250 A	2.2	17	57

P4 25-250	1.1	16.4	36	P4 50-250	2.2	19	64
P4 25-250	1.5	20.4	39	P4 50-250	3	22	72
P4 32-125 A	0.25	4.1	43	P4 65-160	0.55	5	15
P4 32-125	0.25	5.2	46	P4 65-160	0.75	6	20
P4 32-160 A	0.25	6	49	P4 65-160 A	1.1	8	25
P4 32-160	0.25	7.5	52	P4 65-160	1.1	9	29
P4 32-200	0.37	9.4	56	P4 65-160	1.5	10	34
P4 32-200	0.55	12	59	P4 65-200	1.5	12	40
P4 32-250	0.75	13.1	62	P4 65-200	2.2	15	48
P4 32-250	1.1	16.4	66	P4 65-200	3	17	56
P4 32-250	1.5	20.4	69	P4 65-250	4	20	67
P4 40-125 A	0.25	4.9	72	P4 65-250	5.5	24	78
P4 40-125	0.25	5.7	75	P4 80-160	1.5	8	26
P4 40-160	0.37	7.4	79	P4 80-160 A	2.2	9	31
P4 40-160	0.55	9.2	82	P4 80-160	2.2	11	35
P4 40-200	0.75	11.9	85	P4 80-200	3	12	40
P4 40-200	1.1	14.2	89	P4 80-200	4	15	51
P4 40-250	1.1	15.6	92	P4 80-250	5.5	20	67
P4 40-250	1.5	18.1	95	P4 80-250	7.5	23	76
P4 40-250	2.2	21.5	98	P4 80-250	11	27	87
P4 50-125	0.25	4.2	102	-	-	-	-

60 Hz @3500 min⁻¹ motors

Model	P, kW	H,		Model	P, kW	H,	
		m	ft			m	ft
25-125	1.1	20	64	40-250	15	87	285
25-125	1.5	20	64	50-125	3	21	67
25-160	1.5	26	85	50-125	4	26	84
25-160	2.2	33	108	50-160	5.5	33	107
25-200	3	41	133	50-160	7.5	40	132
25-200	4	48	158	50-200	9.2	49	162
25-250	5.5	59	192	50-200	11	52	171
25-250	7.5	70	229	50-250	15	69	225
25-250	9.2	80	262	50-250	18.5	78	256
25-250	11	91	297	50-250	22	88	287
32-125	1.1	20	64	65-160	5.5	26	87
32-160	1.5	26	85	65-160	7.5	31	102
32-160	2.2	33	109	65-160	9.2	36	118
32-200	3	41	135	65-160	11	41	133
32-200	4	50	162	65-200	15	52	169
32-250	5.5	59	193	65-200	18.5	60	198
32-250	7.5	70	230	65-200	22	67	221
32-250	9.2	80	263	65-250	30	84	274
32-250	11	91	297	65-250	37	96	313
40-125	1.5	19	61	80-160	15	37	120
40-125	2.2	23	76	80-160	18.5	43	142

40-160	3	32	104	80-200	22	50	163
40-160	4	36	119	80-200	30	64	208
40-200	5.5	44	143	80-200	37	71	231
40-200	7.5	58	191	80-250	45	79	260
40-250	9.2	64	211	80-250	55	92	302
40-250	11	73	238	80-250	75	117	385

60 Hz @1750 min⁻¹ motors

Model	P, kW	H,		Model	P, kW	H,	
		m	ft			m	ft
P4 25-125	0.25	7	24	P4 50-125	0.37	5	16
P4 25-160	0.25	8	26	P4 50-125	0.55	6	21
P4 25-160	0.37	10	32	P4 50-160	0.75	9	29
P4 25-200	0.37	10	32	P4 50-160	1.1	10	34
P4 25-200	0.55	14	45	P4 50-200	1.1	12	40
P4 25-250	0.75	14	47	P4 50-200	1.5	15	48
P4 25-250	1.1	19	61	P4 50-250 A	2.2	21	69
P4 25-250	1.5	23	74	P4 50-250	2.2	17	57
P4 32-125	0.25	7	24	P4 50-250	3	25	82
P4 32-160	0.25	8	26	P4 65-160	0.75	7	22
P4 32-160	0.37	10	32	P4 65-160 A	1.1	8	26
P4 32-200	0.37	10	33	P4 65-160	1.1	9	29
P4 32-200	0.55	14	45	P4 65-160	1.5	10	33
P4 32-250	0.75	14	47	P4 65-200	1.5	13	44
P4 32-250	1.1	19	62	P4 65-200	2.2	16	52
P4 32-250	1.5	23	74	P4 65-200	3	19	62
P4 40-125	0.25	6	18	P4 65-250	4	23	75
P4 40-125	0.37	8	25	P4 65-250	5.5	28	91
P4 40-160	0.37	8	25	P4 80-160 A	2.2	11	36
P4 40-160	0.55	9	30	P4 80-160	2.2	12	38
P4 40-200	0.75	11	36	P4 80-200	3	15	49
P4 40-200	1.1	15	48	P4 80-200	4	17	56
P4 40-250	1.1	16	51	P4 80-250	5.5	21	68
P4 40-250	1.5	18	60	P4 80-250	7.5	27	89
P4 40-250	2.2	23	76	P4 80-250	11	32	106

8.4 Maximum number of starts per hour

Motor power, kW	Starts / h
0.25 - 3	60
4 - 7.5	40
11 - 15	30
18.5 - 22	24
30 - 37	16
45 - 75	8
90 - 160	4

NOTICE:

If a motor other than the one supplied with the pump unit is used, check the maximum number of starts shown in the motor manual.

8.5 Protection class

IP 55.

8.6 Electrical specifications

See the motor data plate.

Permitted tolerances for the supply voltage

Frequency Hz	Phase ~	No. of conductors + earth	UN, V ± %
50	1	2 - 1	220-240 ± 6
	3	3 - 1	230/400 ± 10, 400/690 ± 10
60	1	2 - 1	220-230 ± 6
	3	3 - 1	220/380 ± 5, 380/660 ± 10

8.7 Sound pressure

Measured in free field at a distance of one metre from the unit, with standard motor operating without load.

50 Hz, 2-pole, @2900 min⁻¹ motors

≤ 70 dB except:

Model	LpA, dB ± 2
50-250/150, 65-200/150, 80-160/150, 40-250/150	71
50-250/185, 65-200/185	71.5
50-250/220, 80-160/185, 65-200/220, 80-200/220	72
65-250/300, 80-200/300	74
65-250/370, 80-200/370	74.5

50 Hz, 4-pole, @1450 min⁻¹ motors

≤ 70 dB.

8.8 Materials in contact with the liquid

Identification code	Pump body	Impeller
SS	Pressed stainless steel 1.4404 (AISI 316L)	Pressed stainless steel 1.4404 (AISI 316L)
SN	Pressed stainless steel 1.4404 (AISI 316L)	Cast stainless steel 1.4408 (cast AISI 316)

8.9 Mechanical seal

Unbalanced single acc. EN 12756, version K.

9 Disposal

9.1 Precautions



WARNING:

The unit must be disposed of through approved companies specialised in the identification of different types of materials (steel, copper, plastic, etc.).



WARNING:

It is prohibited to dispose of lubricating fluids and other hazardous substances in the environment.

9.2 WEEE (EU/EEA)

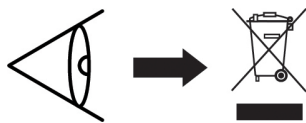

INFORMATION TO USERS pursuant to art. 14 of the Directive 2012/19/EU of the European Parliament and of the Council of 4 July 2012 on waste electrical and electronic equipment (WEEE). The crossed bin symbol on the appliance or on its packaging indicates that the product at the end of its useful life must be collected separately and not disposed of together with other mixed urban waste. Appropriate separate collection for the subsequent start-up of the disused equipment for recycling, treatment and environmentally compatible disposal helps to avoid possible negative effects on the environment and on health and favours the re-use and / or recycling of the materials of which the equipment is composed.

WEEE from users other than private households (classification according to product type, use and current local laws): the separate collection of this equipment at the end of its life is organized and managed by the producer (producer of EEE as per Directive 2012/19/EU). The user who wants to get rid of this equipment can then contact the producer and follow the system that it has adopted to allow the separate collection of equipment at the end of life or select an organization independently authorized to manage waste.

9.3 WEEE (UK)

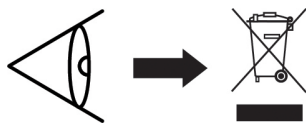

INFORMATION TO USERS pursuant to art. 44 of the The Waste Electrical and Electronic Equipment Regulations 2013 (S. I. 2013 No. 3113). The crossed bin symbol on the appliance or on its packaging indicates that the product at the end of its useful life must be collected separately and not disposed of together with other mixed urban waste. Appropriate separate collection for the subsequent start-up of the disused equipment for recycling, treatment and environmentally compatible disposal helps to avoid possible negative effects on the environment and on health and favours the re-use and / or recycling of the materials of which the equipment is composed.

WEEE from users other than private households (classification according to product type, use and current local laws): the separate collection of this equipment at the end of its life is organized and managed by the producer (producer of EEE as per WEEE Regulations 2013). The user who wants to get rid of this equipment can then contact the producer and follow the system that it has adopted to allow the separate collection of equipment at the end of life or select an organization independently authorized to manage waste.

10 Declarations

Refer to the specific declaration relating to the marking on the product.

10.1 Pump unit (electric pump)



EC Declaration of Conformity (Original)

Xylem Service Italia S.r.l., with headquarters in Via Vittorio Lombardi 14 - 36075 Montecchio Maggiore VI - Italy, hereby declares that the product:

ESHE... or ESHS... electric pump (see label on the last page of 'Safety and Other Information' manual)

fulfils the relevant provisions of the following European Directives:

- Machinery 2006/42/EC and subsequent amendments (ANNEX II - natural or legal person authorised to compile the technical file: Xylem Service Italia S.r.l.).
- Eco-design 2009/125/EC and subsequent amendments, Regulation (EU) 2019/1781 and subsequent amendments (electric motor, if IE2 or IE3 or IE4 marked), Regulation (EU) No 547/2012 and subsequent amendments (water pump, if MEI marked)

and the technical standards:

- EN 809:1998+A1:2009, EN 60204-1:2018.
- EN 60034-30:2009, EN 60034-30-1:2014, EN 60034-2-1:2007, EN 60034-2-1:2014, EN 16480:2021.

Montecchio Maggiore, 28.08.2024

Peter Björnsson
Managing Director

rev.00

EU Declaration of Conformity (No 02)

1. EMCD - Apparatus/Product model: ESHE... or ESHS... (see the label on the last page of "Safety and Other Information" manual)
RoHS - Unique identification of the EEE: ESHE... or ESHS
2. Name and address of the manufacturer:
Xylem Service Italia S.r.l.
Via Vittorio Lombardi 14
36075 Montecchio Maggiore VI
Italy
3. This declaration of conformity is issued under the sole responsibility of the manufacturer.
4. Object of the declaration: electric pump
5. The object of the declaration described above is in conformity with the relevant Union harmonization legislation:
 - Directive 2014/30/EU of 26 February 2014 and subsequent amendments (electromagnetic compatibility)
 - Directive 2011/65/EU of 8 June 2011 and subsequent amendments, including directive (EU) 2015/863 (restriction of the use of certain hazardous substances in electrical and electronic equipment)
6. References to the relevant harmonised standards used or references to the other technical specifications, in relation to which conformity is declared:
 - EN 61000-3-3:2013+A1:2019+A2:2021, EN 61000-3-12:2011, EN 61000-6-2:2005, EN IEC 61000-6-2:2019, EN 61000-6-4:2007 +A1:2011, EN IEC 61000-6-4:2019.

- EN IEC 63000:2018.
7. Notified body: -
8. Additional information:
RoHS - Annex III - Applications exempted from the restrictions: lead as a binding element in steel, aluminium and copper alloys [6(a), 6(b), 6(c)].

Optimize: refer to documentation supplied with the monitoring device [Radio equipment 2014/53/EU and subsequent amendments, Restriction of the use of certain hazardous substances in electrical and electronic equipment 2011/65/EU and subsequent amendments, including the (EU) 2015/863 Directive].

Signed for and on behalf of: Xylem Service Italia S.r.l.

Montecchio Maggiore, 28.08.2024

Peter Björnsson
Managing Director

rev.00



Goulds is a registered trademark of Goulds Pumps, Inc., and is used under license.

Optimize is a trademark of Xylem Inc. or one of its subsidiaries.

10.2 Pump unit (electric pump)

**UK
CA**

UK Declaration of Conformity (original)

Xylem Service Italia S.r.l., with headquarters in Via Vittorio Lombardi 14 - 36075 Montecchio Maggiore VI - Italy, hereby declares that the product

ESHE... or ESHS ... electric pump (see label on the last page of 'Safety and Other Information' manual)

fulfils the relevant provisions of the following UK legal acts

- S.I. 2008/1597 - Supply of Machinery (Safety) Regulations 2008 and subsequent amendments (Schedule 2 - Part 2 - Annex II - natural or legal person authorised to compile the technical file: Xylem Service Italia S.r.l.)
- S.I. 2021/745 - The Ecodesign for Energy-Related Products and Energy Information Regulations 2021 and subsequent amendments (electric motor, if IE2 or IE3 or IE4 marked), S.I. 2019/539 - The Ecodesign for Energy-Related Products and Energy Information (Amendment) (EU Exit) Regulations 2019 (water pump if MEI marked)

and technical standards

- EN 809:1998+A1:2009, EN 60204-1:2018.
- EN 60034-30:2009, EN 60034-30-1:2014, EN 60034-2-1:2007, EN 60034-2-1:2014, EN 16480:2021.

Montecchio Maggiore, 28.08.2024

Peter Björnsson
Managing Director

rev.00



UK Declaration of Conformity (No 02)

1. EMCD - Apparatus/Product model: ESHE... or ESHS ... (see label on the last page of 'Safety and Other Information' manual)
RoHS - Unique identification of the EEE: ESHE or ESHS.
2. Name and address of the manufacturer:
Xylem Service Italia S.r.l.
Via Vittorio Lombardi 14
36075 Montecchio Maggiore VI
Italy.
3. This declaration of conformity is issued under the sole responsibility of the manufacturer.
4. Object of the declaration: electric pump
5. The object of the declaration described above is in conformity with the relevant UK legislative acts:
 - S.I. 2016/1091 - The Electromagnetic Compatibility Regulations 2016 and subsequent amendments.
 - S.I. 2012/3032 - The Restriction of the Use of Certain Hazardous Substances in Electrical and Electronic Equipment Regulations 2012 and subsequent amendments.
6. References to the relevant designated standards used or references to the other technical specifications, in relation to which conformity is declared:
 - EN 61000-3-3:2013+A1:2019+A2:2021, EN 61000-3-12:2011, EN 61000-6-2:2005, EN IEC 61000-6-2:2019, EN 61000-6-4:2007 +A1:2011, EN IEC 61000-6-4:2019.
 - EN IEC 63000:2018.
7. Approved body: - - -
8. Additional information:
RoHS - S.I. 2020/1647 - The Hazardous Substances and Packaging (Legislative Functions and Amendment) (EU Exit) Regulations 2020 - regulation 3(1), Schedule A2, Table 1 - Exempted applications from the restrictions: lead as a binding element in steel, aluminium and copper alloys [12, 15, 18].

Optimize: refer to documentation supplied with the monitoring device [S.I. 2017/1206 - The Radio Equipment Regulations 2017 and subsequent amendments, S.I. 2012/3032 - The Restriction of the Use of Certain Hazardous Substances in Electrical and Electronic Equipment Regulations 2012 and subsequent amendments].

Signed for and on behalf of: Xylem Service Italia S.r.l.

Montecchio Maggiore, 28.08.2024

Peter Björnsson
Managing Director

rev.00



Goulds is a registered trademark of Goulds Pumps, Inc., and is used under license.

Optimize is a trademark of Xylem Inc. or one of its subsidiaries.

11 Warranty

11.1 Information

For information on the warranty refer to the documentation of the sale contract.

Xylem |'zīləm|

- 1) The tissue in plants that brings water upward from the roots;
- 2) A leading global water technology company.

We're a global team unified in a common purpose: creating innovative solutions to meet our world's water needs. Developing new technologies that will improve the way water is used, conserved, and re-used in the future is central to our work. We move, treat, analyze, and return water to the environment, and we help people use water efficiently, in their homes, buildings, factories and farms. In more than 150 countries, we have strong, long-standing relationships with customers who know us for our powerful combination of leading product brands and applications expertise, backed by a legacy of innovation.

For more information on how Xylem can help you, go to www.xylem.com



Xylem Service Italia S.r.l.
Via Vittorio Lombardi 14
36075 - Montecchio Maggiore (VI) - Italy

Goulds is a registered trademark of Goulds Pumps, Inc. and is used under license.

© 2020 Xylem, Inc. Cod.001080186GEN rev.B ed.10/2024