

GST05/10 Sub-Prime® Electric Submersible Trash Pumps

The GST Sub-Prime line is a selection of portable, electric submersible pumps designed for trash-laden applications. Standard side discharge and semi-vortex cast iron impeller enable these units to handle solids up to 1 in. (25mm) in diameter. The fully removable volute makes clean-out fast and easy. The GST Sub-Prime line offers flow rates to 75 gpm (4.75 l/sec) and maximum heads to 48 feet (14.6 m). Units are available in 0.5 hp / 0.4 kW (GST05) and 1 hp / 0.75 kW (GST10) models. High performance and affordability combine to make the GST Sub-Prime pump ideal for use in general dewatering applications, as well. For automatic starting applications, a piggy-back single float switch can be supplied.



Features and Benefits

- CSA listed and approved
- Solids handling up to 1 in. (25mm) in diameter
- Dry-running capability without damage
- No control panel required
- Portable, lightweight, durable
- Side discharge design
- Non-wicking cable with strain relief
- High-torque, capacitor-start motor
- Motor thermal overload protection
- Silicon Carbide upper and lower mechanical seal
- Triple sealed – internal upper and lower mechanical seals and external lip seal
- Semi-vortex cast iron impeller
- Cast iron volute, fully removable for easy clean-out

Specification

	GST05	GST10
HP (kW)	0.5 (0.4)	1.0 (.75)
Max. Flow - gpm (l/sec)	60 (3.8)	75 (4.7)
Max. Head - ft (m)	33 (10)	48 (14.6)
Max. Solids - in. (mm)	1 (25)	1 (25)
Cable Length - ft (m)	30 (9)	50 (15)
Discharge - in. (mm)	2 (50)	2 (50)
RPM	3600	3600
Max. Fluid Temp.	90° F (32° C)	90° F (32° C)
PH Range	6.5-8.0	6.5-8.0
Voltage	115, 230	115, 230
Amps	5.8, 2.9	10.3, 5.1
Phase	Single	Single
Height - in. (mm)	14.67 (373)	16.36 (416)
Width - in. (mm)	9.85 (250)	9.85 (250)
Weight - lbs. (kg)	22 (10)	29 (13)
Max. Sub. - ft (m)	16.5 (5)	16.5 (5)

GST Sub-Prime® Performance Curves

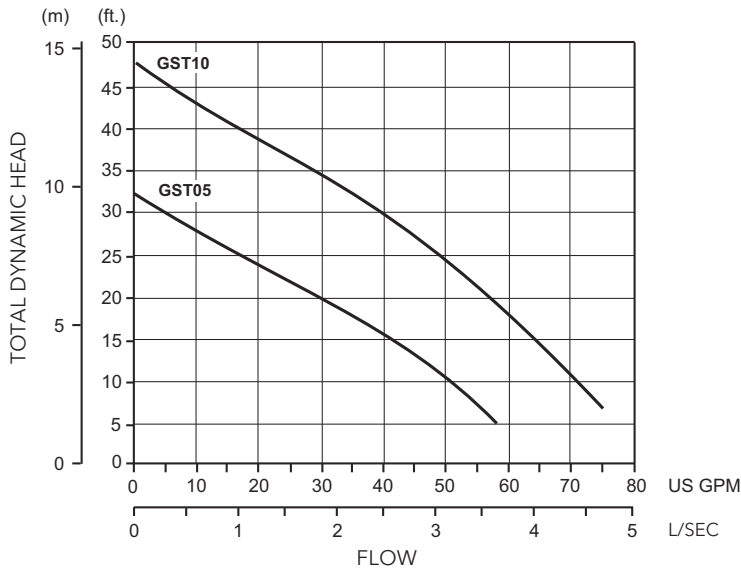

WARNING: Pumps are not designed for use in explosive atmosphere, flammable environments or for pumping volatile liquids.

Design & Construction

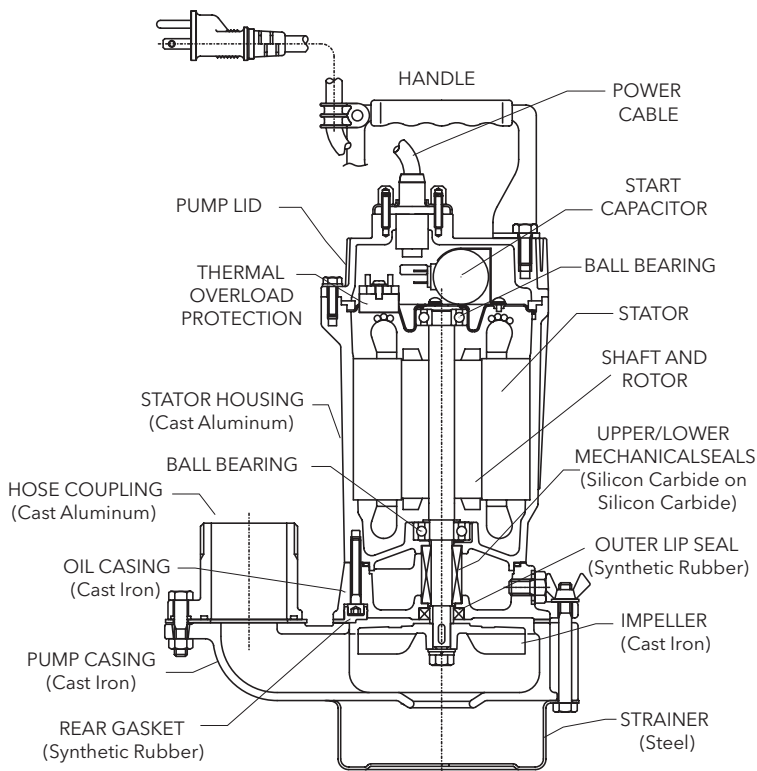

Float Switch

Optional Float Switches available for automatic, remote activation of Sub-Prime pumps. Package consists of 30 ft/50ft (9m/15m) power cord with piggy-back power plug, variable length float tether, and sealed float. Typical configuration shown below.

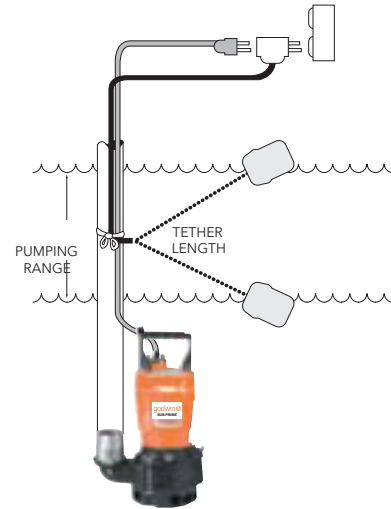

Pumping range determined by tether length according to the following guide.

Tether Length	3.5	5	7	9	11	13	15	in.
	89	127	178	229	279	330	381	mm
Pumping Range	6.5	7.5	8.5	10	11	12.5	13.5	in.
	165	191	216	254	279	318	343	mm

Pumping range based on operation in non-turbulent conditions. Actual range may vary due to temperature conditions and cord shape. Tether length increases variance of pumping range.

Dimensions

