

NC150 Dri-Prime® Pump

WITH FINAL TIER 4 DIESEL ENGINE

The Godwin Dri-Prime NC150 pump is an extremely powerful yet compact pump with flow capabilities to 1770 USGPM.

The NC150 features the unique patented Flygt N-technology with its innovative self-cleaning impeller and is able to automatically prime to 28' of suction lift from dry.

NC Series pumps are engineered to deliver sustained high efficiency resulting in lower energy and fuel costs while reducing unplanned downtime.

This makes the NC150 a best-in-class portable pump suitable for both sewage and clean water applications.



Features and Benefits

- Dri-Prime (continuously operated Venturi air ejector priming device) requiring no periodic adjustment. Optional compressor clutch available.
- Incorporates N-technology for non-clog performance, sustained high efficiency and long-term energy/fuel savings.
- Hard-Iron™ (EN12513:2000) impeller and insert ring.
- Dry-running, high-pressure oil bath mechanical seal with highly abrasion resistant silicon carbide faces.
- Close-coupled centrifugal pump mounted to a diesel engine or electric motor for easy pump/engine/motor changeover in the field.
- Also available in a critically silenced unit that reduces noise levels to less than 70 dBA at 30'.
- Standard engine JCB TCAE-55 (FT4) EPA emissions compliant diesel engine. Also available with John Deere 4045TFC03 (FT4).

Specifications

| | |
|-----------------------|--------------------|
| Suction connection | 6" 150# ANSI B16.5 |
| Delivery connection | 6" 150# ANSI B16.5 |
| Max capacity | 1770 USGPM † |
| Max Impeller diameter | 11.3" |
| Max operating temp | 176°F* |
| Max working pressure | 87 psi |
| Max suction pressure | 58 psi |
| Max casing pressure | 131 psi |
| Max operating speed | 2200 rpm |

* Please contact our office for applications in excess of 176°F.

† Larger diameter pipes may be required for maximum flows.

Performance Curve

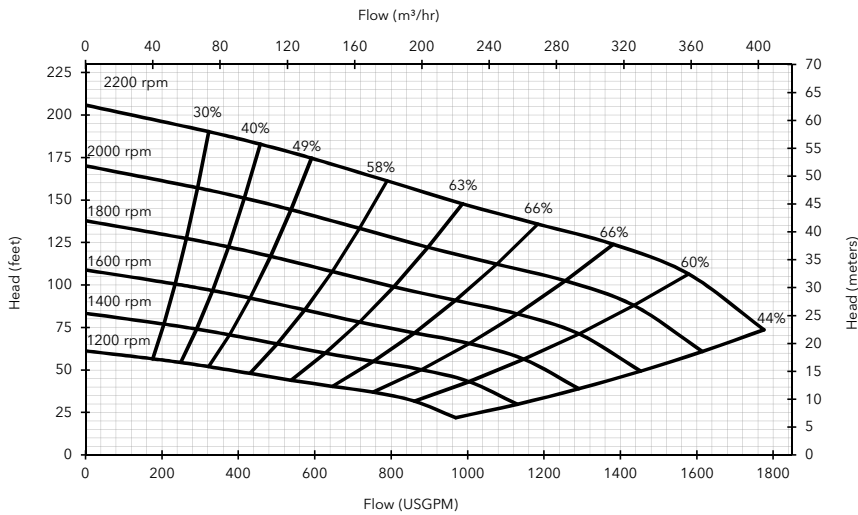

Engine option 1

JCB, TCAE-55 (FT4), 74 HP @ 2200 rpm

Impeller diameter 11.3"

Pump speed 2200 rpm

Suction Lift Table

| Total Suction Head (feet) | Total Delivery Head (feet) | | | | |
|---------------------------|----------------------------|-----|-----|-----|-----|
| | 66 | 117 | 153 | 169 | 189 |
| | Output (USGPM) | | | | |
| 10 | 1173 | 902 | 433 | 271 | 36 |
| 15 | 974 | 830 | 397 | 180 | - |
| 20 | 812 | 722 | 253 | - | - |
| 25 | 632 | 505 | 180 | - | - |

Fuel capacity: 60 US Gal

Max Fuel consumption @ 2200 rpm: 4.2 US Gal/hr

Max Fuel consumption @ 1800 rpm: 2.2 US Gal/hr

Weight (Dry): 3,270 lbs

Weight (Wet): 3,700 lbs

Dimensions: (L) 119" x (W) 66" x (H) 77"

Performance data provided in tables is based on water tests at sea level and 20°C ambient. All information is approximate and for general guidance only. Please contact the factory or office for further details.

Materials

| | |
|-----------------------------|--|
| Pump casing & suction cover | Cast iron BS1561:1997 |
| Wearplates | Front - Hard Iron EN12513:2000 Rear - Cast Iron BS1561:1997 0 |
| Pump Shaft | Carbon steel BS970:1991 817M40T |
| Impeller | Hard Iron EN12513:2000 |
| Non-return Valve body | Cast iron BS1561:1997 |
| Mechanical Seal | Silicon carbide face; Viton elastomers; Stainless steel body |

Engine option 2

John Deere, 4045TFC03 (FT4), 74 HP @ 2200 rpm

Impeller diameter 11.3"

Pump speed 2200 rpm

Suction Lift Table

| Total Suction Head (feet) | Total Delivery Head (feet) | | | | |
|---------------------------|----------------------------|-----|-----|-----|-----|
| | 66 | 117 | 153 | 169 | 189 |
| | Output (USGPM) | | | | |
| 10 | 1173 | 902 | 433 | 271 | 36 |
| 15 | 974 | 830 | 397 | 180 | - |
| 20 | 812 | 722 | 253 | - | - |
| 25 | 632 | 505 | 180 | - | - |

Fuel capacity: 60 US Gal

Max Fuel consumption @ 2200 rpm: 4.7 US Gal/hr

Max Fuel consumption @ 1800 rpm: 2.4 US Gal/hr

Weight (Dry): 3,250 lbs

Weight (Wet): 3,680 lbs

Dimensions: (L) 119" x (W) 66" x (H) 91"

Performance data provided in tables is based on water tests at sea level and 20°C ambient. All information is approximate and for general guidance only. Please contact the factory or office for further details.

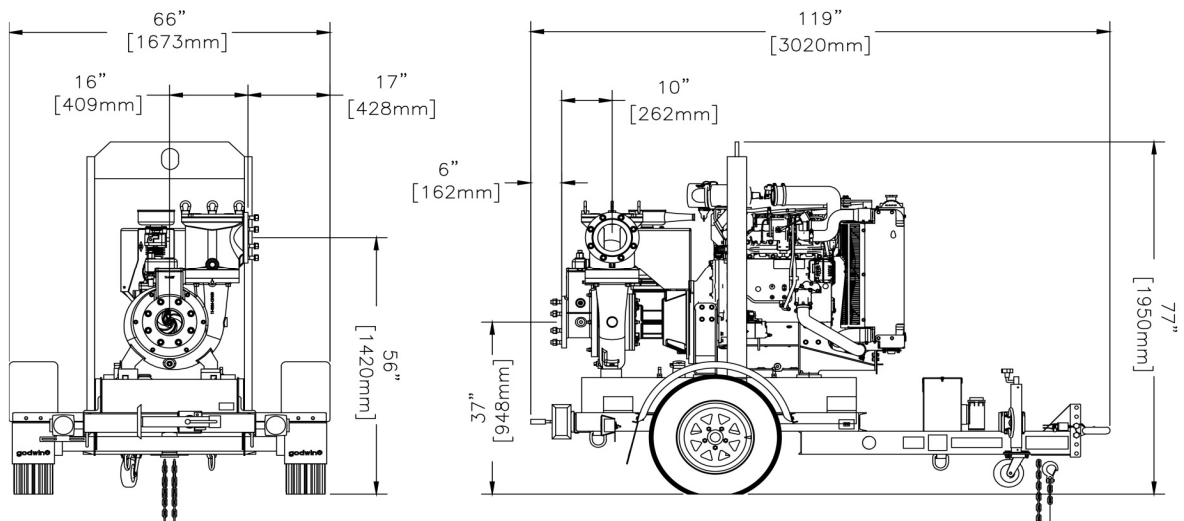

84 Floodgate Road
Bridgeport, NJ 08014 USA
(856) 467-3636 · Fax (856) 467-4841

Reference number : 200GPA0000159
Date of issue : November 3, 2015
Issue : -

www.godwinpumps.com