

MTDPC

(also known as MTPC)

INSTALLATION AND OPERATION MANUAL

MultiTrode Dual Pump Controller

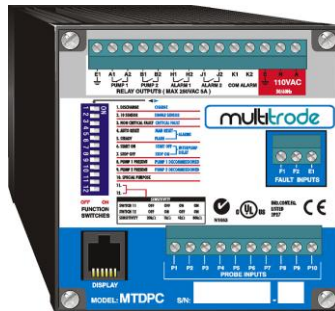
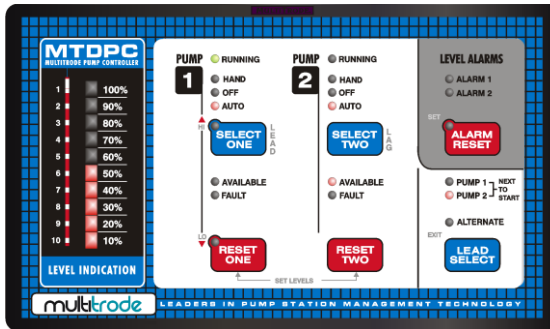

This Manual is the support documentation for the installation, commissioning and operation of the MultiTrode MTDPC.

Document R4
(Last updated 7 August 2013)

MultiTrode is a registered trademark of MultiTrode Pty. Ltd. & MultiTrode Inc. MultiTrode products are protected by patents, patent applications and trademarks in the USA, Canada, Europe, Japan, Australia and other countries. MultiTrode reserves the right to modify performance, specifications or design without notice. This publication is protected by copyright. No part of this publication may be reproduced by any process, electronic or otherwise, without the express written permission of MultiTrode Pty Limited.

Copyright © 2013 MultiTrode Pty Ltd

WARNINGS AND CAUTIONS

IMPORTANT



TO REDUCE THE RISK OF ELECTRIC SHOCK, LEAVE ALL SERVICING TO QUALIFIED AND AUTHORISED TECHNICAL STAFF. THERE ARE NO USER SERVICEABLE PARTS INSIDE.

Information to User

Please read through the manual so you will know how to operate and obtain maximum performance from your product. After you have finished reading the manual, put it away in a safe place for future reference.



WARNING:

Do not use this unit in environments that may contain flammable/explosive or chemically aggressive gases or powders.

Terms Used in this Manual



This symbol is intended to alert the user to the presence of uninsulated “dangerous voltages” within the product’s enclosure.

WARNING

THIS SYMBOL IS USED WHERE NON-COMPLIANCE COULD RESULT IN INJURY OR DEATH.

CAUTION

This symbol is used where non-compliance could result in incorrect operation, damage to, or failure of, the equipment.



This symbol is used to highlight an issue or special case within the body of the manual.

WARNING

TO PREVENT FIRE OR SHOCK HAZARD, DO NOT EXPOSE THIS PRODUCT TO RAIN OR MOISTURE.

WARNING

FOR OPERATION IN AN ATMOSPHERE OF EXPLOSIVE GASES CONTACT MULTITRODE FOR INFORMATION ON INTRINSICALLY SAFE BARRIERS.

CONTENTS

1	Typical Applications	7
2	Installation	8
2.1	Installation Instructions for the MTDPC	8
2.2	Wiring Instructions for the MTDPC	10
2.3	Wiring Diagram	16
3	Overview	17
3.1	Level Indicators	17
3.2	Pump Indicators	17
3.3	Select Buttons	18
3.4	Level Alarm Indicators	18
3.5	Next to Start Indicators	18
3.6	Fault Indicators	18
3.7	Reset Buttons	18
4	Operation	19
4.1	Pump Operation Modes	19
4.2	Analysing Pump Status	21
4.3	Level Alarm Indicators	23
4.4	Duty Pump Alternation (Next To Start)	24
5	Configuration	25
5.1	Configuring Level Devices	25
5.2	Setting Pump Levels	27
5.3	Setting Level Alarms	29
5.4	Critical & Non Critical Fault Selection (Function Switch 3)	30
5.5	Decommissioning Pumps (Function Switches 8 & 9)	31
5.6	Setting the Alternate/Fixed Pump Sequence	31
6	Configuration Quick Start	32
7	Special Features	33
7.1	Simulating Levels for Commissioning Purposes	33
7.2	Automatic Sensor Fault Detection	33
7.3	Interpump Delays	34
7.4	LED Test	34
8	Default Settings	35
8.1	Activation / Deactivation Default Levels	35
8.2	Function Switch Default Settings	36
8.3	Resetting Controller Defaults	36
9	Specifications	37
10	MTDPC Connectors & Dip Switch	38
11	Glossary of Terms	39
12	List of Abbreviations Used	40



Introduction – MultiTrode MTDPC Pump Controller

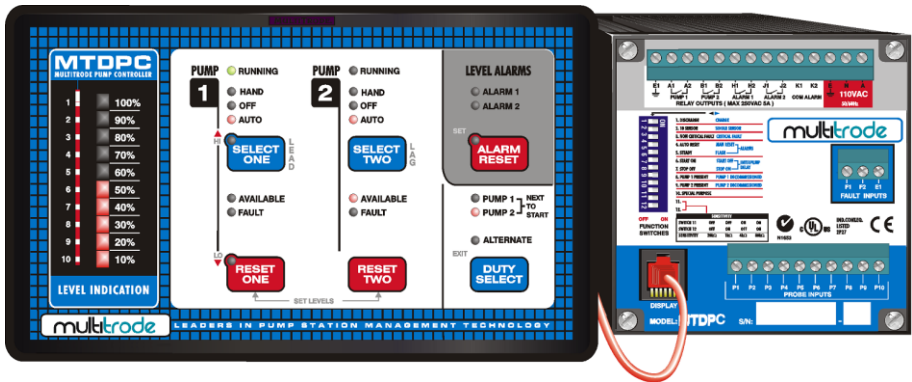

The MTDPC is a cost effective self-contained dual pump controller, designed for simplicity in both installation and operation. Through soft-touch selector buttons and high intensity Light Emitting Diodes (LEDs), the operator is provided with clear, precise indications of liquid level and pump status.

When installed with a MultiTrode probe, the MTDPC offers a variety of high-performance features:

- Two pump, two alarm controller*
- Level indication*
- Charge or discharge operation*
- Pump mode selection*
- Alarm mode selection*
- Delayed or instantaneous pump operation*
- Duty pump selection or alternation*
- Next pump to start indication*
- Hi or Lo level alarm activation*
- Auto or Manual level alarm reset*
- Flashing alarm and fault indicators*
- Sensitivities for a wide range of liquids*
- Fault inputs critical/non-critical*
- Perfect for intrinsically safe application when used with MTISB (USA only)*

The unit has DIN rail mounting, plug-in terminals and a detached keypad, enabling simple installation, especially where available space is limited.

We are sure you will be fully satisfied with our product.

1 Typical Applications

The MultiTrobe Pump Controller is suitable for a multitude of applications

- ❑ The ideal solution for reservoirs, water towers and lift stations.
- ❑ Enables water tanks, sullage pits and storm water control to be fully integrated into building management.
- ❑ MultiTrobe conductive probes are resistant to a wide range of aggressive liquids.
- ❑ Perfect for a wide range of liquids and thick slurries encountered in many applications.
- ❑ Water, ballast and sullage can be reliably controlled by the MultiTrobe Pump Controller.

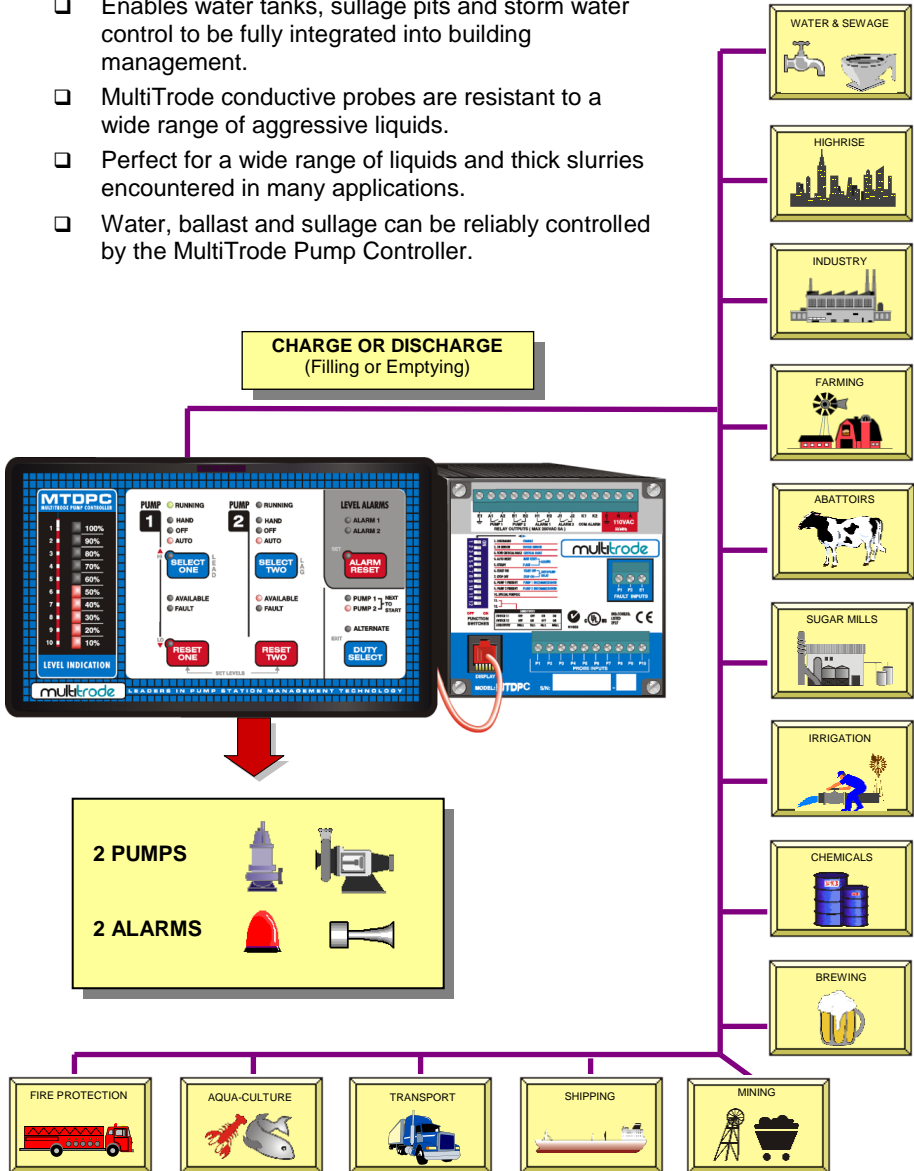

2 Installation

2.1 Installation Instructions for the MTDPC



WARNING:

Do not use this unit in environments that may contain flammable/explosive or chemically aggressive gases or powders.

The following describes the mounting of the MTDPC.

The pump controller housing is mounted on an industry standard (Asymmetric 35 x 7.5mm) DIN Rail. The keypad unit is mounted separately (typically on the switchboard's inner door - escutcheon). The keypad cable is then plugged into the display socket on the controller. This simplifies wiring by eliminating large looms to the door. The following figures illustrate installation suggestions.



To minimise interference it is important that the cable to the MTDPC keypad is not routed with mains cabling.

CAUTION

Cables greater than 3 meters in length do not comply with EMC requirements. Any standard RJ45 cable can be used. However, it is recommended the cable supplied be used where possible.

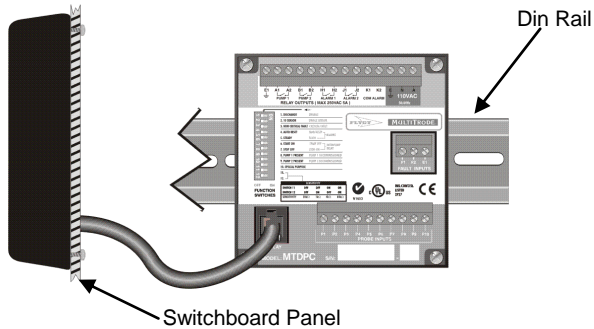

WARNING

For operation in an atmosphere of explosive gases, contact MultiTrove on Intrinsically Safe Barriers (USA only).

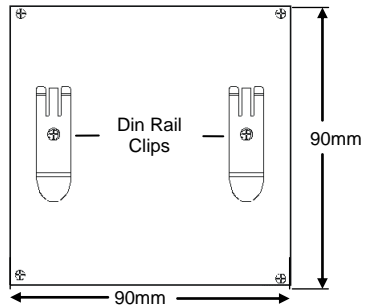
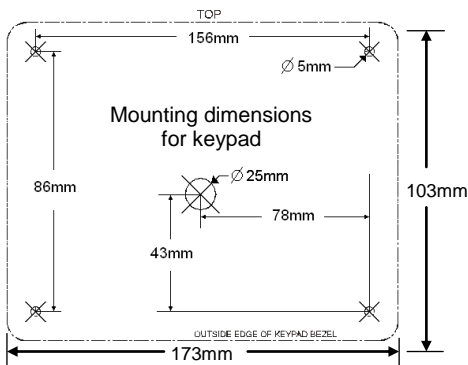

2.2 Wiring Instructions for the MTDPC

General precautions



Electrical Hazard:

- A certified electrician must supervise all electrical work. Comply with all local codes and regulations.
 - Before starting work on the unit, make sure that the unit is isolated from the power supply and cannot be energized.
 - Make sure that all unused conductors are insulated.
 - There is a risk of electrical shock or explosion if the electrical connections are not correctly carried out or if there is fault or damage on the product.
-



WARNING:

Do not use this unit in environments that may contain flammable/explosive or chemically aggressive gases or powders.

Requirements

These general requirements apply for electrical installation:

- The mains voltage and frequency must agree with the specifications for the product.
- Circuit breakers must be installed between the main voltage line and this unit.
- All fuses and circuit breakers must have the proper rating, and comply with local regulations.
- The cables must be in accordance with the local rules and regulations.

Cables

These are the requirements to follow when you install cables:

- The cables must be in good condition, not have any sharp bends, and not be pinched.
- The sheathing must not be damaged and must not have indentations or be embossed (with markings, etc.) at the cable entry.
- The minimum bending radius must not be below the accepted value.

Earthing (Grounding)



Electrical Hazard:

- You must earth (ground) all electrical equipment. This applies to the pump equipment, the driver, and any monitoring equipment. Test the earth (ground) lead to verify that it is connected correctly.
 - If the power cable is jerked loose by mistake, the earth (ground) conductor should be the last conductor to come loose from its terminal. Make sure that the earth (ground) conductor is longer than the phase conductors. This applies to both ends of the power cable.
-

The following section provides a detailed description of how to wire the MTDPC.

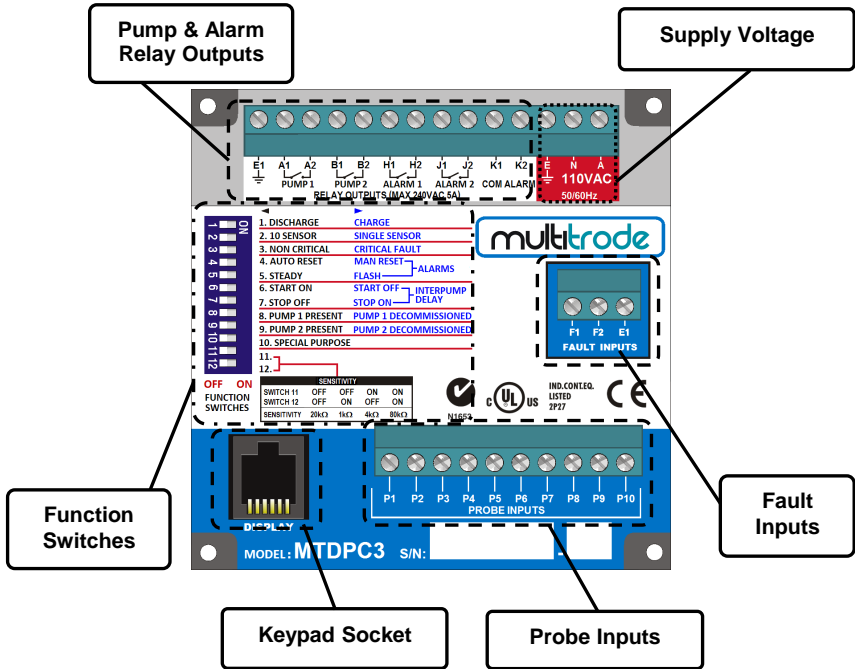

2.2.1 Supply Voltage

The MTDPC is mains powered by either 240VAC (50/60Hz) or 110VAC (50/60Hz) as indicated.

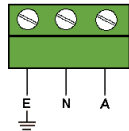

2.2.2 Keypad

A cable is supplied to connect the controller to the keypad.

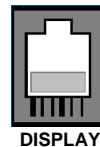

CAUTION Cables greater than 3 meters in length do not comply with EMC requirements. Any standard RJ45 cable can be used. However, it is recommended the cable supplied be used where possible.

2.2.3 Level Devices

There are many types of level sensing devices compatible with the MTDPC. The most common types are listed below.

When using 10-sensor probe devices ensure that 'Function Switch 2' is set to OFF. For **ALL** single sensor devices ensure 'Function Switch 2' is set to ON.

1	ON	1. DISCHARGE	CHARGE
2	ON	2. 10 SENSOR	SINGLE SENSOR
3		3. NON CRITICAL	CRITICAL FAULT
4		4. AUTO RESET	MAN RESET
5		5. STEADY	FLASH
6		6. START ON	START OFF
7		7. STOP OFF	STOP ON
8		8. PUMP 1 PRESENT	PUMP 1 DECOMMISSIONED
9		9. PUMP 2 PRESENT	PUMP 2 DECOMMISSIONED
10		10. SPECIAL PURPOSE	
11		11.	
12		12.	

SENSITIVITY			
SWITCH 11	OFF	OFF	ON
SWITCH 12	OFF	ON	OFF
SENSITIVITY	20kΩ	1kΩ	4kΩ 80kΩ

2.2.3.1 10 Sensor Probe

When using 10-sensor probes, you must configure the MTDPC to operate in 10-sensor mode (Set function switch 2 to OFF).

Wire each cable of the multi-sensor probe into its corresponding probe input terminal. Each wire from the probe is numbered from 1-10. Number one connects to input P1. Number ten connects to P10. When the multi-sensor probe is suspended from its cable, number one is at the top of the probe, number ten is at the bottom of the probe.

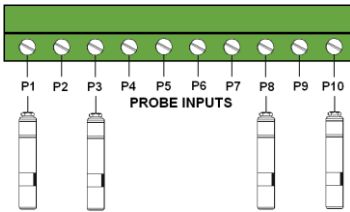
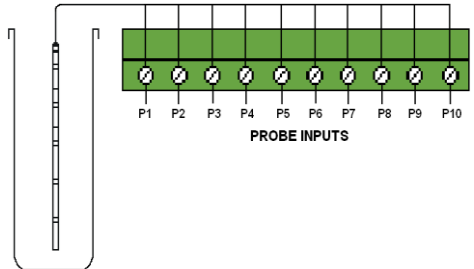

2.2.3.2 Single Sensor Probes

Connect the single sensor probes to the appropriate probe terminals on the MTDPC.

When used with single sensor probes, you must configure the MTDPC to operate in single sensor mode (set function switch 2 to ON). A probe sensor must be connected to each level input where an activation or deactivation level has been set.

2.2.3.3 Ball Float

Wire each ball float into the desired input terminal on the rear of the MTDPC.

When using ball floats, the MTDPC must be set to operate in single sensor mode (Set function switch 2 to ON). A ball float must be connected to each level input that has an activation/deactivation level assigned to it.

Each ball float needs to have the N/O relay contact connected to earth.

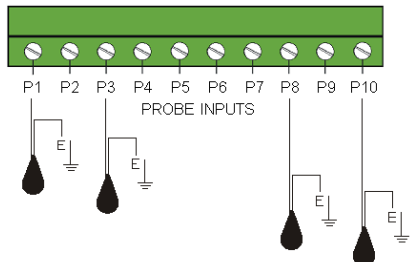

2.2.4 Outputs

This section shows the wiring for the Pump Controller outputs.

CAUTION

To improve product reliability, spark-suppressing circuitry had been included internally across each relay output. It is therefore, important to wire each output as shown.

2.2.4.1 Pump Relays

Connect the Active Line to A1 & B1 contactor coils or start relays (Load line) to outputs A2 & B2

Relays are rated at 250V, 5amp resistive or 2 amp inductive.

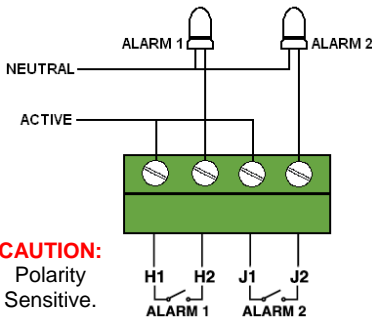

CAUTION:
Polarity Sensitive.

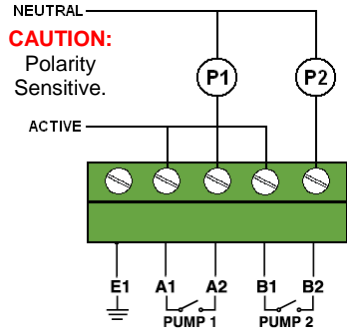

CAUTION:
Polarity Sensitive.

2.2.4.2 Level Alarm Relays

Connect the Alarm Active Line to H1 & J1. Wire the Alarm Load Line to outputs H2 & J2.

2.2.4.3 Common Alarm Relay

The common alarm relay default is set to activate when **ANY** pump fault is unacknowledged.

When an additional alarm is needed, the common alarm relay can be used.

Connect the Alarm Active Line to K1. Wire the Alarm Load Line to outputs K2.

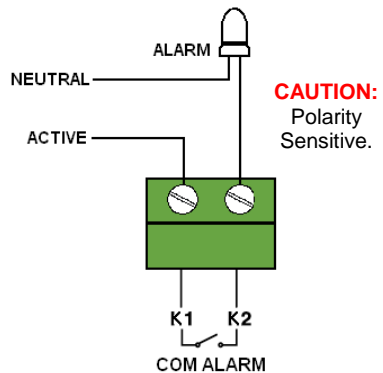

CAUTION:
Polarity Sensitive.

2.2.5 Inputs

To protect a customer's valuable resource, the MultiTrode Dual Pump Controller can be configured to detect:

- Thermal overload conditions
- Seal failures
- Low flow condition

Other fault conditions can be detected where an appropriate switch or relay is incorporated.

Most motors have inbuilt thermal protection. When a motor starts, a lot of heat is generated and if this heat is excessive it may damage the motor windings. Many reasons can be attributed to the excess generation of heat, i.e. aged windings, motor overload, locked rotor, repetitive starts, supply faults and many others.

Pump manufacturers usually provide sensors within the motor housing. If a sensor is connected to an appropriate detection relay, then the MTDPC will be able to switch off the pump in the event of a pump fluid seal failure.

When monitoring flow rate is important, flow rate detector relay outputs can be integrated into the Pump Controller fault detection system. This relay is shown as the fault input switch, illustrated in the diagram below.

Wire the pump fault inputs as per diagram.

The fault circuit activates when the contact closes between the fault-input terminal and the E1 terminal.

You can configure the fault inputs to activate a critical or non-critical fault via 'Function Switch 3'.

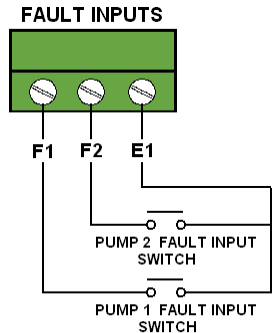

 **BOTH** pump fault inputs (F1 & F2) are set to either non-critical or critical, via 'Function Switch 3' selection.

1	DISCHARGE	CHARGE
2	10 SENSOR	SINGLE SENSOR
3	3. NON CRITICAL	CRITICAL FAULT
4	AUTO RESET	MAN RESET
5	STEADY	FLASH
6	START ON	START OFF
7	STOP OFF	STOP ON
8	PUMP 1 PRESENT	PUMP 1 DECOMMISSIONED
9	PUMP 2 PRESENT	PUMP 2 DECOMMISSIONED
10	SPECIAL PURPOSE	
11		
12		

		SENSITIVITY			
FUNCTION SWITCHES	OFF	ON	OFF	ON	ON
SWITCH 11	OFF	OFF	ON	OFF	ON
SWITCH 12	OFF	ON	OFF	ON	ON
SENSITIVITY	20kΩ	1kΩ	4kΩ	80kΩ	

2.3 Wiring Diagram

MultiTrode Dual Pump Controller (MTDPC) Schematic

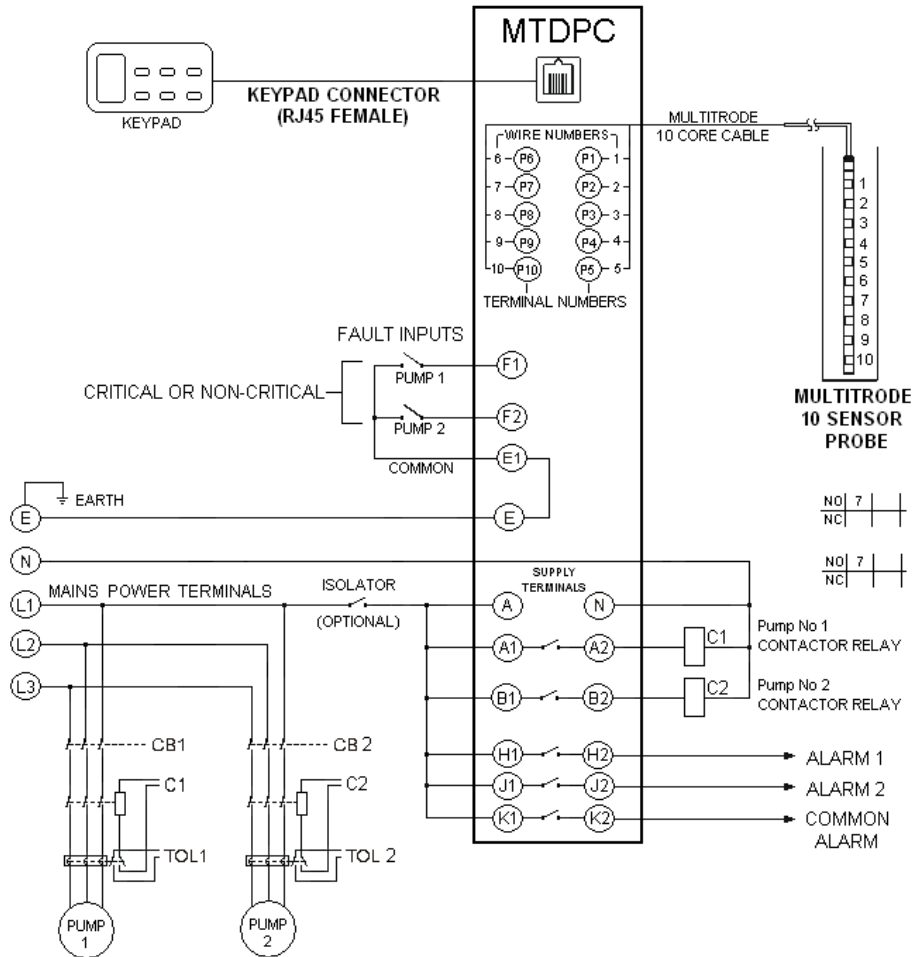

3 Overview

The MultiTrode Dual Pump Controller is an advanced pump control device, which provides control for two pumps and two liquid level alarms. Indication of liquid level, system status, fault conditions and alarms are via high intensity LEDs that remain visible in all light conditions.

This section familiarises you with the look and feel of the pump controller and provides general information on the system components and their functions.

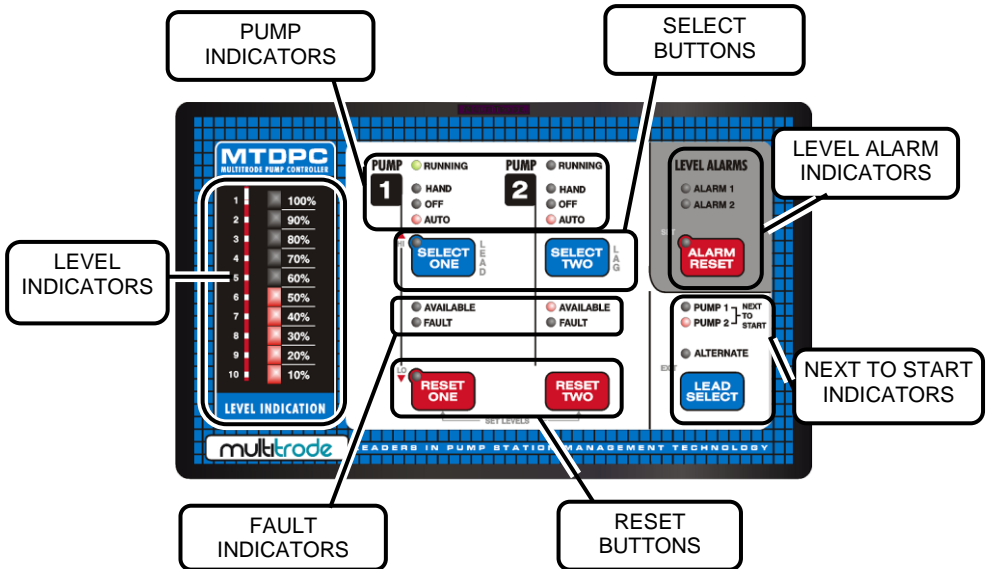

3.1 Level Indicators

The level indicators on the left of the front panel have two basic functions. The first function is to indicate the present level of the liquid. The second function is used for setting level set points during configuration of the controller.

The percentages to the right of the Level Indicators are used to signify the level of the pit or tank in 10% steps. If a particular indicator is flashing, this indicates that the controller has detected a fault with that particular sensor. Although the controller will continue to function, it is recommended that the cause of the fault be identified and the problem rectified.

During configuration of the controller, the level indicators are used to indicate various parameters such as pump and alarm activation/deactivation settings.

3.2 Pump Indicators

The pump indicators are used to denote each pump's operating mode at an installation. When a pump is activated, the corresponding **Running** LED is ON. Each of the two pumps can be set to run in Auto, Off, Manual (Hand) or Manual/Hand Override mode by using the 'Select' button for that pump.

3.3 Select Buttons

A 'Select' button is provided for each pump and is used to cycle a pump through Auto, Off and Manual modes (Pump indicator LEDs indicate the current mode). The 'Select' buttons are also used as function buttons.

When entering a function setting, the **Select One** button corresponds to the duty pump. The **Select Two** button corresponds to the standby pump.

The **Select One** button has the extra function of being used to increase a configuration value. The (HI) LED, which forms part of this button, is used to indicate when the button has assumed this extra function.

3.4 Level Alarm Indicators

The level alarm indicators, **Alarm 1** and **Alarm 2**, activate when an abnormal liquid level condition has been detected. Usually set when liquid levels are either too high or too low.

The **Alarm Reset** button is used to reset unacknowledged alarm faults, select alarms, mute present alarms as well as being used as a set function button. The set function is used to save any changes made while in configuration mode.

3.5 Next to Start Indicators

The **Next to Start** indicators show which pump will start next. If no pump indicators are ON, then all pumps must be either running, decommissioned or unavailable.

When the alternate indicator is ON, the controller is automatically alternating between the two pumps.

The **Duty Select** button is used to scroll through pump 1, pump 2 and alternate pump selection modes as well as an exit button (used to discard any changes made while programming the controller).

3.6 Fault Indicators

The pump fault indicators are used to denote pump availability and current fault conditions. Faults have three states; present, unacknowledged and cleared.

3.7 Reset Buttons

These buttons are used to reset unacknowledged pump faults as well as being used for function buttons.

The **Reset One** button has the extra function of being used to decrease a configuration value. The (LO) LED, which forms part of this button, is used to indicate when the button has assumed this extra function.

4 Operation

The MultiTrobe pump controller's main function is to automatically provide liquid level control by activating and deactivating pumps.

4.1 Pump Operation Modes

Each pump at an installation can be set to run in Auto, Off, Manual (Hand) and Manual /Hand Override modes. Auto, Off and Manual (Hand) are cycled through by using the corresponding select button for that pump.



4.1.1 Auto

The default configuration sets the MTDPC to auto mode.

In this mode the pump controller automatically controls pump operation. Pump operation is dependent upon the activation and deactivation level sensors, which are situated in the pit or reservoir.

There are two major modes of operation that allow the pump controller to be used for a wide variety of applications; discharge mode and charge mode.

4.1.1.1 Discharge Mode

In Discharge (Empty) mode, the duty pump will turn ON when liquid level rises above the duty pump activation level sensor. If the liquid level continues to rise to the standby pump activation sensor, then the Standby pump will also turn ON. Both pumps will remain ON until the liquid level falls below the deactivation level sensor/s. At this point the pump/s will switch OFF.

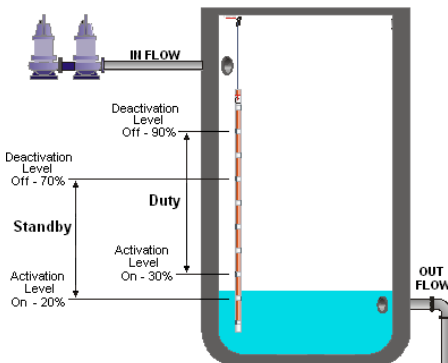
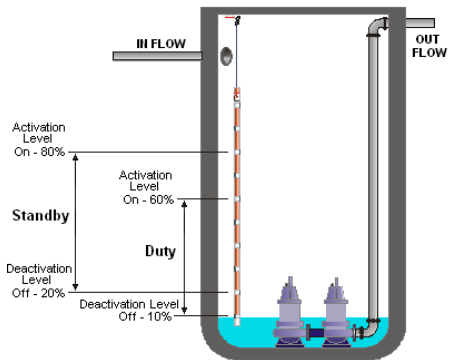

4.1.1.2 Charge Mode

In Charge (Fill) mode the opposite occurs, i.e. the pumps will switch ON when the liquid level falls below the activation level sensor, and will switch OFF when the liquid level rises above the deactivation level sensor.



For setting Charge and Discharge modes see Section 5.2.1.

4.1.2 OFF

Press the appropriate pump 'Select' button until the **OFF** LED is illuminated (flashing). The pump is now switched off.



4.1.3 Manual (Dual Function)

4.1.3.1 Manual (Hand) Mode

Press the appropriate pump 'Select' button until the **Manual (Hand)** LED illuminates.

Manual (Hand) mode allows an operator to start a pump prior to its activation level, provided the liquid level is within its working range. In this mode the pump will remain ON until the liquid level reaches the pump's deactivation level sensor. The pump will then be switched OFF and the controller will return to auto mode.

Example: (Discharge mode). The liquid level is above the pump deactivation sensor but has not yet reached the activation sensor. Press and release the pump 'Select' button until the **Manual (Hand)** LED is illuminated. The pump will start and continue to run until the liquid level reaches the deactivation point. At this point the pump will stop and the controller will revert to auto mode.



4.1.3.2 Manual Override Mode

Manual/Hand override allows a pump to operate outside its normal operating range. (This mode is useful for pumping a well dry.) Illuminate the **Manual (Hand)** LED using the appropriate 'Select' button, and then keep the button held in continuously. When the 'Select' button is released, the pump will return to either:

- A - Manual mode (if the liquid level is within its operating range), or
- B - Auto mode (if the liquid level is outside its operating range).

Example: (Discharge mode). You wish to empty a tank to perform maintenance and the liquid level is above the pump deactivation sensor but has not yet reached the activation sensor. Select **Manual (Hand)** using the appropriate pump 'Select' button, ensuring that the button remains held on. The controller is now in Manual/Hand Override mode. The pump will continue to run, regardless of the liquid level, provided the 'Select' button remains held on. When the tank is empty, release the 'Select' button and the pump will stop.

4.1.4 Running Indicator

The **Running** LED is used to indicate the pump's status. When the LED is on continuously, the pump is running.

If the **Running** indicator is flashing quickly (2Hz) the pump is about to start.

If the **Running** indicator is flashing slowly (1Hz) the pump is about to stop.



4.2 Analysing Pump Status

4.2.1 Pump Fault Indication

The pump controller continually evaluates pump fault information and displays the current pump fault status on the front panel. The pump controller displays a fault in three ways: present unacknowledged or cleared.

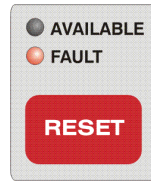

- **Present:** A fault condition exists. (Indicator Flashing Quickly – 2Hz)
- **Unacknowledged:** A fault has occurred but no longer exists. If the fault was a critical fault the pump will remain unavailable until reset by the operator (Indicator Flashing Slowly – 1Hz).
- **Cleared:** A fault, which has occurred, is no longer present and has been reset by the operator (Indicator OFF).

The pump controller has two primary fault types:

- Non-critical
- Critical

A non-critical fault makes a pump unavailable when the condition is present and returns the pump back to available when the condition clears. This type of fault is known as an auto reset fault, as operator intervention is not required.

A critical fault makes a pump unavailable in both present and unacknowledged fault conditions. This is known as a manual reset fault, as it requires operator intervention by pressing the appropriate 'Reset' button, to make the pump available again.

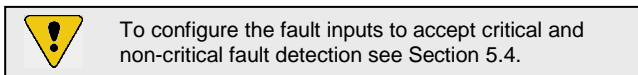

Pressing the appropriate pump 'Reset' button clears unacknowledged faults. However, after non-critical faults have been rectified, there is a factory default delay of 30 seconds before the pump is made available.

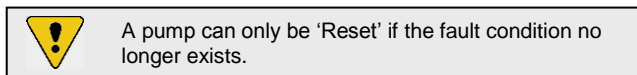

The diagram below summarises how pump faults are processed.

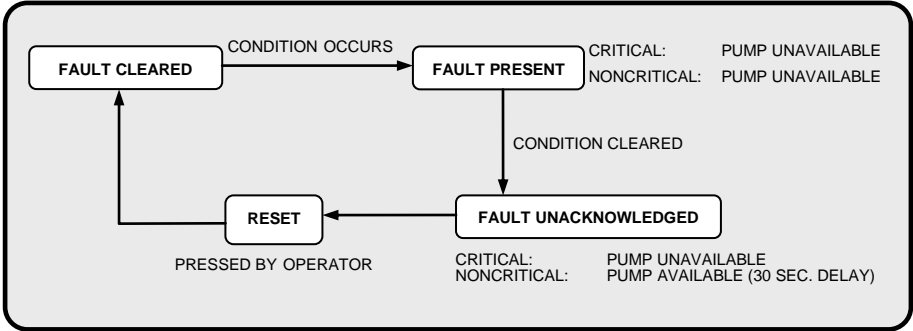

The table below summarises how faults are indicated on the control panel.

FAULT LED	FLASHING QUICKLY (2Hz)	FLASHING SLOWLY (1Hz)	OFF
MTDPC IN Non-critical mode	Fault Present	Unacknowledged Fault. There is a factory default delay of 30 seconds before the pump is made available. Press reset button to clear.	No Fault Exists
MTDPC IN Critical mode	Fault Present	Unacknowledged Fault, press reset button to clear.	No Fault Exists

A pump can only be 'Reset' if the fault condition no longer exists.

4.2.2 Pump Availability

The **Available** LED shows the available status for that pump. If the LED is Off, the pump is unavailable. If the LED is On, the pump is available for use.

Any of the following items can make a pump unavailable:

- Critical or non-critical fault is present
- A critical fault is unacknowledged
- The pump is decommissioned (see Section 5.5).





4.3 Level Alarm Indicators

An important feature of the level control process is the ability to report abnormal level conditions. The MultiTrode pump controller provides two different level alarms. These can be configured as high level or low-level alarms, in either charge or discharge modes.

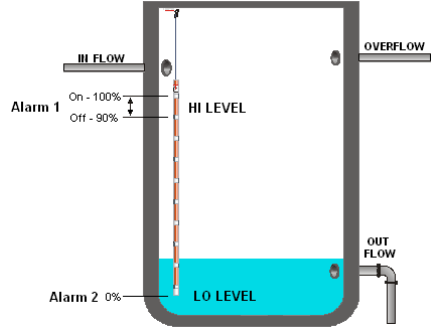

The Level Alarms will operate as high level alarms if their activation levels are set higher than the duty pump activation level or they can be set as low level alarms if their activation levels are set lower than the duty pump activation level.



 To configure the Level Alarm settings see Section 5.3.

When a level alarm is present, the appropriate alarm indicator will flash quickly (2Hz). When the alarm condition no longer exists and is unacknowledged, the indicator will flash slowly (1Hz).

To reset an unacknowledged alarm, press the **Alarm Reset** button.

 Only unacknowledged alarms may be reset. Present alarms may not be reset as the alarm condition still exists.

4.3.1.1 Muting Level Alarms

To mute a present level alarm, press and hold the **Alarm Reset** button for 5 seconds. This turns OFF the alarm until the level alarm condition no longer exists. A steady 'Alarm' LED indicates this mode has been activated.

 Muting of alarms allows service personnel to perform maintenance without having to endure loud alarms and flashing lights.

4.4 Duty Pump Alternation (Next To Start)

For installations with dual pump capability, pumps can be alternated so they share the workload thus protecting pumps from over temperature and excessive wear problems. This is the **default** setting.

Each pump at an installation takes a turn at running. This means that after each successive pump run a new pump is designated as the next to start.

Example (For a two-pump installation): When the unit is initialised the next to start pump is designated to physical pump 1. Since this is the first pump to start it is called the duty pump. The other pump is known as the standby pump.

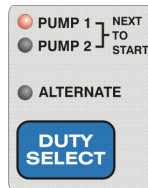

Rising liquid levels start this pump at the duty pump's activation level and the pump stops when the duty pump's deactivation level is reached. The controller's alternation program determines that the 'next to start' pump is now physical pump 2. As this is now the next pump to start, it takes over the duty pump role.

This example has shown that two separate physical pumps have operated as the duty pump and maintained their separate physical identities.



The 'Next to Start' LEDs show which pump will start next. If no pump lights are on, then all pumps must be either running, decommissioned or unavailable.

For most applications, the default pump alternation setting, as described above, will be sufficient and will require no adjustment. Alternatively, the pumps can be set to operate in a fixed sequence.

A fixed sequence is used when alternating pumps is undesirable. See Section 5.6 to establish alternation and fixed sequence settings.

5 Configuration

This section will take you through a series of logical steps that will enable you to configure the pump controller to your specific requirements.

5.1 Configuring Level Devices

The pump controller has been designed to be connected directly to MultiTrode probes, either with a number of discrete level probes or the standard 10-sensor probe.

It is possible to use ball float switches, if preferred.

5.1.1 Adjusting for Single/Multi Sensor Input (Function Switch 2)

Use function switch 2, on the pump controller, to adjust for either single or multi level sensing devices.

For correct wiring configuration, see Section 2.2.3.

The table below summarises the sensor settings.

SWITCH 2	DESCRIPTION
OFF	Multiple sensor probe with failed sensor detection (default)
ON	Single sensor probe. (Refer Note below)

Function Switch 2 (Located on the controller) is used to adjust for level sensing types, 10 or single sensor.

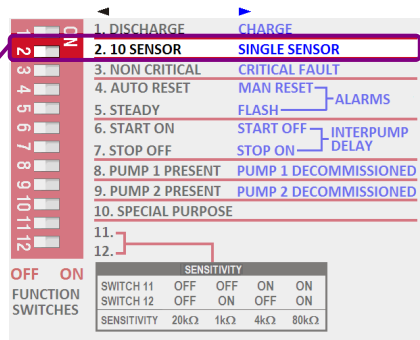

When in single sensor mode, a sensor must be placed at every point where an activation or deactivation point has been set.

5.1.2 Adjusting Probe Sensitivity (Function Switch's 11 & 12)

MultiTrobe probes are conductive sensing devices. As each sensor is submerged in liquid, a current path is created from the controller to the earth and is displayed on the level indicator.

As different liquid types have varying conductive properties it may be necessary, in some cases, to adjust the sensitivity of the probe to allow the controller to accurately display the liquid level.

The pump controller's probe sensitivity can be set to 1kΩ, 4kΩ, 20kΩ (Default Setting) or 80kΩ.

The table below summarises the sensitivity settings and the liquid environments in which they relate.

SWITCH 11	SWITCH 12	SENSITIVITY
OFF	OFF	20kΩ Plain Water (Default Setting)
OFF	ON	1kΩ Highly Conductive Liquids
ON	OFF	4kΩ Brine and Salt Water
ON	ON	80kΩ Oil and Fatty Liquids

Function Switches 11 and 12 are used to adjust the sensitivity of the probes.

12 FUNCTION SWITCHES

SWITCH 11	SWITCH 12	SENSITIVITY
OFF	OFF	20kΩ
OFF	ON	1kΩ
ON	OFF	4kΩ
ON	ON	80kΩ



As MultiTrobe probes are conductive sensing devices, the higher the conductivity of the liquid, the lower the sensitivity setting required and inversely, the lower the liquid conductivity, the higher the sensitivity setting required.

5.2 Setting Pump Levels

This section describes the procedures and function switches used when setting the activation and deactivation level sensing parameters for the pump controller.

5.2.1 Charge/Discharge Mode (Function Switch 1)

The MultiTrode Dual Pump Controller can be used in either charge (Fill) or discharge (Empty) mode.

The table below summarises the mode settings.

SWITCH 1	DESCRIPTION
OFF	Discharge mode (Empty) - Default Setting.
ON	Charge mode (Fill)

Function Switch 1 is used to switch between charge and discharge modes.

		SENSITIVITY			
SWITCH 11	OFF OFF ON ON	ON	ON	ON	ON
SWITCH 12	OFF ON OFF OFF ON	OFF	OFF	ON	ON
SENSITIVITY	20kΩ 1kΩ 4kΩ 80kΩ				

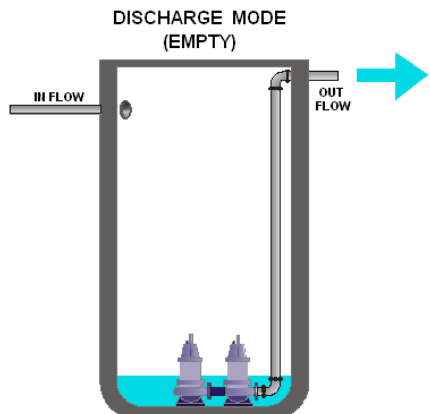
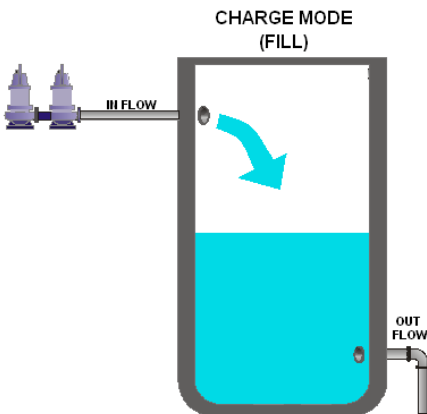

5.2.2 Activation / Deactivation Level Settings

Use the procedure below to electronically position the activation or deactivation sensor levels that are to be used within your pit, tank or reservoir.

1. Press  &  buttons simultaneously.

The Pump and Alarm LEDs are now flashing.

2. Press one of the following buttons to select which pump level to adjust.

 LEAD = Duty pump 1

 LAG = Standby pump 2

The Running LED for the selected pump will now be lit and the level indicator alternates between the current activation and deactivation points.

3. Press one of the following buttons to select which point to adjust.

 = (HI point) This is the 'ON' point in discharge and 'OFF' for charge mode.

 = (LO point) This is the 'OFF' point in discharge and 'ON' for charge mode.



 = Exits and returns to normal operation without altering levels. Useful if operator is checking current activation and deactivation points.

4. Raise or lower the level using the following keys.

 = Raise level

 = Lower level

 The 'Duty Select' button can be used to discard the changes and return to normal operation.

5. Save the new settings by pressing the  button or to discard the changes and return to normal operation, press the  button.
6. Repeat steps 1 through 5 to set each setpoint.

5.3 Setting Level Alarms

Use the procedure below to set level alarms for each pump connected to the controller.

1. Press  &  buttons simultaneously.

The Pump and Alarm LEDs are now flashing.

2. Press  to set alarm levels.
3. Press one of the following buttons to select which alarm to adjust.

 = Alarm 1.

 = Alarm 2.

 = Exits and returns to normal operation without altering levels.

The level indicator alternates between the current activation and deactivation points.

4. Press one of the following buttons to select which setpoint to adjust.

 Activation point (HI level alarm) or deactivation point (LO level alarm)

 Deactivation point (HI level alarm) or activation point (LO level alarm).

 Exits and returns to normal operation without altering levels. Useful if operator is checking current activation and deactivation points.



5. Raise or lower the level using the following keys.

 Raise level

 Lower level



The 'Duty Select' button can be used to discard the changes and return to normal operation.

6. Save the new settings by press the  button or to discard the changes and return to normal operation, press the  button.
7. Repeat steps 1 through 6 to set each setpoint.

5.3.1 Level Alarm Auto / Manual Reset (Function Switch 4)

The level alarm relays can be set to one of two modes of operation.

SWITCH 4	DESCRIPTION
OFF	AUTO RESET - When alarm condition is no longer present, alarm relay will be deactivated (Default Value).
ON	MAN RESET - When alarm condition is no longer present, alarm relay will remain activated until manually reset by the operator.

5.3.2 Level Alarm Flash/Steady (Function Switch 5)

The level alarm relay can be made to hold a steady state or to flash when activated. This removes the need for additional timers within the system.

SWITCH 5	DESCRIPTION
OFF	Steady (default)
ON	Flashes once every two seconds.

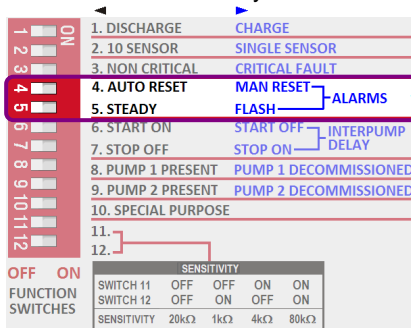

5.4 Critical & Non Critical Fault Selection (Function Switch 3)

A critical fault makes a pump unavailable when a fault is present or unacknowledged. This type of fault requires operator intervention to make the pump available again.

A non-critical fault makes a pump unavailable when the condition is present and available again (after a 30-second delay) when the condition clears without having to be reset manually. This type of fault is known as an auto reset fault, as operator intervention is not required.

SWITCH 3	DESCRIPTION
OFF	Non Critical Fault (default)
ON	Critical Fault

See Section 4.2 (Analysing a pump's status) for a description on how faults are indicated on the panel.

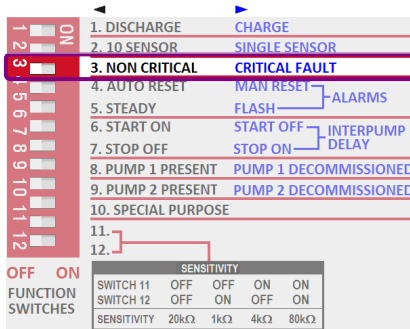

5.5 Decommissioning Pumps (Function Switches 8 & 9)

This function makes the pump unavailable to the pump controller, particularly for single pump installations or to decommission a pump for maintenance purposes.

SWITCH 8	DESCRIPTION
OFF	Pump 1 is present (default).
ON	Pump 1 is decommissioned.

SWITCH 9	DESCRIPTION
OFF	Pump 2 is present (default).
ON	Pump 2 is decommissioned.

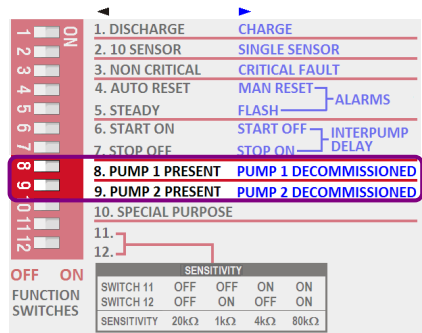

If a pump is recommissioned or an additional pump is added to the system, the appropriate function switch will have to be set to 'Present'.

5.6 Setting the Alternate/Fixed Pump Sequence

To cycle through alternate and fixed pump sequence, press and hold the **DUTY SELECT** button for 3 second intervals until the desired mode is selected.

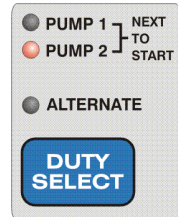

Alternate LED is ON:
Pump 1 LED is ON:
Pump 2 LED is ON:

Controller is alternating between the pumps
Physical pump 1 fixed as Duty pump
Physical pump 2 fixed as Duty pump

6 Configuration Quick Start

MultiTrobe has pre-programmed the controller with **FACTORY DEFAULT** settings to suit most applications. Little or no adjustment should be necessary in the majority of cases. Prior to installation, check the following.

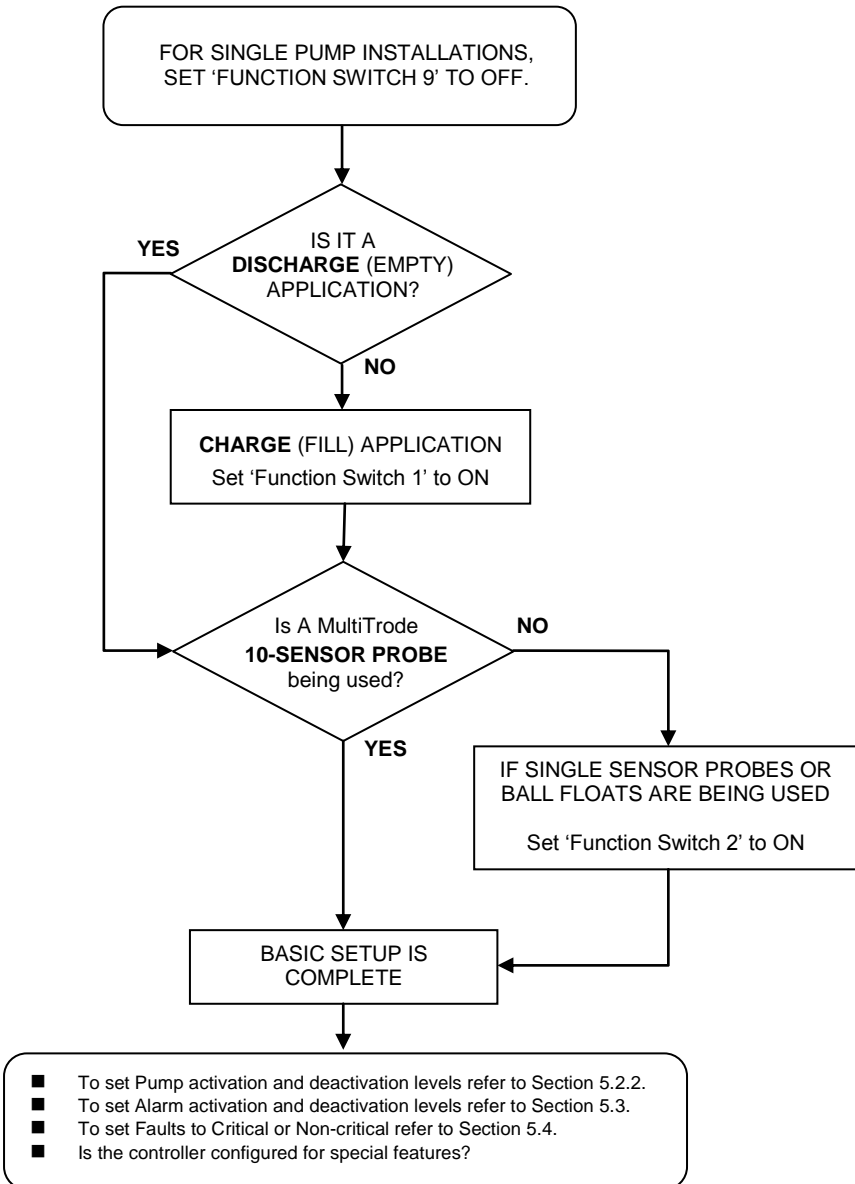

7 Special Features

7.1 Simulating Levels for Commissioning Purposes

Ideal for operators to test all pumps and alarms without waiting for levels to change and eliminates the dangerous process of entering a pit to manually adjust sensor positions.



The pump controller can simulate levels for commissioning purposes. This function allows the operator to increase or decrease the level in 10% steps via the keypad. This enables the total system to be tested before it is installed at the pump site.



Level commissioning mode is entered by

1. Simultaneously press  &  buttons.

In this mode the HI and LO LEDs flash alternately.

2. Raise or lower the simulated level in 10% steps.

  = Raise level

  = Lower level



This function will automatically time out after 30 seconds of inactivity.

The level indicator will show a simulated level, which activates pumps and alarms at their appropriate activation and deactivation levels.

3. Press  to exit this mode and return to normal operation.

7.2 Automatic Sensor Fault Detection

As a special feature, when using any MultiTrobe probe for level sensing, the pump controller automatically detects if a probe sensor not working correctly.

For example: If a standard ten-sensor probe is being used, and a sensor becomes defective, it will be displayed on the Level indicator as a flashing LED.

This function indicates that the probe requires inspection.

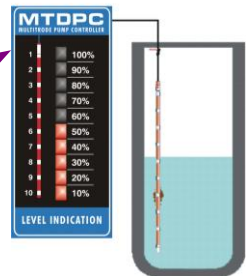

For installations where single sensor probes or ball floats are being used, the pump controller automatically determines whether or not a sensor has a pump or alarm activation or deactivation level connected to it. Only those level positions connected to a sensing device will flash if a malfunction occurs.

7.3 Interpump Delays

This helps to protect the system from turbulence and power surges.

The Interpump delay sets a time delay between any two pumps starting or stopping. This reduces liquid turbulence and excessive loading on the electricity supply caused by multiple pumps starting or stopping simultaneously.

7.3.1 Interpump Start Delay (Function Switch 6)

The interpump start delay sets a 15 second delay between any two pumps starting.

SWITCH 6	DESCRIPTION
OFF	15 second delay (default)
ON	No Delay



The pump controller will override this constraint when a pump is moved to 'Manual' mode.

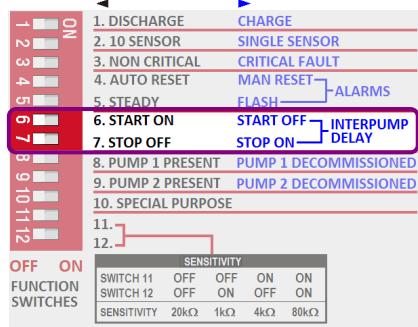

7.3.2 Interpump Stop Delay (Function Switch 7)

The interpump stop delay sets a 15 second delay between any two pumps stopping.

SWITCH 7	DESCRIPTION
OFF	No Delay (default)
ON	15 second delay



The pump controller will override this constraint in the event of pump faults occurring or the pumps are turned 'OFF'.

7.4 LED Test

The LED test may be performed at any time to check that the LEDs are working.

Simultaneously press 'Reset One', 'Reset Two' and 'Alarm Reset'.

The test will cycle through the LEDs, column by column. The test does not affect the controller's operation.

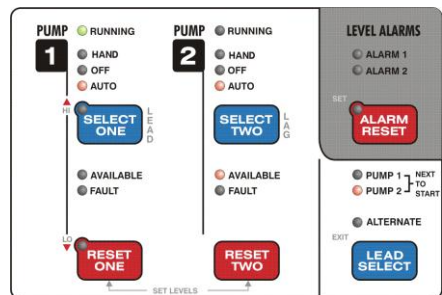

8 Default Settings

The pump controller is supplied with “plug’n’play” default settings in both activation/deactivation levels and manually controlled function switches.

8.1 Activation / Deactivation Default Levels

8.1.1 Default Level Settings

For most applications the default activation and deactivation liquid level settings should be appropriate for correct operation and should need no adjustment after installation. These levels are shown in the table below and may be changed as required.

Pump	DISCHARGE DEFAULT LEVEL %		CHARGE DEFAULT LEVEL %	
	Activation	Deactivation	Activation	Deactivation
Duty	50	10	50	90
Standby	60	20	40	80

To change default setting see Section 5.2.2.

8.1.2 Default Level Alarm Settings

The pump controller is pre-programmed with a set of alarm activation and deactivation levels. The common alarm relay default is set to activate when **ANY** pump fault is unacknowledged. These are shown in the table below and may be changed as required.

Alarm	DEFAULT LEVELS	
	Activation	Deactivation
Alarm 1	100	90
Alarm 2	Disabled	Disabled
Common	Set to activate when ANY pump fault is present	

To change default setting, see Section 5.3

8.1.3 Default Pump Alternation Setting

For most dual pump applications the default pump alternation setting will work correctly. The default pump alternation setting gives each pump in an installation a turn at being the duty pump. To change this default setting, see Section 5.6.

8.2 Function Switch Default Settings

The function switches (located on the controller) are used to manually change function settings.

DIP SWITCH	DEFAULT POSITION	DESCRIPTION	DIP SWITCH	DEFAULT POSITION	DESCRIPTION
1	Off	Discharge	7	Off	Stop Off - No Interpump stop delay
2	Off	10 Sensor	8	Off	Pump 1 Present
3	Off	Non Critical Fault	9	Off	Pump 2 Present
4	Off	Auto Reset Alarm	10	Off	Special Purpose
5	Off	Steady Alarm	11	Off	Sensitivity Set to 20kΩ
6	Off	Start On - 15 sec Interpump start delay	12	Off	

8.3 Resetting Controller Defaults

All keypad configurable settings within the MultiTrod Dual Pump Controller can be returned to their default state by performing a full reset. This function may be helpful if the pump controller is transferred from one site to another. The full default reset returns all Levels, Alarms and Alternation information to their default values.

To perform a full default reset:

1. Simultaneously press   and  buttons.

A LED test commences.

2. During the lamp test press  once.

3. When the LED test finishes, the 'LO' LED will flash.

Whilst the 'LO' LED is flashing press  once.

A buzzer will sound for two seconds and the LED test will recommence.

This completes the full reset.

CAUTION

Resetting a unit will stop all running pumps without interpump delays and reset all faults and alarms.

9 Specifications

Mode of Operation Charge or Discharge (Fill or Empty) Pump Alternation	Selectable via Function Switch Auto or Fixed: Selectable from Keypad
Level Sensing Probe Inputs Number of inputs Output voltage Output current Sensitivity settings Maximum cable length	10 2.5VAC Nominal (open circuit) 0.8mA max (per sensor) 1k, 4k, 20k and 80kΩ. Selectable via Function Switch Probe cable capacitance is compensated up to 1km (Recommended maximum cable length 50m, contact MultiTrodde if longer lengths required)
Fault Input Critical or Non Critical	Selectable for each pump via Function Switch (Operated by voltage free contact)
Relay outputs No. of relay outputs Relay contact rating Relay contact life	2 pump, 2 alarm (Steady or Flashing), 1 common alarm 250VAC 5A Resistive, 2A Inductive 300000 Operations at 2A
Displays LEDs	Hi intensity LEDs (Red & Green)
Physical Product Controller Dimensions mm Material Mounting Terminal size IP rating Keypad Dimensions (mm) Material Mounting	H 95 x W 95 x D 145 Aluminium & Polycarbonate DIN rail mounted 2.5 mm ² , # 13 IP20 H 105 x W 175 x D 24 Polycarbonate Panel mounted
Power Supply Supply voltage AC MTDPC 2 Supply voltage AC MTDPC 3 Power consumption	240VAC nominal 50/60Hz 110VAC nominal 50/60Hz 6VA max.
Environmental Range Operating temperature Humidity	-10° to +60° C (+14° to +140° F) 90% non condensing

10 MTDPC Connectors & Dip Switch

Models available:

MTDPC2 240VAC

MTDPC3 110VAC

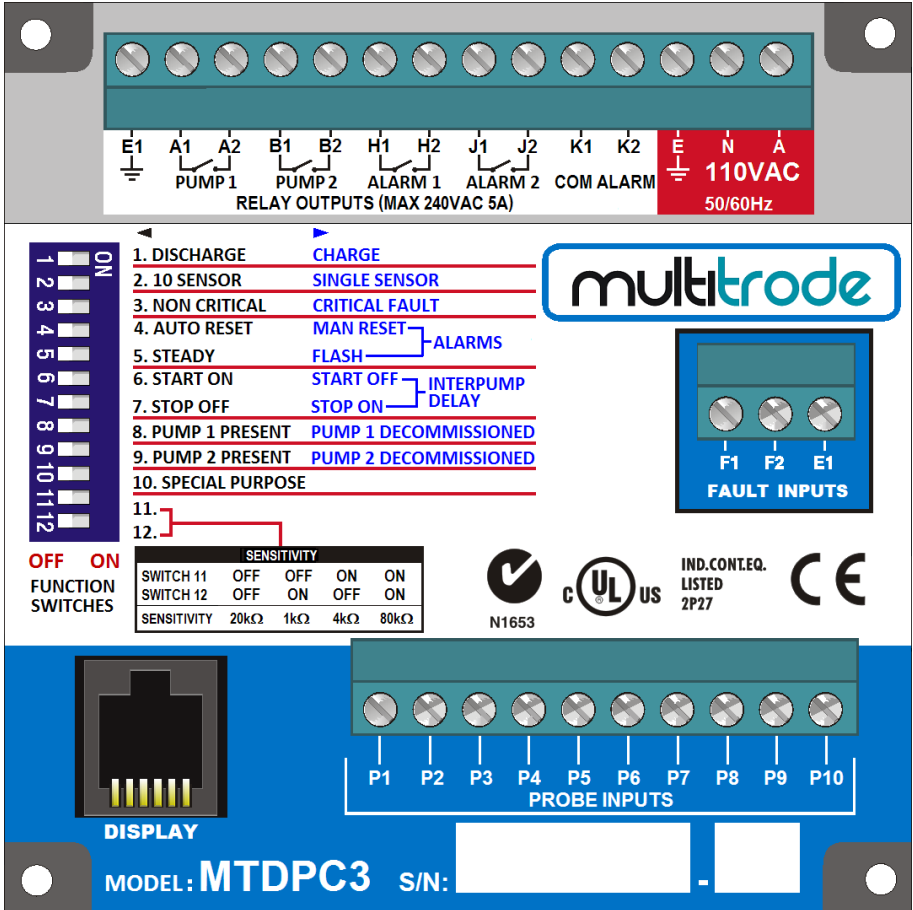

11 Glossary of Terms

Activation Level	The point at which a pump or alarm is switched On.
Alternate Mode	The pump controller is automatically alternating (switching or changing) between the two pumps.
Charge Mode	When the pump controller is set to fill a tank or pit.
Cleared Fault	A fault that has occurred, is no longer present, and has been reset by the operator.
Deactivation Level	The point at which a pump or alarm is switched “Off”.
Decommissioned Pump	A pump that has been removed from duty or an installation, e.g. for maintenance purposes.
Discharge Mode	When the pump controller is set to empty a tank or pit.
Duty Pump	The main pump or the first pump to start within a pumping cycle.
Fixed Sequence	Pump 1 or pump 2 is fixed as the duty pump.
Interpump Start Delay	The delay between any two pumps starting.
Interpump Stop Delay	The delay between any two pumps stopping.
Present Fault	A current fault condition exists.
Standby Pump	The secondary pump or the next pump to start within a pumping cycle.
Probe	MultiTrobe manufactures a range of conductive level sensors. They have many advantages over traditional devices such as ball floats. Advantages include: resistance to fatty deposit build-up, tangle-free and an adjustable sensitivity to liquid to prevent false readings.
Unacknowledged Fault	A fault has occurred but no longer exists and has not been acknowledged.

12 List of Abbreviations Used

Ω	Resistance Value (Ohm)
EMC	Electromagnetic Compatibility
Hz	Frequency (Hertz)
LED	Light Emitting Diode
MTDPC	MultiTrobe Dual Pump Controller
N/O	Normally Open
VAC	Alternating Current Voltage
VDC	Direct Current Voltage

PROBES

- Little maintenance required
- Cost-savings, short and long term
- Resistant to fat, grease, debris and foam

MultiTrode probes are specifically designed for the arduous, turbulent conditions encountered in water, sewage and industrial tanks & sumps.

MultiTrode offers a large variety of off-the-shelf probes or we can manufacture them to your exact requirements.



Probe Parameters

No. of Sensors

25 max

Sensor spacing

100mm (4") min

Section length

3m (9ft) max

Cable Length

50m (164ft)
(recommended max.)

MTAK-1 & MTAK-2

Standard mounting Bracket

The MTAK-1 standard mounting bracket kit is supplied with all multi-sensor probes and is made from 2.5mm 316 stainless steel. The kit also includes a stainless steel hook and cable ties.

The MTAK-2 is an optional extra available where longer reach is required and is only supplied on order.

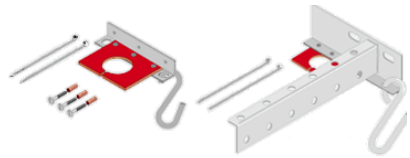

MTTS

Transient Suppressors

The MTTs helps protect MultiTrode equipment from transients such as the secondary effects of lightning entering through inputs.



www.multitrode.com



**MultiTrode UK Ltd –
Europe, ME & Africa
Operations**

Unit 5, Kingswood Court
Long Meadow, South Brent
Devon, England TQ10 9YS
Tel: +44 1752 547355
Fax: +44 1752 891932

E-mail:
UKsales@multitrode.com

**MultiTrode Pty Ltd –
Head Office**

Brisbane Technology Park
18 Brandl Street
Eight Mile Plains Qld 4113
Australia
Ph: +61 7 3340 7000
Fax: +61 7 3340 7077

E-mail:
AUsales@multitrode.com

**MultiTrode Inc –
USA**

Unit 3, 990 South Rogers
Circle
Boca Raton Florida 33487
Tel: +1 561 994 8090
Fax: +1 561 994 6282

E-mail:
USSales@multitrode.net