

DETAIL A
SCALE 0.286

DIMENSIONS ARE SUBJECT TO CHANGE, NOT TO BE USED FOR CONSTRUCTION PURPOSES UNLESS CERTIFIED.

DIMENSIONS- Inches (mm)			STANDARD SEAL 1510, 1510-F														WEIGHT	OPERATING
MOTOR FRAME	MOTOR KW	MOTOR RPM	HA	HB	HC MAX	HD	2HE	HF1	HF2	HH	HL	HM MAX	HO	HP	Y	Z	kg. APPROX	WEIGHT kg. APPROX
132S	5.5	1450	16 (406)	46-1/2 (1181)	46-1/2 (1181)	15 (381)	14 (356)	36-1/2 (927)	18-1/4 (464)	7/8 (22)	8-3/8 (213)	20-3/8 (518)	25-1/2 (648)	5 (127)	7 (178)	8-1/4 (210)	322	403
132M	7.5	1450	16 (406)	46-1/2 (1181)	46-5/8 (1184)	15 (381)	14 (356)	36-1/2 (927)	18-1/4 (464)	7/8 (22)	8-3/8 (213)	20-3/8 (518)	25-1/2 (648)	5 (127)	7 (178)	8-1/4 (210)	332	415
160M	11	1450	16 (406)	46-1/2 (1181)	50-5/8 (1286)	15 (381)	14 (356)	36-1/2 (927)	18-1/4 (464)	7/8 (22)	8-3/8 (213)	21-7/8 (556)	25-1/2 (648)	5 (127)	7 (178)	8-1/4 (210)	395	494
160L	15	1450	16 (406)	46-1/2 (1181)	52-3/8 (1330)	15 (381)	14 (356)	36-1/2 (927)	18-1/4 (464)	7/8 (22)	8-3/8 (213)	21-7/8 (556)	25-1/2 (648)	5 (127)	7 (178)	8-1/4 (210)	417	521
180M	18.5	1450	16 (406)	51-3/4 (1314)	53-1/8 (1349)	15 (381)	14 (356)	41-3/4 (1060)	20-7/8 (530)	7/8 (22)	8-3/8 (213)	23 (584)	25-1/2 (648)	5 (127)	7 (178)	8-1/4 (210)	495	618

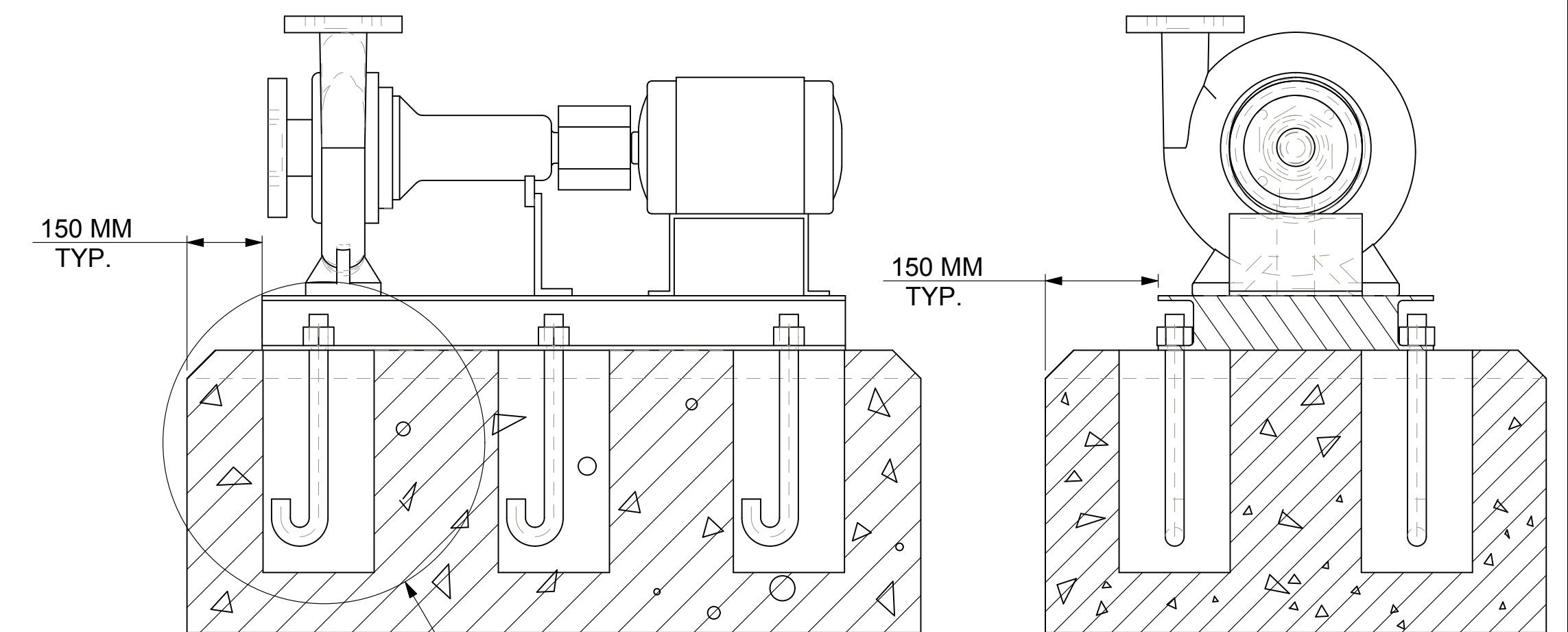

DEVIATION FOR LINEAR DIMENSIONS ARE AS PER IS:2102 VERY COARSE CLASS.

ABOVE	0.5	3	6	30	120	400	1000	2000
UP TO & INCLUDING	3	6	30	120	400	1000	2000	4000
VERY COARSE CLASS	± 0.5	± 1.0	± 1.5	± 2.5	± 4.0	± 6.0	± 8.0	

MAXIMUM WORKING PRESSURE 175 PSI (12 BAR)
FLANGES ARE 125# ANSI - STANDARD

FLANGE DIMENSIONS IN INCHES (MM)						
	SIZE	O.D.	THICKNESS	PCD	HOLE DIA.	NO OF HOLES
DISCHARGE	6	12.13 (308)	1.44 (37)	9.50 (241)	0.88 (22)	8
SUCTION	8	14.75 (375)	1.63 (41)	11.75 (298)	0.88 (22)	8

MAXIMUM WORKING PRESSURE 232 PSI (16 BAR)

FLANGE DIMENSIONS IN INCHES (MM)						
	SIZE	O.D.	THICKNESS	PCD	HOLE DIA.	NO OF HOLES
DISCHARGE	6	12.13 (308)	1.44 (37)	9.45 (240)	0.88 (22)	8
SUCTION	8	14.75 (375)	1.63 (41)	11.61 (295)	0.88 (22)	12

- NOTE :
- 1) THE FOUNDATION TO BE MADE OF CONCRETE ON SOLID GROUND.
 - 2) FOUNDATION BOLTS & PACKER PLATES TO BE GROUTED WITH QUICK SETTING NON-SHRINK GROUT ONLY.
 - 3) RECOMMENDED MAKE : ACC "SHRINKKOMP" / FORSORC "CONBEXTRA-GP2" OR EQUIVALENT BALANCE HOLLOW PORTION OF BASEFRAME TO BE GROUTED WITH PORTLAND CEMENT, SAND & AGGREGATE IN PROPORTION OF 1:2:2 GRAVEL SIZE SHOULD BE < 18 TO 20 MM. AFTER FINAL GROUTING ALL SURFACE SHOULD BE FINISHED WITH FINE PLASTER.
 - 4) THE FOUNDATION MUST BE ATLEAST 2.5 TIMES THE WEIGHT OF THE PUMP UNIT.
 - 5) FOUNDATION DETAILS ARE FOR REFERENCE ONLY, SHOULD BE CONSTRUCTED BY CUSTOMER AS PER SITE REQUIREMENT ONLY.
 - 6) PUMP SET IMAGE IS PROVIDED FOR DIMENSIONS REFERENCE ONLY AND IS NOT TO SCALE.

REVISION	DATE	BY	CHKD.	APP.	REVISION	DATE	BY	CHKD.	APP.
03					MAXIMUM WORKING PRESSURE DETAIL CHANGED	09/06/14	VP	DJ	KS
02					FLANGE DETAIL ADDED	02/04/14	VP	DJ	KS
01					FOUNDATION DETAILS ADDED	12/02/13	DJ	NP	KS
00					ORIGINAL RELEASE	16/08/12	NP	DJ	KS

1510 6BC MODEL										DWG NO. 1510-6BC	
TITLE	DATE		CHKD.	DATE	SCALE	TOLERANCES UNLESS OTHERWISE SPECIFIED:				THIRD ANGLE PROJECTION	
DWN	NP	16/08/12	DJ	16/08/12	NTS	X.XE X.XXE XXXXE X.XXXXE ANGLE ± FRAC ±					
<small>THIS DRAWING AND THE INFORMATION DEPICTED THEREIN IS THE PROPERTY OF XYLEM. COPIES ARE ISSUED IN STRICT CONFIDENCE AND SHALL NOT BE REPRODUCED OR COPIED, OR USED AS THE BASIS FOR THE MANUFACTURE OR SALE OF PRODUCTS WITHOUT PRIOR WRITTEN PERMISSION OF XYLEM.</small>											
Xylem Water Solutions India Private Limited Plot No. 731, GIDC Savli, Manjisar, Savli Road, Vadodra-391 770, Gujarat, India. Tel : +91 2667 265800.											