

DIMENSIONS ARE SUBJECT TO CHANGE, NOT TO BE USED FOR CONSTRUCTION PURPOSES UNLESS CERTIFIED.

DIMENSIONS- Inches (mm)			STANDARD SEAL 1510, 1510-F														WEIGHT Kg. APPROX	OPERATING WEIGHT kg. APPROX	
MOTOR FRAME	MOTOR KW	MOTOR RPM	HA	HB	HC MAX	HD	2HE	HF1	HF2	HH	HL	HM MAX	HO	HP	Y	Z	F		
80	0.75	1450	12 (305)	28-3/4 (730)	29-1/2 (749)	9-3/4 (248)	10-1/4 (260)	22-1/2 (572)	---	3/4 (19)	4-5/16 (110)	13-3/8 (340)	15-3/4 (400)	3 (76)	4-1/8 (105)	5 (127)	5/8 (16)	95	119
90S	1.1	1450	12 (305)	28-3/4 (730)	29-5/8 (752)	9-3/4 (248)	10-1/4 (260)	22-1/2 (572)	---	3/4 (19)	4-5/16 (110)	13-1/2 (343)	15-3/4 (400)	3 (76)	4-1/8 (105)	5 (127)	5/8 (16)	107	134
90L	1.5	1450	12 (305)	28-3/4 (730)	30-5/8 (778)	9-3/4 (248)	10-1/4 (260)	22-1/2 (572)	---	3/4 (19)	4-5/16 (110)	13-1/2 (343)	15-3/4 (400)	3 (76)	4-1/8 (105)	5 (127)	5/8 (16)	110	138
100L	2.2	1450	14-5/8 (371)	31 (787)	33-3/8 (848)	9-3/4 (248)	12-7/8 (327)	25 (635)	---	3/4 (19)	4-5/16 (110)	15 (381)	15-3/4 (400)	3 (76)	4-1/8 (105)	5 (127)	5/8 (16)	128	160
132S	5.5, 7.5	2900	14-5/8 (371)	39-3/8 (1000)	42-5/8 (1083)	10-3/4 (273)	12-7/8 (327)	33-3/8 (848)	---	3/4 (19)	2-15/16 (75)	15-3/8 (397)	16-3/4 (425)	3 (76)	4-1/8 (105)	5 (127)	5/8 (16)	189	236
160M	11, 15	2900	16 (406)	46-1/2 (1181)	46-3/8 (1178)	13 (330)	14 (356)	36-1/2 (927)	18-1/4 (464)	7/8 (22)	4-1/16 (103)	18-7/8 (479)	19 (483)	5 (127)	4-1/8 (105)	5 (127)	3/4 (19)	259	324

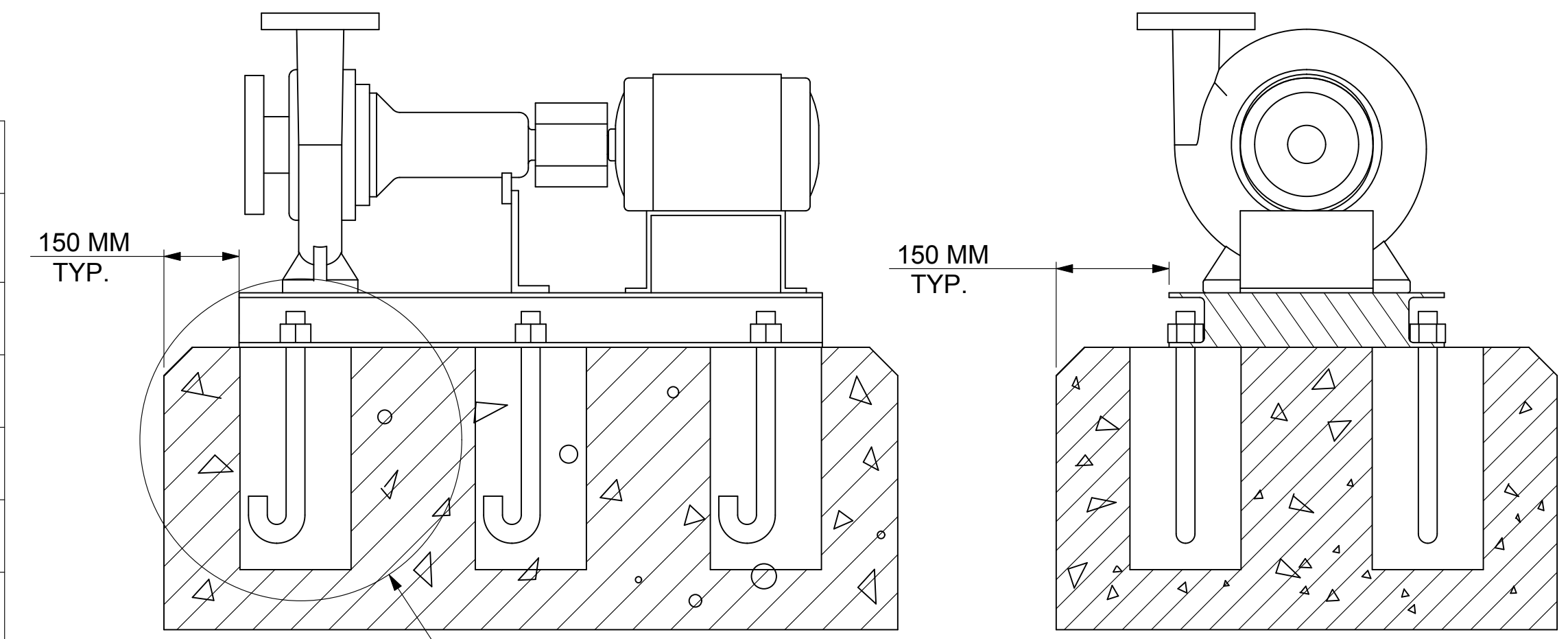

- NOTE :
- 1) THE FOUNDATION TO BE MADE OF CONCRETE ON SOLID GROUND.
 - 2) FOUNDATION BOLTS & PACKER PLATES TO BE GROUTED WITH QUICK SETTING NON-SHRINK GROUT ONLY.
 - 3) RECOMMENDED MAKE : ACC "SHRINKKOMP" / FORSORC "CONBEXTRA-GP2" OR EQUIVALENT BALANCE HOLLOW PORTION OF BASEFRAME TO BE GROUTED WITH PORTLAND CEMENT, SAND & AGGREGATE IN PROPORTION OF 1:2:2 GRAVEL SIZE SHOULD BE < 18 TO 20 MM. AFTER FINAL GROUTING ALL SURFACE SHOULD BE FINISHED WITH FINE PLASTER.
 - 4) THE FOUNDATION MUST BE ATLEAST 2.5 TIMES THE WEIGHT OF THE PUMP UNIT.
 - 5) FOUNDATION DETAILS ARE FOR REFERENCE ONLY, SHOULD BE CONSTRUCTED BY CUSTOMER AS PER SITE REQUIREMENT ONLY.
 - 6) PUMP SET IMAGE IS PROVIDED FOR DIMENSIONS REFERENCE ONLY AND IS NOT TO SCALE.

MAXIMUM WORKING PRESSURE 175 PSI (12 BAR)
FLANGE ARE 125# ANSI - STANDARD

FLANGE DIMENSIONS IN INCHES (MM)						
	SIZE	O.D.	THICKNESS	PCD	HOLE DIA.	NO OF HOLES
DISCHARGE	3	7.5 (191)	0.75 (19)	6 (152)	0.75 (19)	4
SUCTION	4	9 (229)	0.94 (24)	7.5 (191)	0.75 (19)	8

DEVIATION FOR LINEAR DIMENSIONS ARE AS PER IS:2102 VERY COARSE CLASS.

	ABOVE	0.5	3	6	30	120	400	1000	2000
UP TO & INCLUDING	3	6	30	120	400	1000	2000	4000	
VERY COARSE CLASS	---	± 0.5	± 1.0	± 1.5	± 2.5	± 4.0	± 6.0	± 8.0	

REVISION		DATE	BY	CHKD.	APP.	REVISION		DATE	BY	CHKD.	APP.
04	SUPPORT FOOT MOUNTING DIRECTION CHANGED	13/12/16	VP	KS	KS	00	ORIGINAL RELEASE	16/08/12	NP	DJ	KS
03	GENERAL TOLERANCE DETAILS ADDED	03/03/15	VP	DJ	KS						
02	MOTOR FRAME SIZE CORRECTED AND FLANGE DETAIL ADDED	21/02/14	VP	DJ	KS						
01	FOUNDATION DETAILS ADDED	12/02/13	DJ	NP	KS						

1510 3AC MODEL										DWG NO. 1510-3AC		
MATL	DWN	DATE	CHKD.	DATE	SCALE	TOLERANCES UNLESS OTHERWISE SPECIFIED:				THIRD ANGLE PROJECTION		
	NP	16/08/12	DJ	16/08/12	NTS	XXXE	XXXXE	XXXXE	XXXXE	ANGLE ±	FRAC ±	

THIS DRAWING AND THE INFORMATION DEPICTED THEREIN IS THE PROPERTY OF XYLEM. COPIES ARE ISSUED IN STRICT CONFIDENCE AND SHALL NOT BE REPRODUCED OR COPIED, OR USED AS THE BASIS FOR THE MANUFACTURE OR SALE OF PRODUCTS WITHOUT PRIOR WRITTEN PERMISSION OF XYLEM.

xylem Xylem Water Solutions India Private Limited
Plot No. 731, GIDC Savli, Manjusr, Savli Road, Vasodara-381 770, Gujarat, India.
Tel : +91 2667 266800.