

INSTALLER: PLEASE LEAVE THIS MANUAL FOR THE OWNER'S USE.

Series VSC[®] and VSCS[®] Base Mounted Centrifugal Pumps

(TO BE USED IN CONJUNCTION WITH VSC PARTS LIST CONTAINING LINE DRAWINGS)

DESCRIPTION

The VSC and VSCS Series centrifugal pumps are frame mounted pumps which feature – high efficiency, rugged construction, compact design, foot mounted volute, center drop out coupler, and regreasable bearings. These features along with the vertically split case make installation, operation, and service easy to perform.



This product can expose you to chemicals including Lead, which is known to the State of California to cause cancer and birth defects or other reproductive harm. For more information go to: www.P65Warnings.ca.gov.

PUMP APPLICATION

The standard VSC and VSCS Series centrifugal pump's bronze fitted construction make it ideal for service with the following liquids: unheated domestic and fresh water, boiler feed water, condensate, hydronic cooling or heating, pressure boosting, general pumping and benign liquids.

For other applications contact your local B&G Representative.

OPERATIONAL LIMITS

Unless special provisions have been made for your pump by Bell & Gossett, the operational limits for VSC/VSCS Series Pumps are as follows:

Maximum Working Pressure

Listed on pump nameplate.

SEAL OPERATING LIMITS

Standard Seals

BUNA-PH Limitations 7-9; Temperature Range -40 to +225°F
EPT-PH Limitations 7-11; Temperature Range -40 to +250°F
For use on closed or open systems which are relatively free of dirt and/or other abrasive particles.

Flushed Single Seals

PH Limitations 7-9; Temperature Range 0 to +250°F†

Note: On closed or open low pressure systems which may contain a high concentration of abrasives an external flush is required.

Flushed Double Seals

PH Limitations 7-9; Temperature Range 0 to +250°F

Note: On closed or open low pressure systems which may contain a high concentration of abrasives an external flush is required.

Packing

PH Limitations 7-9; Temperature Range 0 to +200°F

Note: On open or closed systems which require a large amount of makeup water, as well as systems which are subjected to widely varying chemical conditions and solids buildup.

† For operating temperatures above 250°F a cooled flush is required and is recommended for temperatures above 225°F for optimum seal life. On closed systems cooling is accomplished by inserting a small heat exchanger in the flush line to cool the seal flushing fluid.

Flush-line Filters and Sediment Separators are available on special request.



SAFETY INSTRUCTION

This safety alert symbol will be used in this manual and on the pump safety instruction decal to draw attention to safety related instructions. When used, the safety alert symbol means ATTENTION! BECOME ALERT! YOUR SAFETY IS INVOLVED! FAILURE TO FOLLOW THE INSTRUCTIONS MAY RESULT IN A SAFETY HAZARD.

Your VSC/VSCS Series Pump should have the following safety instruction decals located approximately as shown. If the decals are missing or illegible contact your local B&G representative for a replacement.

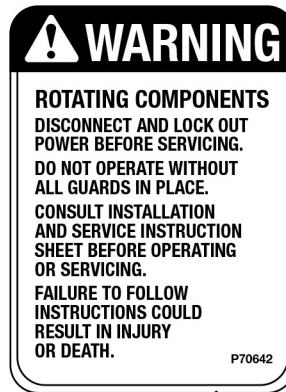
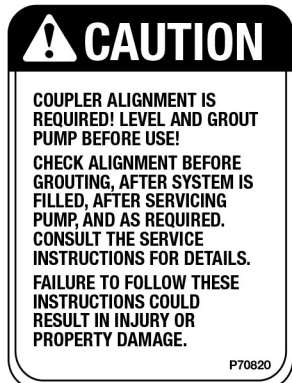

(2) REQUIRED
(1 EACH SIDE)

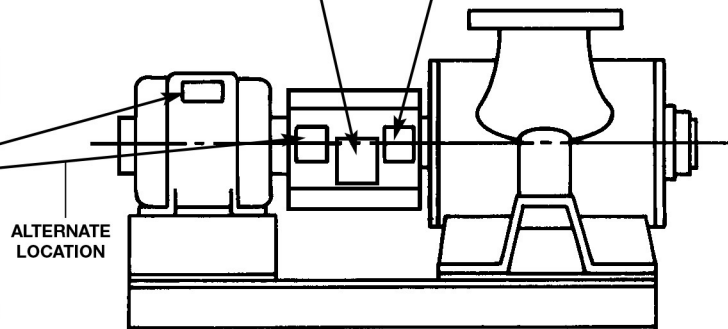

ADDITIONAL SAFETY REQUIREMENTS:

ELECTRICAL SAFETY:

WARNING: Electrical Shock Hazard
 Electrical connections to be made by a qualified electrician in accordance with all applicable codes, ordinances, and good practices. Failure to follow these instructions could result in serious personal injury or death, or property damage.

WARNING: Electrical Overload Hazard
 Three phase motors must have properly sized heaters to provide overload and undervoltage protection. Single phase motors have built-in overload protectors. Failure to follow these instructions could result in serious personal injury or death, or property damage.

THERMAL SAFETY:

WARNING: Extreme Temperature Hazard
 If pump, motor, or piping are operating at extremely high or low temperatures, guarding or insulation is required. Failure to follow these instructions could result in serious personal injury or death, or property damage.

MECHANICAL SAFETY:

WARNING: Unexpected Startup Hazard
 Disconnect and lockout power before servicing. Failure to follow these instructions could result in serious personal injury or death, or property damage.

WARNING: Excessive System Pressure Hazard
 The maximum working pressure of the pump is listed on the nameplate, do not exceed this pressure. Failure to follow these instructions could result in serious personal injury or death, or property damage.

WARNING: Excessive Pressure Hazard Volumetric Expansion
 The heating of water and other fluids causes volumetric expansion. The associated forces may cause failure of system components and release of high temperature fluids. This will be prevented by installing properly sized and located compression tanks and pressure relief valves. Failure to follow these instructions could result in serious personal injury or death, or property damage.

PUMP LOCATION

Locate the pump so there is sufficient room for inspection, maintenance and service. If the use of a hoist or tackle is needed, allow ample head room.

WARNING: Fall Objects Hazard
 Eyebolts or lifting lugs, if provided, are for lifting only the components to which they are attached. Failure to follow these instructions could result in serious personal injury or death, or property damage.

If lifting of the entire pump is required, do so with slings placed under the base rails as shown.

The best pump location for sound and vibration absorption is on a concrete floor with subsoil underneath. If the pump location is overhead, special precautions should be undertaken to reduce possible sound transmission, consult a sound specialist.

If the pump is not on a closed system, it should be placed as near as possible to the source of the liquid supply, and located to permit installation with the fewest number of bends or elbows in the suction pipe.

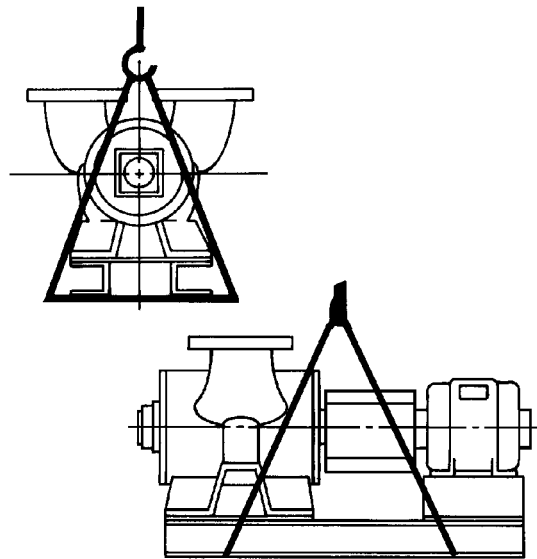
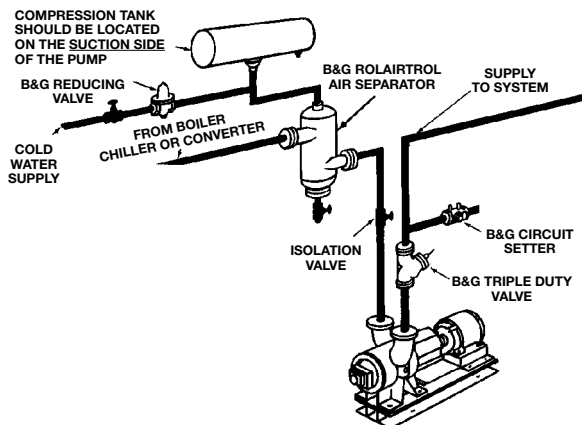

The installation must be evaluated to determine that the Net Positive Suction Head Available (NPSHA) meets or exceeds the Net Positive Suction Head Required (NPSHR), as stated by the pump performance curve.

IMPORTANT

Do not install and operate Bell & Gossett Pumps, 3D Valves, Suction Diffusers, etc., in closed systems unless the system is constructed with properly sized safety devices and control devices. Such devices include the use of properly sized and located pressure relief valves, compression tanks, pressure controls, temperature controls, and flow controls as appropriate. If the system does not include these devices, consult the responsible engineer or architect before making pumps operational.

INSTALLATION

This pump is built to provide years of service if installed properly and attached to a suitable foundation. A base of concrete weighing 2½ times the weight of the pump is recommended. (Check the shipping ticket for pump weight.)

If possible, tie the concrete pad in with the finished floor. Use foundation bolts and larger pipe-sleeves to give room for final bolt location. (See Figure 6A.)

LEVELING

Place the pump on its concrete foundation supporting it with steel wedges or shims totaling 1" in thickness. These wedges or shims should be put on both sides of each anchor-bolt to provide a means of leveling the base. (See Figure 6B.)

It is very important that the pump-base be set level to avoid any mechanical difficulties with the motor or pump. This pump was properly aligned (if furnished with a motor) at the factory. However, since all pump bases are flexible they may spring and twist during shipment. Don't pipe the pump until it is realigned. After piping is completed and after the pump is grouted-in and bolted-down, align it again. It may be necessary to re-adjust the alignment from time to time while the unit and foundation are new.

GROUTING

After the pump has been leveled, securely bolted to the floor, and properly aligned, a good grade of non-shrinking grout should be poured inside the pump base. To hold wedges or shims in place, allow the grout to flow around them.

ROTATION

The VSC & VSCS pump is available in both right- and left-hand rotation. An arrow cast into the pump body shows the direction of rotation.

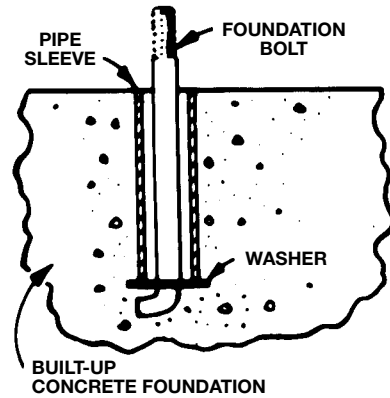

FIGURE 6A

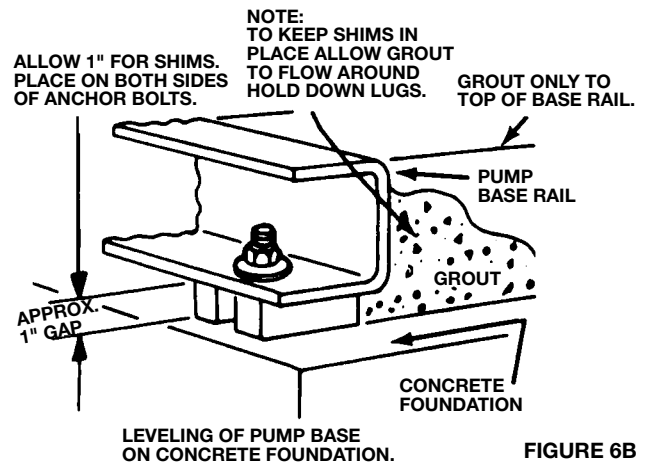
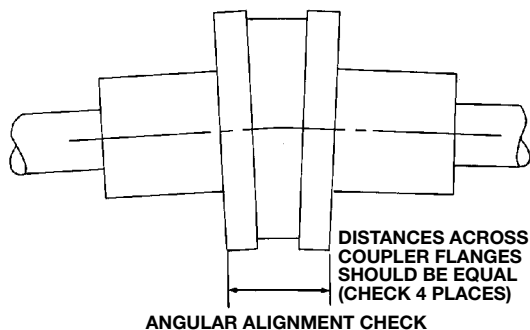
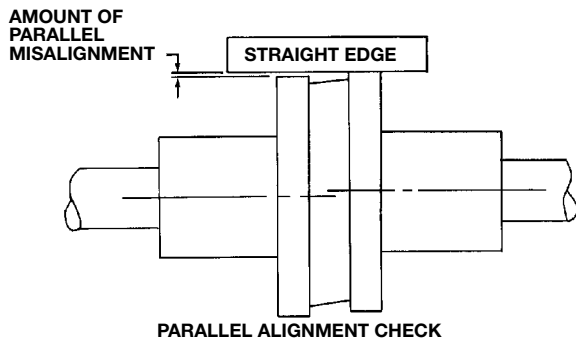

FIGURE 6B



COUPLER ALIGNMENT

All alignment should be done by moving or shimming the motor only. Adjustments in one direction may alter alignment in another. Therefore, check alignment in all directions after a correction is made. **Black rubber inserts have different horsepower load ratings than orange Hytrel sleeves. They should not be interchanged.**



WARNING: Unexpected Startup Hazard

Disconnect and lockout power before servicing. Failure to follow these instructions could result in serious personal injury or death, or property damage.

STANDARD SLEEVE TYPE COUPLER WITH BLACK RUBBER INSERT

Before aligning the coupler, make sure there is about 1/8" end clearance between the sleeve and the two coupler halves.

1. Check angular misalignment using a micrometer or caliper. Measure from the outside of one flange to the outside of the opposite flange at four points 90° apart. **DO NOT ROTATE COUPLER.** Misalignment up to 1/64" per inch of coupler radius is permissible.
2. At four points 90° apart (**DO NOT ROTATE COUPLER**), measure the parallel coupler misalignment by laying a straight edge across one coupler half and measuring the gap between the straight edge and opposite coupler half. Up to a 1/64" gap is permissible.

FOR FINE ALIGNMENT, ORANGE HYTREL INSERTS, 3500 RPM OPERATION, OR ALL OTHER COUPLER TYPES

Use a dial indicator when greater alignment accuracy is required. Use the following alignment tolerances unless specified otherwise by the coupler manufacturer. On sleeve type couplers make sure there is about 1/8" end clearance between the sleeve and the two coupler halves.

1. To check angular misalignment, mount the dial indicator base to one coupler half, or shaft, and position the dial indicator button on the front or rear face of the opposite coupler half. Set the dial to zero. Rotate both coupler halves **together**, making sure the indicator button always indicates off the same spot. Misalignment values within 0.004" TIR per inch of coupler radius are permissible.
2. To check parallel misalignment, mount the dial indicator base to one coupler half, of shaft, and position the dial indicator button on the outside diameter of the opposite coupler half. Set the dial to zero. Rotate both coupler halves **together**, making sure the indicator button always indicates off the same spot. Misalignment within 0.004" TIR is permissible.

PIPING

Always install a section of straight pipe between the suction side of the pump and first elbow. This reduces turbulence of the suction by straightening out the flow of liquid before it enters the pump. The length should be equal to five times the diameter of the suction pipe size.

Line up the piping so that the bolt-holes in the pump flanges match the bolt-holes in the pipe flanges. **DO NOT ATTEMPT TO SPRING THE SUCTION OR DISCHARGE LINES INTO POSITION.** Coupling and bearing wear will result if suction or discharge lines are forced into position. The code for Pressure Piping (ANSI B.31.1) lists many types of supports available for various applications.

When considerable temperature changes are anticipated, equipment for absorbing expansion should be installed in the system in such a way as to avoid strain on the pump.

When using an isolation base, flexible piping should also be used on both suction and discharge sides of pump.

On an open-system with a suction-lift, use a foot-valve of equal or greater area than the pump suction piping. Prevent clogging by using a strainer at the suction inlet next to the foot-valve. The strainer should have an area three times that of the suction pipe with hole diameter of no less than 1/4".

The pipeline should have isolation valves around the pump and have a drain valve in the suction pipe.

A Bell & Gossett Triple Duty Valve installed in the discharge line will serve as a check valve to protect the pump from water hammer, as a gate valve for servicing and for throttling.

PUMP INSULATION

When insulating a Series VSC/VSCS pump, ensure that the grease fittings remain accessible and visible. Do not seal off the drain holes in the bearing caps or bearing housings.

PRIMING AND STARTING



CAUTION: Seal Damage Hazard

Do not run pump dry, seal damage may occur. Failure to follow these instructions could result in serious property damage and/or moderate personal injury.

Before starting the pump, the pump body must be full of liquid. Manual priming may be required if the system does not automatically fill the pump body with liquid. Vent plugs are provided on the pump body to vent the air. While venting the air from the pump body the pump shaft should be rotated a few times by hand.

The pump should be started with the discharge valve closed and the suction valve fully open. After the pump is up to operating speed the discharge valve should be opened slowly.

IMPORTANT: The pump should never be operated with the suction valve closed or throttled. This could result in cavitation.

GENERAL INSTRUCTIONS

1. Keep this pump and motor properly lubricated.
2. Protect the motor against overload and low-voltage. Use a motor-starter with proper size heater elements.
3. When there is danger of freezing, remove the plugs at the top and bottom of the volute shell.

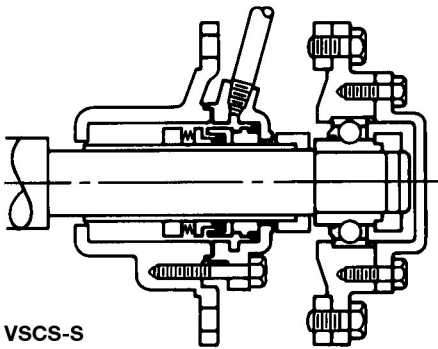

VSCS-S

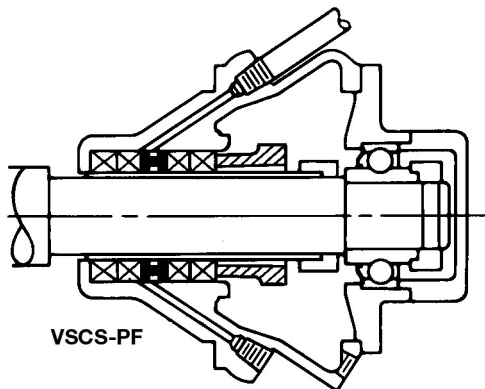

VSCS-PF

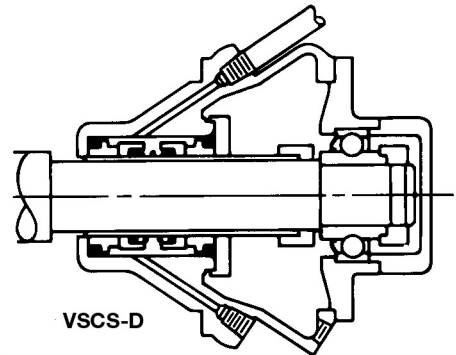

VSCS-D

BEARING MAINTENANCE

BEARING LUBRICATION SCHEDULE

Type of bearing	First lubrication, assembled pumps and replacement bearing frames	First lubrication, replacement bearings	Lubrication interval, pump, polyurea-based grease, operating hours
Grease-lubricated bearings	Not applicable, lubricated before shipment	Hand pack bearings before pressing on the shaft. After bearing frame assembly, follow relube instructions to lube bearings.	<ul style="list-style-type: none"> • 3600 hours, 2 pole • 7200 hours, 4 pole • 50% for severe conditions: dirty, wet and/or above 100°F (38°C) ambient • 50% for bearing frame temperature above 180°F (82°C) • 75% for lithium-based grease

REGREASE THE GREASE-LUBRICATED BEARINGS

It is important to lubricate pumps and motors that require regreasing with the proper grease. See the motor service instructions and nameplate for motor regreasing information. Pumps are to be regreased using the grease types listed below or approved equal. Always keep pump and motor properly lubricated.

NOTICE:

Make sure the grease container, the greasing device, and the fittings are clean. Failure to do so can result in impurities entering the bearing housing when you regrease the bearings.

1. With fully enclosed coupling guards, regrease pump while pump is running.
 - a. With old style open ended guards, stop pump, re-grease, and hand turn shaft before re-starting.
2. Wipe dirt from the grease fittings before greasing.
3. Fill both of the grease cavities through the fittings with the recommended grease. Stop when grease leaks out at shaft.
4. If needed, stop pump and wipe off excess grease.
5. Restart pump.

The bearing temperature usually rises after you regrease due to excess supply of grease. Temperatures return to normal in about two to four operating hours as the pump runs and purges the excess grease from the bearings. Maximum normal bearing housing temperature for polyurea-based grease is 225°F (107°C) and for lithium-based grease 180°F (82°C).

LUBRICATING GREASE REQUIREMENTS

NOTICE:

- Never mix grease of different consistencies (NLGI 1 or 3 with NLGI 2) or with different thickeners. For example, never mix lithium-based grease with a polyurea-based grease. This can result in decreased performance.
- Remove the bearings and old grease if you need to change the grease type or consistency. Failure to do so can result in equipment damage or decreased performance.

SPECIFICATIONS - GREASE TYPES

Polyurea-based greases	Lithium-based greases, NLGI 2
Pumps built on or after Dec 1, 2014 use Polyurea-based greases. See date code label and lubrication label on pump or bearing frame indicating polyurea-base grease	Pumps built before Dec 1, 2014 were built with Lithium-based greases, NLGI 2, and do not have lubrication label on pump or bearing frame indicating pump grease type
ExxonMobil Polyrex™ EM	Shell Gadus® S2 V100 2 (was Alvania® RL 2)
Chevron SRI NLGI 2	Chevron Multifak® EP 2
Shell Gadus® S5 T100 2	ExxonMobil Unirex™ N2

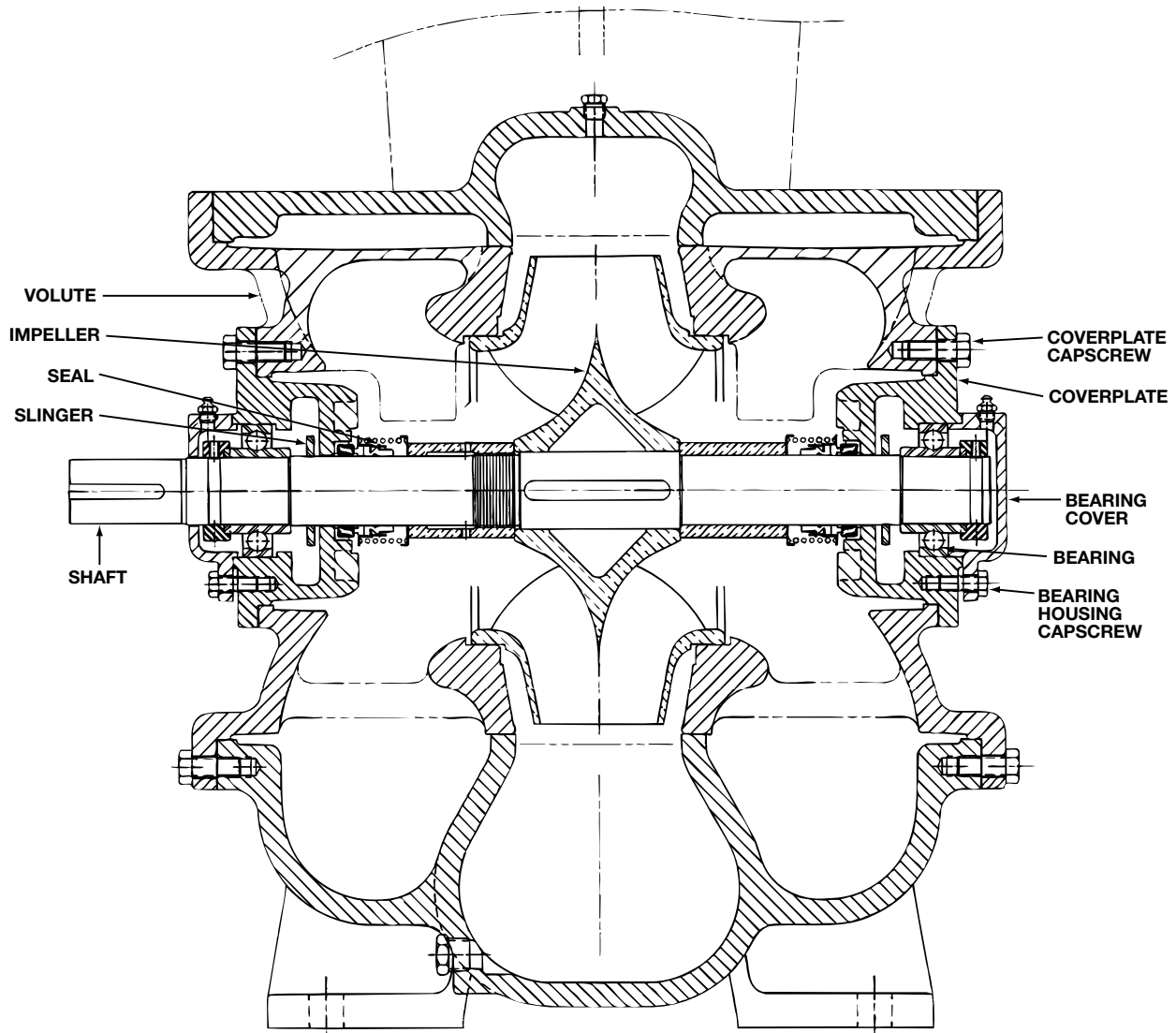

STANDARD SEAL CONFIGURATION

SERVICE INSTRUCTIONS

(Follow these first three steps for all VSC(S) pumps, then proceed to the pump size and model that corresponds to the size and model on the pump nameplate).

⚠ WARNING: Unexpected Startup Hazard
 Disconnect and lockout power before servicing. Failure to follow these instructions could result in serious personal injury or death, or property damage.

1. Close valves on suction and discharge sides of pump. If no valves have been installed, it will be necessary to drain the system.
2. Remove the coupler guard. Refer to section titled "Hex Coupler Guard Removal/Installation."

⚠ CAUTION: Extreme Temperature Hazard
 Allow pump temperatures to reach acceptable levels before proceeding. Open drain valve, do not proceed until liquid stops coming out of drain valve. If liquid does not stop flowing from drain valve, isolation valves are not sealing and should be repaired before proceeding. After liquid stops flowing from drain valve, leave valve open and continue. Remove the drain plug located on the bottom of the pump housing. Do not reinstall plug or close drain valve until reassembly is completed. Failure to follow these instructions could result in property damage and/or moderate personal injury.

3. Loosen the capscrews which secure the coupler flanges to the coupler hubs. Remove the coupler flanges and sleeve by compressing the flanges and pulling out from beneath the hubs or by loosening the allen set screws and sliding the hubs back on the shafts. Remove the coupler hub from the pump shaft.

INSTRUCTIONS FOR CHANGING DIRECTION OF ROTATION FOR VSC AND VSCS PUMPS

1. Remove coupler guard and coupler.
2. Remove both bearing caps and bearing lock nuts.
3. Remove both bearing housings together with bearing.
4. Remove outboard cover plate.
5. Remove shaft and impeller assembly.
6. Remove impeller nut and pull (press fitted) impeller from shaft. Observe direction that vane tips are pointing. Turn impeller end for end (180°) and press back onto shaft. The vane tips should be pointing in the opposite direction.
7. Remove volute from base. Remove inboard cover plate from volute.*
8. Reassemble cover plate, which was removed from outboard side, by placing on *same* side of volute. Turn volute end for end (180°) and mount back on base. The cover plate that was located on the outboard side of the pump, should now be on the inboard (motor) side of the pump.
9. Insert shaft assembly, with reversed impeller, back into pump casing and reassemble second cover plate (now outboard) to volute.
10. Reassemble seals, bearing housings, bearing and bearing caps. (Bearings and housings are identical side to side.)
11. Reassemble coupler and reattach guard.

In summary, the impeller, volute and cover plates should all have been reversed end for end. The orientation of the remaining parts should not have changed.

*It is important to remember that in the order to keep the water passages open, the cover plates must be reassembled to the same side of the volute from which they were removed. In effect, they should be rotated *along with* the volute. In fact, the inboard cover plate does not need to be removed, if the complete pump end is reassembled *before* being mounted on the base.

SERVICE INSTRUCTIONS FOR PUMPS WITH A STANDARD MECHANICAL SEAL (VSC-VSCS)

TO REPLACE THE SEALS:

4. Remove the bearing cover capscrews. To release the bearing cam lock, loosen the allen set screw and tap the cam lock counter-clockwise with a drift pin.
5. Remove two capscrews and loosen the remaining capscrews that hold the bearing housing to the volute coverplate.



WARNING: Excessive Pressure Hazard

Make certain internal pressure is relieved before continuing. Failure to follow these instructions could result in serious personal injury or death, or property damage.

Remove the bearing housing by placing two capscrews in the jackscrew holes provided.

6. Remove the bearing from the bearing housing by gently tapping the bearing's inner race. **NOTE:** If the water slinger has fallen into the bearing housing, be sure to remove and replace with the one provided (see Figure 1). Take care to avoid damage to the ceramic seal insert.
7. Remove the ceramic insert from housing by tapping from the rear.
8. Using 2 screwdrivers, pull the rotating seal assembly from the pump shaft (see Figure 2). Clean and inspect the shaft and bearing housing for damage, replace if required.

IMPORTANT: When working on the seal on the non-coupler end, it is necessary to force the pump shaft back from the coupler end as far as possible and to hold it in this position while installing and locking the bearing to the shaft. Also, when replacing both seals, the seal on the non-coupler end of the pump should be installed first.

9. Lubricate the seal assemblies and insert cups with soapy water, and then place the rotating seal assemblies on the shaft and the ceramic inserts and cups into each of the bearing housings, make certain inserts bottom against bores. Install the bearing housing gaskets and the bearing housings on the pump.
10. Slide the water slingers on the shaft and over the shoulder so as not to interfere with the bearings. Clean and re-grease bearings and insert into bearing housings. Push the pump shaft back from the motor end as far as possible, using a lever if necessary. Hold the shaft in this position.

11. Replace drain plug.
12. Install coupler and align, following the instructions located in the "Coupler Alignment" section.
13. Install coupler guard. Refer to separate instructions titled "Hex Coupler Guard Removal/Installation."
14. Open isolation valves and check pump for leaks. If not leaking, return pump to service.



FIGURE 1



FIGURE 2

SERVICE INSTRUCTIONS FOR PUMPS WITH A SINGLE FLUSH MECHANICAL SEAL (VSC-S, VSCS-S)

(See special instructions for pumps 10 x 12 x 17, 12 x 14 x 12¹/₂, 12 x 14 x 17¹/₂ and 8 x 10 x 17)

TO REPLACE THE SEALS OR SHAFT SLEEVES:

4. Remove bearing cover and release bearing cam lock.
5. Remove bearing housing capscrews. Pull housing and bearing from the pump shaft using capscrews in jack-screw holes.



WARNING: Excessive Pressure Hazard

Make certain internal pressure is relieved before continuing. Failure to follow these instructions could result in serious personal injury or death, or property damage.

6. Remove flushing tube and capscrews from seal housing.
7. Remove outer two set screws in shaft sleeve drive collar. Loosen two inner set screws one turn.
8. Remove the drive collar, seal housing, rotating seal assembly and sleeve.
9. To assemble the pump, clean shaft sleeve and pump shaft. Replace shaft sleeve if pitted or scored. If replacing the seal, remove shaft O-ring and replace (included in seal kit).
10. Lubricate O-ring on stationary seal seat (carbon) with silicone grease or soapy water. DO NOT USE PETROLEUM LUBRICANT! Position in seal housing.
11. Place shaft sleeve in drive collar and tighten the two dog point set screws in holes provided.
12. Set shaft sleeve and drive collar assembly on end and place assembly aid spacer around the shaft sleeve. Position against drive collar.
13. Place seal housing with carbon over the end of the sleeve against assembly aid spacer.

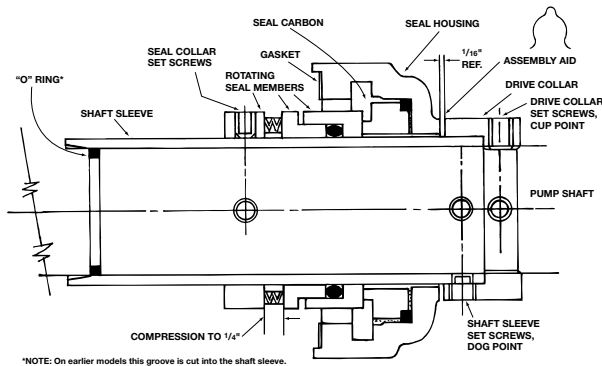

14. Lubricate O-ring in rotating seal assembly with silicone grease or soapy water. DO NOT USE PETROLEUM LUBRICANT! Slip rotating seal assembly on the end of the sleeve and place against carbon.
15. Compress rotating seal assembly to a 1/4" space between the seal parts that house the compression springs. Tighten set screws.
16. Apply anti-seize compound only to the area of the shaft that will be under the sleeve. Place seal housing gasket in position and slide complete assembly over pump shaft.

IMPORTANT! When working on the seal on the non-coupler end, it is necessary to force the pump shaft back from the coupler end as far as possible and to hold it in this position while installing and locking the bearing to the shaft. Also, when replacing both seals, the seal on the non-coupler end of the pump should be installed first.

17. Install the bearing housings. Clean and regrease the bearings and insert into bearing housings. Push the pump shaft back from the motor end as far as possible, using a lever if necessary. Hold the shaft in this position. On the outboard bearing tap inner race until it is properly positioned against the shaft shoulder. Install and lock the cam lock into position. If the shaft and bearing are properly positioned, the cam lock set screw will fall in the center of the shaft undercut. Release the shaft. Install the outboard bearing cap. Install the inboard bearing by tapping the inner race until it contacts the shaft shoulder, lock the bearing in place with the cam lock. Install the inboard bearing cap.
18. Push on the drive collar until the seal housing is against the stuffing box bracket, bolt into place.
19. Tighten down collar set screws in undercut of shaft. Remove assembly aid spacer and connect flush tubing to seal housing.
20. Replace drain plug.
21. Install coupler and align, following the instructions located in the section titled "Coupler Alignment."
22. Install coupler guard. Refer to separate instructions titled "Hex Coupler Guard Removal/Installation."
23. Open isolation valves and check pump for leaks. If not leaking, return pump to service.

SERVICE INSTRUCTIONS FOR PUMPS WITH A DOUBLE FLUSH MECHANICAL SEAL (VSC-D, VSCS-D)

(See special instructions for pumps 10 x 12 x 17, 12 x 14 x 12¹/₂, 12 x 14 x 17¹/₂ and 8 x 10 x 17)

TO REPLACE THE SEAL OR SHAFT SLEEVE:

4. Remove bearing cover and release bearing cam lock.
5. Remove bearing housing capscrews. Pull housing and bearing from shaft using capscrews in jackscrew holes.
6. Remove flush tube and capscrews from seal housing.
7. Remove outer two screws in shaft sleeve drive collar.



WARNING: Excessive Pressure Hazard

Make certain internal pressure is relieved before continuing. Failure to follow these instructions could result in serious personal injury or death, or property damage.

8. Remove stuffing box bracket capscrews and pull entire stuffing box assembly from the volute coverplate.
9. Remove the seal cap and seal assembly from the stuffing box.
10. If replacing the shaft sleeve, remove the sleeve and replace. Inspect all parts to be re-used and replace if damaged.
11. Lubricate stationary O-ring with silicone grease or soapy water. DO NOT USE PETROLEUM LUBRICANT! Insert O-ring toward impeller. Place one seal carbon into the bottom of the stuffing box and carefully install in position.
12. Lubricate the O-rings of the rotating seal member and position on sleeve against the seal carbon.

13. Install the second seal carbon. Lubricate and insert second stationary O-ring toward cap. Replace seal cap.
14. Apply anti-seize compound only to the shaft that will be under the sleeve.
15. Place the stuffing box gasket onto the bracket and install assembly into the coverplate. Position sleeve drive collar outer holes over undercut in shaft and tighten set screws. Install the bearing housings.

IMPORTANT! When working on the seal on the non-coupler end, it is necessary to force the pump shaft back from the coupler end as far as possible and to hold it in this position while installing and locking the bearing to the shaft. Also, when replacing both seals, the seal on the non-coupler end of the pump should be installed first.

16. Clean and regrease the bearings and insert into bearing housings. Push the pump shaft back from the motor end as far as possible, using a lever if necessary. Hold the shaft in this position. On the outboard bearing tap inner race until it

is properly positioned against the shaft shoulder. Install and lock the cam lock into position. If the shaft and bearing are properly positioned, the cam lock set screw will fall in the center of the shaft undercut. Release the shaft. Install the outboard bearing cap. Install the inboard bearing by tapping the inner race until it contacts the shaft shoulder, lock the bearing in place with the cam lock. Install the inboard bearing cap.

17. Replace drain plug.
18. Install coupler and align per instructions located in the section titled "Coupler Alignment."
19. Install coupler guard. Refer to separate instructions titled "Hex Coupler Guard Removal/Installation."
20. Open isolation valves and check pumps for leaks. If not leaking, return pump to service.

NOTE: Flushing pressure must be the suction pressure on the pump plus 10 PSI.

SPECIAL INSTRUCTIONS FOR PUMPS (VSCS, VSC-S & VSCS-D)

10 x 12 x 17, 12 x 14 x 12¹/₂ and 12 x 14 x 17¹/₂

TO REPLACE THE SEAL OR SHAFT SLEEVE:



WARNING: Excessive Pressure Hazard

Make certain internal pressure is relieved before continuing. Failure to follow these instructions could result in serious personal injury or death, or property damage.

4. Remove flush tube and tube fitting from seal housing inside bearing bracket.
5. Remove bearing bracket capscrews and bearing cover capscrews inside the bracket.
6. Remove bearing bracket using capscrews in jackscrew holes. **DO NOT PULL BEARING COVER.**
7. Remove bearing locknut by straightening tab of lockwasher from notch in locknut and turning locknut counterclockwise.
8. Remove lockwasher and pull bearing from shaft.
9. Remove retainer ring from shaft, except on 12 x 14 x 17¹/₂.
10. Now remove bearing cover.
11. Remove capscrews from seal housing. Remove outer two set screws from shaft sleeve drive collar and loosen two inner set screws one turn.
12. Remove the sleeve and seal assembly from the shaft by pulling on the seal housing.
13. To assemble the pump, clean shaft sleeve and pump shaft. Replace shaft sleeve if pitted or scored. If replacing the seal, remove shaft O-ring and replace (included in seal kit).

NOTE: If installing -D seals refer to steps 10-12 on -D instructions then skip to 17.

14. Lubricate O-ring on stationary seal seat (carbon) with silicone grease or soapy water. **DO NOT USE PETROLEUM LUBRICANT!** Position in seal housing. Place shaft sleeve in drive collar and tighten the two dog point set screws in holes provided. Set shaft sleeve and drive collar assembly on end and place assembly aid spacer around shaft sleeve. Position against drive collar.
15. Place seal housing with carbon over the end of the sleeve against assembly aid spacer.
16. Lubricate O-ring in rotating seal assembly with silicone grease or soapy water. **DO NOT USE PETROLEUM LUBRICANT!** Slip rotating seal assembly on the end of the sleeve and place against carbon.

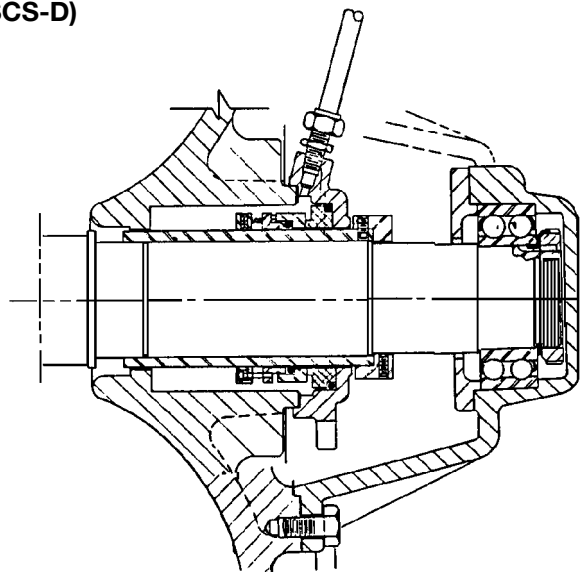

17. Compress rotating seal assembly to a 1/4" space between the seal parts that house the compression springs. Tighten set screws.
18. Apply anti-seize compound only to the area of the shaft that will be under the sleeve. Place seal housing gasket in position and slide complete assembly over pump shaft.
19. Slide bearing cover on shaft. Replace snap rings (if used) clean and regrease bearings. Place on shaft. Lock in place with lockwasher and locknut. Install bearing bracket and bearing cover.
20. Push on the drive collar until the seal housing is against the coverplate. Bolt into place.
21. Tighten down collar set screws in undercut of shaft. Remove assembly aid spacer and connect flush tubing to seal housing.
22. Replace drain plug.
23. Install coupler and align, following the instructions located in the section titled "Coupler Alignment."
24. Install coupler guard. Refer to separate instructions titled "Hex Coupler Guard Removal/Installation."
25. Open isolation valves and check pump for leaks. If not leaking, return pump to service.

SPECIAL INSTRUCTIONS FOR PUMPS (VSCS-S & VSCS-D) 8 x 10 x 17

TO REPLACE THE SEAL OR SHAFT SLEEVE:

4. Remove bearing cover and release bearing cam lock.
5. Remove bearing housing capscrews. Pull housing and bearing from pump shaft using capscrews in jackscrew holes.



WARNING: Excessive Pressure Hazard

Make certain internal pressure is relieved before continuing. Failure to follow these instructions could result in serious personal injury or death, or property damage.

6. Remove seal plate capscrews and flush tube.
 7. Remove outer two screws in shaft sleeve drive collar and loosen two inner set screws one turn.
 8. Pull entire sleeve and seal assembly from shaft.
 9. To assemble the pump, clean shaft sleeve and pump shaft. Replacer shaft sleeve if pitted or scored. If replacing the seal, remove shaft O-ring and replace (included in seal kit).
- NOTE:** If installing -D seals refer to steps 10-12 on -D instructions, then skip to step 15.
10. Lubricate O-ring on stationary seal seat (carbon) with silicone grease or soapy water. **DO NOT USE PETROLEUM LUBRICANT!** Position in seal housing.
 11. Place shaft sleeve in drive collar and tighten the two dog point set screws in holes provided.
 12. Set shaft sleeve and drive collar assembly on end and place assembly aid spacer around shaft sleeve. Position against drive collar.
 13. Place seal housing with carbon over the end of the sleeve against assembly aid spacer.
 14. Lubricate O-ring in rotating seal assembly with silicone grease or soapy water. **DO NOT USE PETROLEUM LUBRICANT!** Slip rotating seal assembly on the end of the sleeve and place against carbon.

15. Compress rotating seal assembly to a 1/4" space between the seal parts that house the compression springs. Tighten set screws.
16. Apply anti-seize compound only to the area of the shaft that will be under the sleeve. Place seal housing gasket in position and slide complete assembly over pump shaft.

IMPORTANT! When working on the seal on the non-coupler end, it is necessary to force the pump shaft back from the coupler end as far as possible and to hold it in this position while installing and locking the bearing to the shaft. Also, when replacing both seals, the seal on the non-coupler end of the pump should be installed first.

17. Install the bearing housings. Clean and regrease the bearings and insert into bearing housings. Push the pump shaft back from the motor end as far as possible, using a lever if necessary. Hold the shaft in this position. On the outboard bearing tap inner race until it is properly positioned against the shaft shoulder. Install and lock the cam lock into position. If the shaft and bearing are properly positioned, the cam lock set screw will fall in the center of the shaft undercut. Release the shaft. Install the outboard bearing cap. Install the inboard bearing by tapping the inner race until it contacts the shaft shoulder, lock the bearing in place with the cam lock. Install the inboard bearing cap.
18. Push on the drive collar until the seal housing is against the coverplate, bolt into place.
19. Tighten down collar set screws in undercut of shaft. Remove assembly aid spacer and connect flush tubing to seal housing.
20. Replace drain plug.
21. Install coupler and align, following the instructions located in the section titled "Coupler Alignment."
22. Install coupler guard. Refer to separate instructions titled "Hex Coupler Guard Removal/Installation."
23. Open isolation valves and check pump for leaks. If not leaking, return pump to service.

SERVICE INSTRUCTIONS FOR PUMPS WITH FLUSH PACKING (VSC-PF, VSCS-PF)

(See special instructions for pumps 10 x 12 x 17, 12 x 14 x 12¹/₂ and 8 x 10 x 17)

TO REPLACE THE PACKING OR SHAFT SLEEVE:

4. Remove bearing cover and release cam lock.
5. Remove bearing housing capscrews. Pull housing and bearing from pump shaft using capscrews in jackscrew holes.



WARNING: Excessive Pressure Hazard

Make certain internal pressure is relieved before continuing. Failure to follow these instructions could result in serious personal injury or death, or property damage.

6. Remove flush tube and capscrews from the stuffing box.
7. Remove packing gland and packing rings from stuffing box.
8. Loosen outer two set screws in shaft sleeve drive collar and pull entire shaft sleeve with stuffing box from the pump shaft.
9. To assemble, clean out stuffing box thoroughly and assemble to volute coverplate.

10. Apply anti-seize compound only to the area of the shaft that will be under the sleeve. Install shaft sleeve on shaft. Position sleeve drive collar outer holes over undercut in shaft and tighten set screws. If sleeve is pitted or scored, the sleeve should be replaced.
11. Insert two packing rings into the stuffing box, staggering the joints 90°.
12. Install the lantern ring and then the other two packing rings, staggering them 90°.
13. Install, but do not tighten packing gland.

IMPORTANT! When working on the packing on the non-coupler end, it is necessary to force the pump shaft back from the coupler end as far as possible and to hold it in this position while installing and locking the bearing to the shaft. Also, when replacing both packings, the packing on the non-coupler end of the pump should be installed first.

14. Install the bearing housings. Clean and regrease the bearings and insert into bearing housings. Push the pump shaft back from the motor end as far as possible, using a lever if necessary. Hold the shaft in this position. On the outboard bearing tap inner race until it is properly positioned against the shaft shoulder. Install and lock the cam lock into position. If the shaft and bearing are properly positioned, the cam lock set screw will fall in the center of the shaft undercut. Release the shaft. Install the outboard bearing cap. Install the inboard bearing by tapping the inner race until it contacts the shaft shoulder, lock the bearing in place with the cam lock. Install the inboard bearing cap.
15. Connect flush tubing to seal housing.
16. Replace drain plug.
17. Install coupler and align, following instructions located in the section titled "Coupler Alignment."
18. Install coupler guard. Refer to separate instructions titled "Hex Coupler Guard Removal/Installation."
19. Open isolation valves and check pumps for leaks. If not leaking, return pump to service using the -PF Start-up Instructions.

SPECIAL INSTRUCTIONS FOR PUMPS (VSCS-PF) 10 x 12 x 17 and 12 x 14 x 12^{1/2}

TO REPLACE THE PACKING:



WARNING: Excessive Pressure Hazard

Make certain internal pressure is relieved before continuing. Failure to follow these instructions could result in serious personal injury or death, or property damage.

4. Remove flush tube and tube fitting from inside bearing bracket.
5. Remove bearing bracket capscrews and bearing cover capscrews inside the bracket.
6. Remove bearing bracket using capscrews in jackscrew holes. **DO NOT PULL BEARING COVER.**
7. Remove bearing locknut by straightening tab of lockwasher from notch in locknut and turning locknut counterclockwise.
8. Remove lockwasher and pull bearing from shaft.
9. Remove retainer ring from shaft.
10. Remove bearing cover.
11. Remove packing gland capscrews and packing gland.
12. Using a packing puller, remove packing rings and lantern ring.
13. Remove and replace the shaft sleeve. Apply anti-seize compound only to the area of the shaft that will be under the sleeve. Install new sleeve on shaft. Position sleeve drive collar outer holes over undercut in shaft and tighten set screws.
14. Insert two packing rings, staggering the joints 90°.
15. Install the lantern ring and then the other two packing rings, staggering them 90°.
16. Install, but do not tighten the packing gland.
17. Slide bearing cover on shaft. Replace snap rings (if used). Clean and regrease bearings. Place on shaft, lock in place, with lockwasher and locknut. Install bearing bracket and bearing cover.
18. Replace drain plug.
19. Install coupler and align, following the instructions located in the section titled "Coupler Alignment."
20. Install coupler guard. Refer to separate instructions titled "Hex Coupler Guard Removal/Installation."
21. Open isolation valves and check pump for leaks. If not leaking, return pump to service, using the -PF Start-up Instructions.

SPECIAL INSTRUCTIONS FOR PUMPS (VSCS-PF) 8 x 10 x 17

TO REPLACE THE PACKING:



WARNING: Excessive Pressure Hazard

Make certain internal pressure is relieved before continuing. Failure to follow these instructions could result in serious personal injury or death, or property damage.

4. Remove flush tube and tube fitting from inside bearing bracket.
 5. Remove bearing cover and release bearing cam lock.
 6. Remove capscrews that hold the bearing housing to the volute coverplate and release, using capscrews in jackscrew holes.
 7. Pull housing and bearing from shaft.
 8. Remove packing gland capscrews and packing gland.
 9. Using a packing puller, remove packing rings and lantern ring.
 10. Remove and replace the shaft sleeve. Apply anti-seize compound only to the area of the shaft that will be under the sleeve. Install new sleeve on shaft. Position sleeve drive collar outer holes over undercut in shaft and tighten set screws.
 11. Insert two packing rings, staggering the joints 90°.
 12. Install the lantern ring and then the other two packing rings, staggering them 90°.
 13. Install, but do not tighten the packing gland.
- IMPORTANT!** When working on the packing on the non-coupler end, it is necessary to force the pump shaft back from the coupler end as far as possible and to hold it in this position while installing and locking the bearing to the shaft. Also, when replacing both packings, the packing on the non-coupler end of the pump should be installed first.

14. Install the bearing housings. Clean and regrease the bearings and insert into bearing housings. Push the pump shaft back from the motor end as far as possible, using a lever if necessary. Hold the shaft in this position. On the outboard bearing tap inner race until it is properly positioned against the shaft shoulder. Install and lock the cam lock into position. If the shaft and bearing are properly positioned, the cam lock set screw will fall in the center of the shaft undercut. Release the shaft. Install the outboard bearing cap. Install the inboard bearing by tapping the inner race until it contacts the shaft shoulder, lock the bearing in place with the cam lock. Install the inboard bearing cap.
15. Connect flush tubing to seal housing.
16. Replace drain plug.
17. Install coupler and align, following the instructions located in the section titled "Coupler Alignment."
18. Install coupler guard. Refer to separate instructions titled "Hex Coupler Guard Removal/Installation."
19. Open isolation valves and check pump for leaks. If not leaking, return pump to service, using the -PF Start-up Instructions.

-PF START-UP INSTRUCTIONS

Prior to start-up, back off packing glands or screws until glands are loose. Re-tighten with fingers until glands are just snug against the first packing ring. WHEN PUMP IS STARTED, WATER MAY RUN FREELY FROM PACKING. This is normal and should be allowed to continue for a period of time before further tightening the glands. Tighten the gland bolts uniformly, one flat at a time.

An adequate leakage rate is NOT ONE SINGLE VALVE FOR ALL pumps and installations, but is the amount required to provide adequate cooling and lubrication. The required leakage will be largely influenced by operating pressures, fluid temperature, shaft speed, etc.

For fluid temperatures in the range of 32° to 190°F average leakage rates of 60 to 80 drops per minute are recommended. However, each individual pump and installation will have unique operating conditions that will result in broadly variable leakage rate requirements.

At fluid operating temperatures near the upper limit of 190°F, the maximum temperature rise of the leakage is particularly important. A packed pump should never operate with steam forming at the gland. This necessarily limits the temperature rise to a maximum of about 20°F. If the formation of steam persists at higher leakage rates, cooling water must be provided by means of an external supply, or a heat exchanger used to cool the by-pass flush.

HEX COUPLER GUARD REMOVAL/INSTALLATION



WARNING: Unexpected Startup Hazard

Disconnect and lockout power before servicing. Failure to follow these instructions could result in serious personal injury or death, or property damage.

NOTE: Do not spread the inner and outer guards more than necessary for guard removal or installation. Over spreading the guards may alter their fit and appearance.

REMOVAL

1. Remove the two capscrews that hold the outer (motor side) coupler guard to the support bracket(s).
2. Spread the outer guard and pull it off the inner guard.
3. Remove the capscrew that holds the inner guard to the support bracket.
4. Spread the inner guard and pull it over the coupler.

INSTALLATION

1. Check coupler alignment before proceeding. Correct if necessary.
2. Spread the inner guard and place it over the coupler.

3. With the inner guard straddling the support bracket, install a capscrew through the hole (or slot) in the support bracket and guard located closest to the pump. Do not tighten the capscrew.
4. Spread the outer guard and place it over the inner guard.
5. Install the outer guard capscrews by following the step stated below which pertains to your particular pump:
 - a) *For pumps with a motor saddle support bracket:* Ensure the outer guard is straddling the support arm, and install but do not tighten the two remaining capscrews.
 - b) *For pumps without a motor saddle support bracket:* Insert the spacer washer between the holes located closest to the motor in the outer guard, and install but do not tighten the two remaining capscrews.
6. Position the outer guard so it is centered around the shaft, and so that there is less than a 1/4" of the motor shaft exposed. On guards that utilize a slotted support bracket, the inner guard will have to be positioned so there is only a 1/4" of the pump shaft exposed.
7. Holding the guard in this position, tighten the three capscrews.

HEX GUARD EXPLODED VIEW FOR TYPICAL VSC/VSCS PUMP INSTALLATION

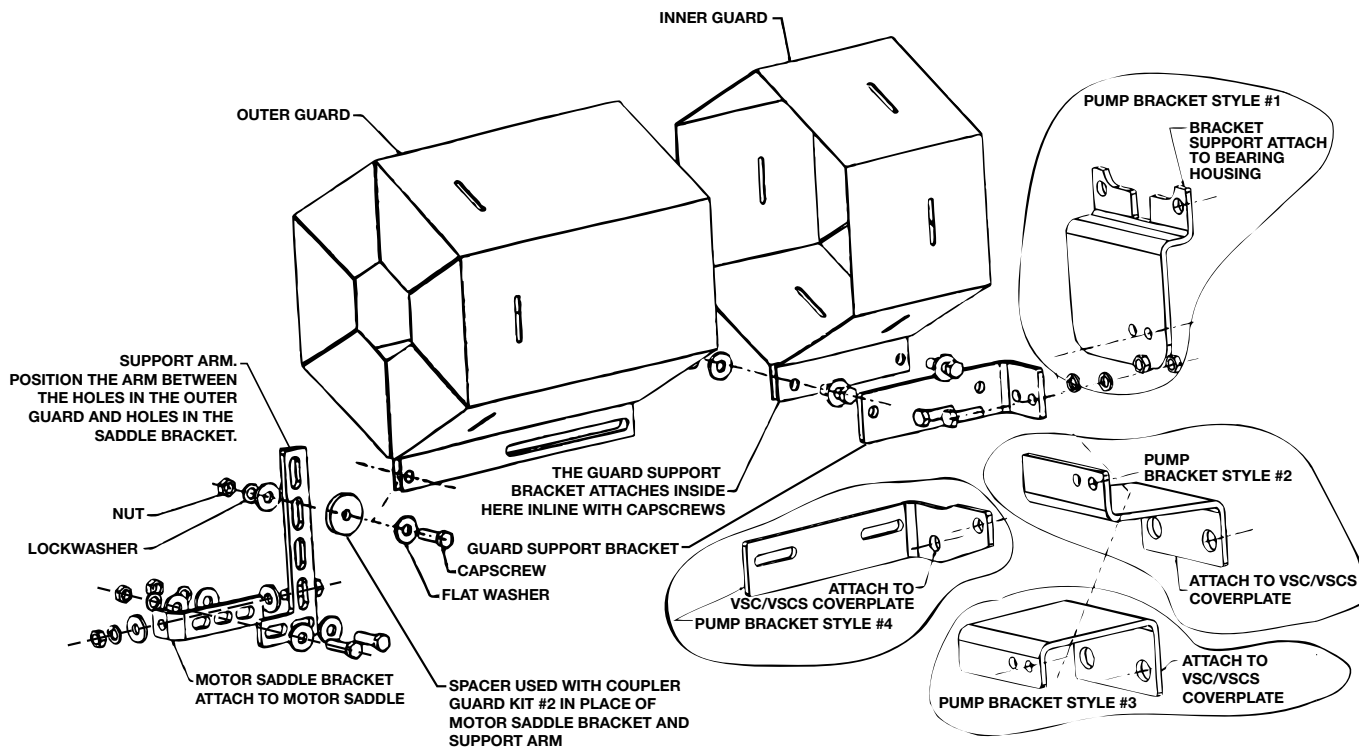

CAPSCREW TYPE	HEAD MARKING	CAPSCREW TORQUE (FOOT-POUND)								
		CAPSCREW DIAMETER								
		1/4	5/16	3/8	7/16	1/2	5/8	3/4	7/8	1
SAE Grade 2		6	13	25	38	60	120	190	210	300
Brass Stainless Steel		4	10	17	27	42	83	130	200	300
SAE Grade 5		10	20	35	60	90	180	325	525	800

DEALER SERVICING

If trouble occurs that cannot be rectified contact your local B&G representative, He will need the following information in order to give you assistance.

1. Complete nameplate data of pump and motor.
2. Suction and discharge pipe pressure gauge readings.
3. Ampere draw of the motor.
4. A sketch of the pump hook-up and piping.

Xylem |'zīləm|

- 1) The tissue in plants that brings water upward from the roots;
- 2) a leading global water technology company.

We're a global team unified in a common purpose: creating advanced technology solutions to the world's water challenges. Developing new technologies that will improve the way water is used, conserved, and re-used in the future is central to our work. Our products and services move, treat, analyze, monitor and return water to the environment, in public utility, industrial, residential and commercial building services settings. Xylem also provides a leading portfolio of smart metering, network technologies and advanced analytics solutions for water, electric and gas utilities. In more than 150 countries, we have strong, long-standing relationships with customers who know us for our powerful combination of leading product brands and applications expertise with a strong focus on developing comprehensive, sustainable solutions.

For more information on how Xylem can help you, go to www.xylem.com



Xylem Inc.
8200 N. Austin Avenue
Morton Grove, Illinois 60053
Phone: (847) 966-3700
Fax: (847) 965-8379
www.xylem.com/bellgossett