

(H)12x8x21F - 9100 SERIES

May 2019

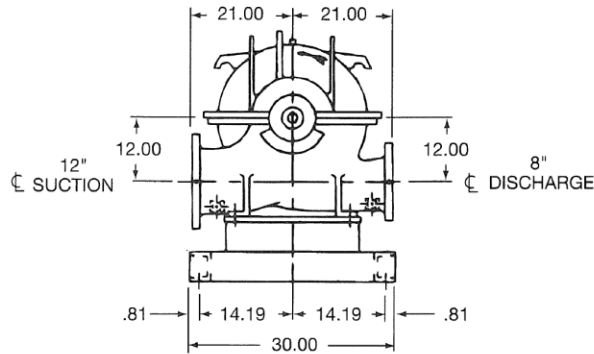

CCW ROTATION VIEWED FROM COUPLING END

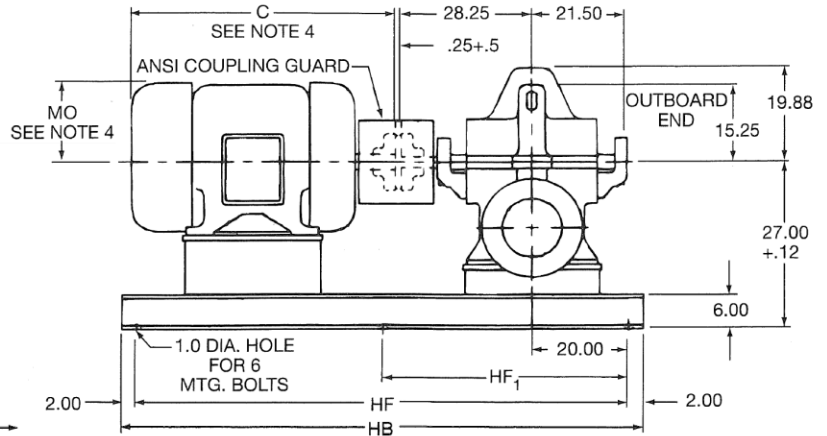
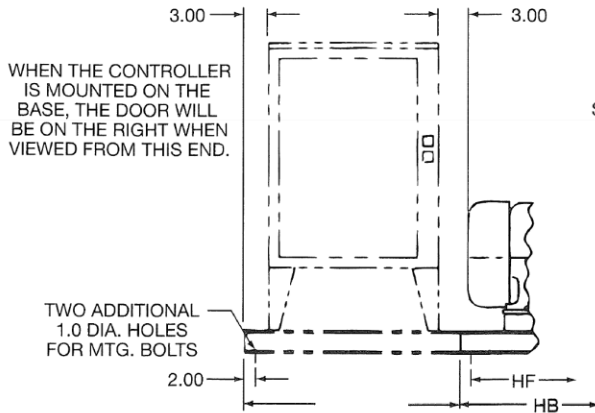
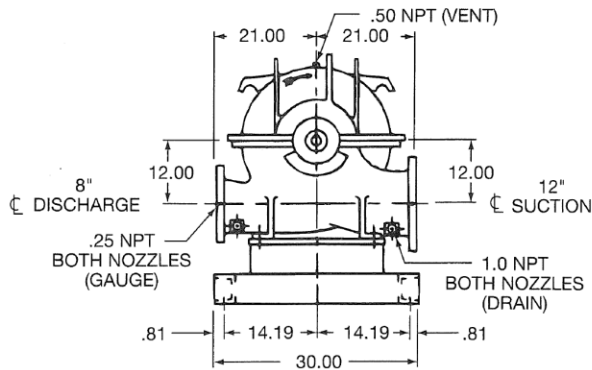

CW ROTATION VIEWED FROM COUPLING END

MOTOR FRAMES	C	HB	HF	HF ₁	MO
445TS	40.5	96.0	92.0	46.0	11.8
445T	44.3	96.0	92.0	46.0	11.8
447TS	44.0	96.0	92.0	46.0	11.8
447T	47.8	96.0	92.0	46.0	11.8
449TS	44.6	96.0	92.0	46.0	11.8
449T	48.5	96.0	92.0	46.0	11.8
503US	36.0	96.0	92.0	46.0	14.0
504US	41.8	96.0	92.0	46.0	14.0

NOTES

- All Dimensions are in inches.
- 125# suction and 250# discharge connections are ANSI B16.1 standard flanges. Holes in flanges straddle ϕ . (See Note 6)
- Baseplate setting (before piping), grouting procedures and final alignment must be in accordance with A-C Fire Pump Systems recommended procedures outlined in the Instruction Manual associated with this pump type.
- Motor dimensions are approximate for a given NEMA frame. Consult factory if space is limited.
- Both suction and discharge pipes must be supported independently near the pump to reduce strain on the pump casing. Also expansion joints, if used, must not exert force on casing.
- "H" high pressure pumps over 250 PSI working pressure will have 250# ANSI B16.1 flat faced suction and discharge flanges. Holes in flanges straddle ϕ .

NOT FOR CONSTRUCTION, INSTALLATION OR APPLICATION PURPOSES UNLESS CERTIFIED.									
CERTIFIED FOR:							APPROVAL		UL FM ULC
							<input type="checkbox"/> <input type="checkbox"/> <input type="checkbox"/>		
CUSTOMER ORDER NO:			IDENTIFICATION NO:			FLANGES			
PUMP DATA	SIZE	MODEL	CURVE NO.	GPM	HEAD (FT)	ROTATION	SUCTION	FLANGES	
MOTOR DATA	HP	RPM	VOLTS	PHASE	HERTZ	FRAME SIZE	ENCLOSURE		
SHOP ORDER:			CERTIFIED BY:			DATE			