

267 Carbon Steel High Pressure Repair Clamp

4" - 24" Pipe Sizes

Product Specifications

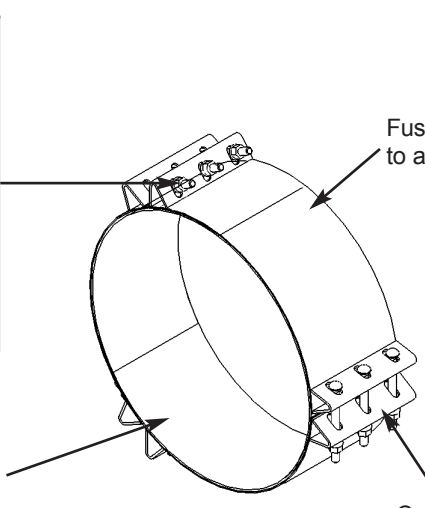

Bolts and Nuts:
3/4" (5/8" in 4" and 6" nominal) high strength, low alloy steel per AWWA C111 standards.
Option: Bolts in type 304 stainless steel and nuts in type 304 stainless steel with a fluoropolymer coating to prevent galling.

Washers:
Carbon steel per ASTM B633-78, electro-galvanized finish.

Gaskets with bridge plates:
Nitrile (Buna-N), compounded to resist natural gas, water, oil, acids, alkalies, most (aliphatic) hydrocarbon fluids and many chemicals.
Temperature Range: -20°F to +180°F.

Finish:
Fusion bonded Flexi-Coat epoxy, to an average of 12-mil thick.

Body and Lugs:
Carbon steel, per ASTM A283 C.

Features:

- Certified to NSF®/ANSI 61-G.
- No special tools required to install the clamp.
- 360° seal around the pipe for complete coverage.
- Flexi-coat epoxy coating for superior corrosion resistance.
- Lighter and easier to install than comparable cast iron repair sleeves.
- Higher pressure rating than standard band clamps for more pressure range coverage.

Clamp Number	Size	Working Pressure*
267	4" - 12" Nominal	Up to 300 PSI
267	14" - 24" Nominal	Up to 200 PSI

*The allowable working pressure of a pipe repair clamp decreases as pipe diameter increases (regardless of manufacturer). For a particular installation, the allowable working pressure will be determined by the size of pipe, type of pipe, type of clamp, type and extent of damage, service conditions, environmental conditions, and installation workmanship.

WARNING: Not to be used to couple pipe or repair full breaks.

Product Specifications

SPECIFICATION:

The high-pressure repair clamp shall have a body made of carbon steel per ASTM A283 C.

The gasket shall be NSF-61 approved, Nitrile (Buna N) compounded to resist: water, oil, alkalies, most (aliphatic) hydrocarbon fluids and other many chemicals. The gasket temperature rating shall be -20°F to +180°F.

The nuts and bolts shall be 3/4" (5/8" in 4"

and 6" nominal) high strength low alloy steel per AWWA C111 standards. The nuts shall be semi-finished hex head. The bolts shall be replaceable. The washers shall be carbon steel with electrogalvanized finish.

The clamp shall be coated with a fusion-bonded Flex Coat epoxy coated to an average of 12-mil thickness. The high-pressure clamp shall be NSF 61 listed.

The clamp shall be a Smith-Blair, Inc., 267 or approved equal.

Approved By
Name:
Title:
Date:

THESE PRODUCT SPECIFICATIONS WERE CORRECT AT TIME OF PUBLICATION.

MATERIAL SPECIFICATIONS ARE SUBJECT TO CHANGE WITHOUT NOTICE.

SEE CATALOG FOR MORE DETAILS. VISIT SMITH-BLAIR'S

WEBSITE AT WWW.SMITH-BLAIR.COM TO DOWNLOAD THE MOST CURRENT INFORMATION.



Ph: 870-773-5127 • Fax: 870-773-5212 • www.smith-blair.com

Toll-Free Numbers: Ph: 800-643-9705 • Fax: 800-648-6792

30 Globe Ave, Texarkana, AR 71854 • PO Box 5337, Texarkana, TX 75505